



NATIONAL POWER CORPORATION

**MinGen**

# **PHILIPPINE BIDDING DOCUMENTS**

**(Procurement of INFRASTRUCTURE PROJECTS)**

**FOR**

**INSTALLATION OF CYLINDRICAL TANK FOR  
HYDROTOR USED OIL**

**P.R. No.: MG-A5M22-165**

**Contracts Management Office  
Logistics Division**

**Sixth Edition**

**July 2020**

*Rev.1*

---

## TABLE OF CONTENTS

<b>GLOSSARY OF.....</b>	<b>4</b>
<b>TERMS, ABBREVIATIONS, AND ACRONYMS.....</b>	<b>4</b>
<b>SECTION I. INVITATION TO BID.....</b>	<b>7</b>
<b>SECTION II. INSTRUCTIONS TO BIDDERS.....</b>	<b>11</b>
1. Scope of Bid.....	12
2. Funding Information.....	12
3. Bidding Requirements.....	12
4. Corrupt, Fraudulent, Collusive, Coercive, and Obstructive Practices.....	13
5. Eligible Bidders.....	13
6. Origin of Associated Goods.....	13
7. Subcontracts.....	13
8. Pre-Bid Conference.....	14
9. Clarification and Amendment of Bidding Documents.....	14
10. Documents Comprising the Bid: Eligibility and Technical Components.....	14
11. Documents Comprising the Bid: Financial Component.....	15
12. Alternative Bids.....	15
13. Bid Prices.....	15
14. Bid and Payment Currencies.....	15
15. Bid Security.....	15
16. Sealing and Marking of Bids.....	16
17. Deadline for Submission of Bids.....	16
18. Opening and Preliminary Examination of Bids.....	16
19. Detailed Evaluation and Comparison of Bids.....	16
20. Post Qualification.....	17
21. Signing of the Contract.....	17
<b>SECTION III. BID DATA SHEET.....</b>	<b>18</b>
<b>SECTION IV. GENERAL CONDITIONS OF CONTRACT.....</b>	<b>22</b>
1. Scope of Contract.....	23
2. Sectional Completion of Works.....	23
3. Possession of Site.....	23
4. The Contractor's Obligations.....	23
5. Performance Security.....	24

6.	Site Investigation Reports.....	24
7.	Warranty .....	24
8.	Liability of the Contractor .....	24
9.	Termination for Other Causes.....	24
10.	Dayworks .....	25
11.	Program of Work .....	25
12.	Instructions, Inspections and Audits.....	25
13.	Advance Payment .....	25
14.	Progress Payments.....	26
15.	Operating and Maintenance Manuals .....	26
	<b>SECTION V. SPECIAL CONDITIONS OF CONTRACT .....</b>	<b>27</b>
	<b>SECTION VI. SPECIFICATIONS.....</b>	<b>29</b>
	<b>SECTION VII. DRAWINGS.....</b>	<b>60</b>
	<b>SECTION VIII. BILL OF QUANTITIES.....</b>	<b>66</b>
	<b>SECTION IX. CHECKLIST OF TECHNICAL AND FINANCIAL DOCUMENTS .....</b>	<b>70</b>
	<b>FORM OF BID SECURITY (SURETY BOND).....</b>	<b>77</b>
	<b>CONTRACTOR'S ORGANIZATIONAL CHART FOR THE CONTRACT .....</b>	<b>80</b>
	<b>JOINT VENTURE AGREEMENT .....</b>	<b>94</b>
	<b>BID FORM .....</b>	<b>96</b>
	<b>SUMMARY SHEETS OF MATERIALS PRICES, LABOR RATES AND EQUIPMENT RENTAL RATES .....</b>	<b>99</b>

# *Glossary of Terms, Abbreviations, and Acronyms*

**ABC** – Approved Budget for the Contract.

**ARCC** – Allowable Range of Contract Cost.

**BAC** – Bids and Awards Committee.

**Bid** – A signed offer or proposal to undertake a contract submitted by a bidder in response to and in consonance with the requirements of the bidding documents. Also referred to as *Proposal* and *Tender*. (2016 revised IRR, Section 5[c])

**Bidder** – Refers to a contractor, manufacturer, supplier, distributor and/or consultant who submits a bid in response to the requirements of the Bidding Documents. (2016 revised IRR, Section 5[d])

**Bidding Documents** – The documents issued by the Procuring Entity as the bases for bids, furnishing all information necessary for a prospective bidder to prepare a bid for the Goods, Infrastructure Projects, and/or Consulting Services required by the Procuring Entity. (2016 revised IRR, Section 5[e])

**BIR** – Bureau of Internal Revenue.

**BSP** – Bangko Sentral ng Pilipinas.

**CDA** – Cooperative Development Authority.

**Consulting Services** – Refer to services for Infrastructure Projects and other types of projects or activities of the GOP requiring adequate external technical and professional expertise that are beyond the capability and/or capacity of the GOP to undertake such as, but not limited to: (i) advisory and review services; (ii) pre-investment or feasibility studies; (iii) design; (iv) construction supervision; (v) management and related services; and (vi) other technical services or special studies. (2016 revised IRR, Section 5[i])

**Contract** – Refers to the agreement entered into between the Procuring Entity and the Supplier or Manufacturer or Distributor or Service Provider for procurement of Goods and Services; Contractor for Procurement of Infrastructure Projects; or Consultant or Consulting Firm for Procurement of Consulting Services; as the case may be, as recorded in the Contract Form signed by the parties, including all attachments and appendices thereto and all documents incorporated by reference therein.

**Contractor** – is a natural or juridical entity whose proposal was accepted by the Procuring Entity and to whom the Contract to execute the Work was awarded. Contractor as used in these Bidding Documents may likewise refer to a supplier, distributor, manufacturer, or consultant.

**CPI** – Consumer Price Index.



**DOLE** – Department of Labor and Employment.

**DTI** – Department of Trade and Industry.

**Foreign-funded Procurement or Foreign-Assisted Project** –Refers to procurement whose funding source is from a foreign government, foreign or international financing institution as specified in the Treaty or International or Executive Agreement. (2016 revised IRR, Section 5[b]).

**GFI** – Government Financial Institution.

**GOCC** –Government-owned and/or –controlled corporation.

**Goods** – Refer to all items, supplies, materials and general support services, except Consulting Services and Infrastructure Projects, which may be needed in the transaction of public businesses or in the pursuit of any government undertaking, project or activity, whether in the nature of equipment, furniture, stationery, materials for construction, or personal property of any kind, including non-personal or contractual services such as the repair and maintenance of equipment and furniture, as well as trucking, hauling, janitorial, security, and related or analogous services, as well as procurement of materials and supplies provided by the Procuring Entity for such services. The term “related” or “analogous services” shall include, but is not limited to, lease or purchase of office space, media advertisements, health maintenance services, and other services essential to the operation of the Procuring Entity. (2016 revised IRR, Section 5[r])

**GOP** – Government of the Philippines.

**Infrastructure Projects** – Include the construction, improvement, rehabilitation, demolition, repair, restoration or maintenance of roads and bridges, railways, airports, seaports, communication facilities, civil works components of information technology projects, irrigation, flood control and drainage, water supply, sanitation, sewerage and solid waste management systems, shore protection, energy/power and electrification facilities, national buildings, school buildings, hospital buildings, and other related construction projects of the government. Also referred to as *civil works or works*. (2016 revised IRR, Section 5[u])

**LGUs** – Local Government Units.

**NFCC** – Net Financial Contracting Capacity.

**NGA** – National Government Agency.

**PCAB** – Philippine Contractors Accreditation Board.

**PhilGEPS** - Philippine Government Electronic Procurement System.

**Procurement Project** – refers to a specific or identified procurement covering goods, infrastructure project or consulting services. A Procurement Project shall be described, detailed, and scheduled in the Project Procurement Management Plan prepared by the agency which shall be consolidated in the procuring entity's Annual Procurement Plan. (GPPB Circular No. 06-2019 dated 17 July 2019)

**PSA** – Philippine Statistics Authority.

**SEC** – Securities and Exchange Commission.

**SLCC** – Single Largest Completed Contract.

**UN** – United Nations.

## ***Section I. Invitation to Bid***

M

7



NATIONAL POWER CORPORATION

**MinGen**

## **Invitation to Bid for *Installation of Cylindrical Tank for Hydrotor Used Oil***

The *NATIONAL POWER CORPORATION-MINDANAO GENERATION*, through the approved Corporate Budget of NPC for CY 2022 intends to apply the sum of *One Million Three Hundred Thousand Pesos (PHP 1,300,000.00)* being the Approved Budget for the Contract (ABC) to payments under the contract for *Installation of Cylindrical Tank for Hydrotor Used Oil at NPC MinGen, Nangka, balo-I, Lanao del Norte (INFRA2022-AG5-052)*. Bids received in excess of the ABC shall be automatically rejected at bid opening.

1. The *NATIONAL POWER CORPORATION-MINDANAO GENERATION* now invites bids for the above Procurement Project. Completion of the Works is required *Eighty (80) calendar days*. Bidders should have completed a contract similar to the Project. The description of an eligible bidder is contained in the Bidding Documents, particularly, in Section II (Instructions to Bidders).
2. Bidding will be conducted through open competitive bidding procedures using non-discretionary "*pass/fail*" criterion as specified in the 2016 revised Implementing Rules and Regulations (IRR) of Republic Act (RA) No. 9184.
3. Interested bidders may obtain further information from *BAC Secretariat, NATIONAL POWER CORPORATION-MINDANAO GENERATION* and inspect the Bidding Documents at the address given below from *8:00 AM – 5:00 PM Monday to Friday*.
4. A complete set of Bidding Documents may be acquired by interested Bidders *August 3 - 23, 2022* from the given address and website(s) below and upon payment of the applicable fee for the Bidding Documents, pursuant to the latest Guidelines issued by the GPPB, in the amount of *Three Thousand Pesos (PHP3,000.00)*. The Procuring Entity shall allow the bidder to pay online and present its proof of payment for the fees *in person, by facsimile, or through electronic means. For those prospective bidders who wish to pay online, below are the details of the account:*

LandbankAccount name : NPC GENCO 5 COLLECTIONS FUND

LandbankAccount number : 0321-1689-14

It may also be downloaded free of charge from the website of the Philippine Government Electronic Procurement System (PhilGEPS) provided that Bidders shall

pay the applicable fee for the Bidding Documents not later than the submission of their bids.

5. The *NATIONAL POWER CORPORATION–MINDANAO GENERATION* will hold a Pre-Bid Conference on *August 11, 2022 at 9:00 AM* at *Bidding Room, NPC-Mindanao Generation Headquarters, Maria Cristina, Iligan City* and/or through videoconferencing/webcasting via *ZOOM*, which shall be open to prospective bidders. Interested online attendees are required to pre-register one (1) day before the scheduled pre-bidding conference. For pre-registration, contact tel. no. (063)-222-3459 or email [logistics\\_afd\\_mingen@napocor.gov.ph](mailto:logistics_afd_mingen@napocor.gov.ph).
6. Bids must be duly received by the BAC Secretariat through manual submission at the office address as indicated below, on or before *August 23, 2022 at 9:30 AM*. Late bids shall not be accepted.
7. All bids must be accompanied by a bid security in any of the acceptable forms and in the amount stated in **ITB** Clause 15.
8. Bid opening shall be on *August 23, 2022 at 9:30 AM* at the *Bidding Room, NPC-Mindanao Generation Headquarters, Maria Cristina, Iligan City*. Bids will be opened in the presence of the bidders' representatives who choose to attend the activity.
9. *This project requires submission of at least:*
  - ***Certificate of Site Inspection***
10. The *NATIONAL POWER CORPORATION– MINDANAO GENERATION* reserves the right to reject any and all bids, declare a failure of bidding, or not award the contract at any time prior to contract award in accordance with Sections 35.6 and 41 of the 2016 revised Implementing Rules and Regulations (IRR) of RA No. 9184, without thereby incurring any liability to the affected bidder or bidders.
11. For further information, please refer to:

***BAC Secretariat***  
*Contracts Management Office*  
*Logistics Division*  
*Mindanao Generation Headquarters*  
*National Power Corporation*  
*Maria Cristina, Iligan City*  
[logistics\\_afd\\_mingen@napocor.gov.ph](mailto:logistics_afd_mingen@napocor.gov.ph)  
*Tel. No.: (063)222-3459*  
*Fax No.: (063)223-8355/(063)223-4604*  
[www.napocor.gov.ph](http://www.napocor.gov.ph)

12. You may visit the following websites:

For downloading of Bidding Documents: <https://www.philgeps.gov.ph/> or  
<https://www.napocor.gov.ph/BCSD/bids.php>

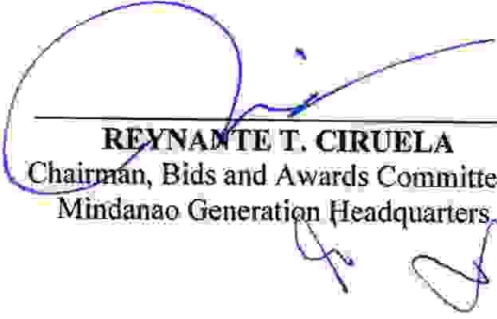

REYNANTE T. CIRUELA  
Chairman, Bids and Awards Committee  
Mindanao Generation Headquarters

**Date of PhilGEPS Publication:** 03 August 2022

**LIST OF PRIVATE SURETY COMPANIES ACCEPTABLE TO NPC  
AS OF 11 NOVEMBER 2018**

	<b>Name of Surety Company</b>	<b>Contact No.</b>
1	<b>ALPHA INSURANCE &amp; SURETY CO., INC.</b> Alpha Insurance Centre 1025 San Marcelino St., Ermita, Manila	<b>525-1301</b> <b>F - 522-6131</b>
2	<b>COMMONWEALTH INSURANCE COMPANY</b> 10/12F, BDO Plaza, 8737 Paseo de Roxas Makati City	<b>818-7626 loc 1253</b> <b>813-2685</b>
3	<b>COUNTRY BANKERS INSURANCE CORPORATION</b> Country Bankers Centre, 648 T. M. Kalaw Avenue Ermita, Manila	<b>524-0621 to 23</b>
4	<b>INTRA STRATA ASSURANCE CORP.</b> 8th Floor, 88 Corporate Center Building Sedeño cor. Valero St., Salcedo Vill, Makati City	<b>817-3031 to 34</b>
5	<b>LIBERTY INSURANCE CORPORATION</b> JCS Building, 119 Dela Rosa cor. Carlos Palanca Sts. Legaspi Village, Makati City	<b>819-1961 to 66</b>
6	<b>PACIFIC UNION INSURANCE COMPANY</b> Unit 2401 Antel Corporate Center 121 Valero St. Salcedo Village, Makati City	<b>845-1033 to 37</b>
7	<b>PRUDENTIAL GUARANTEE &amp; ASSURANCE, INC.</b> Coyuito House, 119 Palanca St. Legaspi Village, Makati City	<b>810-4916 to 35</b>
8	<b>STERLING INSURANCE COMPANY, INC.</b> 6F Zeta Annex II Building 191 Salcedo St., Legaspi Village, Makati City	<b>759-3082/759-2930/</b> <b>759-2921/</b> <b>892-3792</b>
9	<b>THE MERCANTILE INSURANCE CO. LTD.</b> Mercantile Insurance Building Corner General Luna & Beaterio Sts. Intramuros, Manila	<b>527-7701 to 20</b>
10	<b>TRAVELLERS INSURANCE SURETY CORPORATION</b> 10 <sup>th</sup> Floor, G. E. Antonio Building T.M. Kalaw corner J. Bocobo St., Ermita, Manila	<b>521-3822/400-9327</b>
11	<b>WESTERN GUARANTEE CORPORATION</b> Suite 508 BPI Office Condominium Plaza Cervantes, Binondo, Manila	<b>241-7401/242-1073</b>

**Note: Indicate in the performance, advance payment, retention and guarantee bond the following NPC Standard Terms & Conditions:**

- 1) The bond is a penal bond, callable on demand and the entire amount thereof shall be forfeited in favor of the Obligee upon default of the Principal without the need to prove or to show grounds or reasons for demand for the sum specified therein;
- 2) The amount claimed by the Obligee under this bond shall be paid in full and shall never be subject to any adjustment by the Surety;
- 3) In case of claim, the Surety shall pay such claim within sixty (60) days from receipt by the Surety of the Obligee's notice of claim/demand letter notwithstanding any objection thereto by the Principal.

4) *The proposed bond is valid until the issuance of NPC of the Cert. of Final Acceptance.*

## ***Section II. Instructions to Bidders***



## 1. Scope of Bid

The Procuring Entity, **NATIONAL POWER CORPORATION–MINDANAO GENERATION** invites Bids for the *Installation of Cylindrical Tank for Hyhdrotor Used Oil, NPC MinGen, Nangka, bala-I, Lanao del Norte, with Project Identification Number INFRA2022-AG5-052.*

The Procurement Project (referred to herein as “Project”) is for the construction of Works, as described in Section VI (Specifications).

## 2. Funding Information

2.1. The GOP through the source of funding as indicated below for CY 2022 in the amount of *One Million Three Hundred Thousand Pesos (PHP1,300,000.00)*

2.2. The source of funding is:

- a. GOCC and GFIs, the proposed Corporate Operating Budget.

## 3. Bidding Requirements

The Bidding for the Project shall be governed by all the provisions of RA No. 9184 and its 2016 revised IRR, including its Generic Procurement Manual and associated policies, rules and regulations as the primary source thereof, while the herein clauses shall serve as the secondary source thereof.

Any amendments made to the IRR and other GPPB issuances shall be applicable only to the ongoing posting, advertisement, or invitation to bid by the BAC through the issuance of a supplemental or bid bulletin.

The Bidder, by the act of submitting its Bid, shall be deemed to have inspected the site, determined the general characteristics of the contracted Works and the conditions for this Project, such as the location and the nature of the work; (b) climatic conditions; (c) transportation facilities; (c) nature and condition of the terrain, geological conditions at the site communication facilities, requirements, location and availability of construction aggregates and other materials, labor, water, electric power and access roads; and (d) other factors that may affect the cost, duration and execution or implementation of the contract, project, or work and examine all instructions, forms, terms, and project requirements in the Bidding Documents.

#### 4. Corrupt, Fraudulent, Collusive, Coercive, and Obstructive Practices

The Procuring Entity, as well as the Bidders and Contractors, shall observe the highest standard of ethics during the procurement and execution of the contract. They or through an agent shall not engage in corrupt, fraudulent, collusive, coercive, and obstructive practices defined under Annex "I" of the 2016 revised IRR of RA No. 9184 or other integrity violations in competing for the Project.

#### 5. Eligible Bidders

- 5.1. Only Bids of Bidders found to be legally, technically, and financially capable will be evaluated.
- 5.2. The Bidder must have an experience of having completed a Single Largest Completed Contract (SLCC) that is similar to this Project, equivalent to at least fifty percent (50%) of the ABC adjusted, if necessary, by the Bidder to current prices using the PSA's CPI, except under conditions provided for in Section 23.4.2.4 of the 2016 revised IRR of RA No. 9184.

A contract is considered to be "similar" to the contract to be bid if it has the major categories of work stated in the **BDS**.

- 5.3. For Foreign-funded Procurement, the Procuring Entity and the foreign government/foreign or international financing institution may agree on another track record requirement, as specified in the Bidding Document prepared for this purpose.
- 5.4. The Bidders shall comply with the eligibility criteria under Section 23.4.2 of the 2016 IRR of RA No. 9184.

#### 6. Origin of Associated Goods

There is no restriction on the origin of Goods other than those prohibited by a decision of the UN Security Council taken under Chapter VII of the Charter of the UN.

#### 7. Subcontracts

- 7.1. The Bidder may subcontract portions of the Project to the extent allowed by the Procuring Entity as stated herein, but in no case more than fifty percent (50%) of the Project.

The Procuring Entity has prescribed that:

- a. Subcontracting is not allowed.

## 8. Pre-Bid Conference

The Procuring Entity will hold a pre-bid conference for this Project on the specified date and time and either at its physical address **and/or through videoconferencing/webcasting** as indicated in paragraph 6 of the **IB**.

## 9. Clarification and Amendment of Bidding Documents

Prospective bidders may request for clarification on and/or interpretation of any part of the Bidding Documents. Such requests must be in writing and received by the Procuring Entity, either at its given address or through electronic mail indicated in the **IB**, at least ten (10) calendar days before the deadline set for the submission and receipt of Bids.

## 10. Documents Comprising the Bid: Eligibility and Technical Components

- 10.1. The first envelope shall contain the eligibility and technical documents of the Bid as specified in **Section IX, Checklist of Technical and Financial Documents**.
- 10.2. If the eligibility requirements or statements, the bids, and all other documents for submission to the BAC are in foreign language other than English, it must be accompanied by a translation in English, which shall be authenticated by the appropriate Philippine foreign service establishment, post, or the equivalent office having jurisdiction over the foreign bidder's affairs in the Philippines. For Contracting Parties to the Apostille Convention, only the translated documents shall be authenticated through an apostille pursuant to GPPB Resolution No. 13-2019 dated 23 May 2019. The English translation shall govern, for purposes of interpretation of the bid.
- 10.3. A valid PCAB License is required, and in case of joint ventures, a valid special PCAB License, and registration for the type and cost of the contract for this Project. Any additional type of Contractor license or permit shall be indicated in the **BDS**.
- 10.4. A List of Contractor's key personnel (e.g., Project Manager, Project Engineers, Materials Engineers, and Foremen) assigned to the contract to be bid, with their complete qualification and experience data shall be provided. These key personnel must meet the required minimum years of experience set in the **BDS**.
- 10.5. A List of Contractor's major equipment units, which are owned, leased, and/or under purchase agreements, supported by proof of ownership, certification of availability of equipment from the equipment lessor/vendor for the duration of the project, as the case may be, must meet the minimum requirements for the contract set in the **BDS**.

## 11. Documents Comprising the Bid: Financial Component

- 11.1. The second bid envelope shall contain the financial documents for the Bid as specified in **Section IX. Checklist of Technical and Financial Documents.**
- 11.2. Any bid exceeding the ABC indicated in paragraph 1 of the **IB** shall not be accepted.
- 11.3. For Foreign-funded procurement, a ceiling may be applied to bid prices provided the conditions are met under Section 31.2 of the 2016 revised IRR of RA No. 9184.

## 12. Alternative Bids

Bidders shall submit offers that comply with the requirements of the Bidding Documents, including the basic technical design as indicated in the drawings and specifications. Unless there is a value engineering clause in the **BDS**, alternative Bids shall not be accepted.

## 13. Bid Prices

All bid prices for the given scope of work in the Project as awarded shall be considered as fixed prices, and therefore not subject to price escalation during contract implementation, except under extraordinary circumstances as determined by the NEDA and approved by the GPPB pursuant to the revised Guidelines for Contract Price Escalation guidelines.

## 14. Bid and Payment Currencies

- 14.1. Bid prices may be quoted in the local currency or tradeable currency accepted by the BSP at the discretion of the Bidder. However, for purposes of bid evaluation, Bids denominated in foreign currencies shall be converted to Philippine currency based on the exchange rate as published in the BSP reference rate bulletin on the day of the bid opening.
- 14.2. *Payment of the contract price shall be made in:*
  - a. Philippine Pesos.

## 15. Bid Security

- 15.1. The Bidder shall submit a Bid Securing Declaration or any form of Bid Security in the amount indicated in the **BDS**, which shall be not less than the percentage of the ABC in accordance with the schedule in the **BDS**.
- 15.2. The Bid and bid security shall be valid until **One Hundred Twenty (120) Calendar Days from the Scheduled Bid Opening.** Any bid not accompanied

by an acceptable bid security shall be rejected by the Procuring Entity as non-responsive.

## **16. Sealing and Marking of Bids**

Each Bidder shall submit one copy of the first and second components of its Bid.

The Procuring Entity may request additional hard copies and/or electronic copies of the Bid. However, failure of the Bidders to comply with the said request shall not be a ground for disqualification.

If the Procuring Entity allows the submission of bids through online submission to the given website or any other electronic means, the Bidder shall submit an electronic copy of its Bid, which must be digitally signed. An electronic copy that cannot be opened or is corrupted shall be considered non-responsive and, thus, automatically disqualified.

## **17. Deadline for Submission of Bids**

The Bidders shall submit on the specified date and time and either at its physical address or through online submission as indicated in paragraph 7 of the **IB**.

## **18. Opening and Preliminary Examination of Bids**

18.1. The BAC shall open the Bids in public at the time, on the date, and at the place specified in paragraph 9 of the **IB**. The Bidders' representatives who are present shall sign a register evidencing their attendance. In case videoconferencing, webcasting or other similar technologies will be used, attendance of participants shall likewise be recorded by the BAC Secretariat.

In case the Bids cannot be opened as scheduled due to justifiable reasons, the rescheduling requirements under Section 29 of the 2016 revised IRR of RA No. 9184 shall prevail.

18.2. The preliminary examination of Bids shall be governed by Section 30 of the 2016 revised IRR of RA No. 9184.

## **19. Detailed Evaluation and Comparison of Bids**

19.1. The Procuring Entity's BAC shall immediately conduct a detailed evaluation of all Bids rated "*passed*" using non-discretionary pass/fail criteria. The BAC shall consider the conditions in the evaluation of Bids under Section 32.2 of 2016 revised IRR of RA No. 9184.

19.2. If the Project allows partial bids, all Bids and combinations of Bids as indicated in the **BDS** shall be received by the same deadline and opened and evaluated simultaneously so as to determine the Bid or combination of Bids

offering the lowest calculated cost to the Procuring Entity. Bid Security as required by **ITB** Clause 16 shall be submitted for each contract (lot) separately.

- 19.3. In all cases, the NFCC computation pursuant to Section 23.4.2.6 of the 2016 revised IRR of RA No. 9184 must be sufficient for the total of the ABCs for all the lots participated in by the prospective Bidder.

## **20. Post Qualification**

Within a non-extendible period of five (5) calendar days from receipt by the Bidder of the notice from the BAC that it submitted the Lowest Calculated Bid, the Bidder shall submit its latest income and business tax returns filed and paid through the BIR Electronic Filing and Payment System (eFPS), and other appropriate licenses and permits required by law and stated in the **BDS**.

## **21. Signing of the Contract**

The documents required in Section 37.2 of the 2016 revised IRR of RA No. 9184 shall form part of the Contract. Additional Contract documents are indicated in the **BDS**.

### ***Section III. Bid Data Sheet***

T

## Bid Data Sheet

ITB Clause																						
5.2	For this purpose, contracts similar to the Project refer to contracts which have the same major categories of work, which shall be: <b>Vertical Structures</b>																					
7.1	Subcontracting is not allowed.																					
10.3	None																					
10.4	<p>The key personnel must meet the required minimum years of experience set below:</p> <table border="1" style="width: 100%; border-collapse: collapse;"> <thead> <tr> <th style="text-align: center;"><u>Key Personnel</u></th> <th style="text-align: center;"><u>General Expertise</u></th> <th style="text-align: center;"><u>Relevant Experience</u></th> </tr> </thead> <tbody> <tr> <td style="text-align: center;">1 - Project Engineer</td> <td>Licensed Civil Engineer</td> <td>At least five (5) years experience in related works</td> </tr> <tr> <td style="text-align: center;">1 - Construction Foreman</td> <td>B.S. Civil Engineering Graduate</td> <td>At least three (3) years experience in similar works</td> </tr> <tr> <td></td> <td>Civil Engineering Technology Graduate</td> <td>At least five (5) years experience in similar works</td> </tr> <tr> <td></td> <td>Non-graduate</td> <td>At least five (5) years working experience as Construction Foreman in similar works</td> </tr> <tr> <td style="text-align: center;">1 - Construction Safety and Health Officer (SO2)</td> <td>Construction Safety Officer 2</td> <td>At least forty (40) hours of Construction Safety and Health (COSH) Training from Occupational Safety and Health Center (OSHC) or Safety Training Organizations (STOs) accredited by the Department of Labor and Employment (DOLE). Must be present during the whole duration of the project)</td> </tr> <tr> <td style="text-align: center;">2 - Welders</td> <td><u>NCH</u></td> <td>At least three (3) years experience in welding/cutting works</td> </tr> </tbody> </table>	<u>Key Personnel</u>	<u>General Expertise</u>	<u>Relevant Experience</u>	1 - Project Engineer	Licensed Civil Engineer	At least five (5) years experience in related works	1 - Construction Foreman	B.S. Civil Engineering Graduate	At least three (3) years experience in similar works		Civil Engineering Technology Graduate	At least five (5) years experience in similar works		Non-graduate	At least five (5) years working experience as Construction Foreman in similar works	1 - Construction Safety and Health Officer (SO2)	Construction Safety Officer 2	At least forty (40) hours of Construction Safety and Health (COSH) Training from Occupational Safety and Health Center (OSHC) or Safety Training Organizations (STOs) accredited by the Department of Labor and Employment (DOLE). Must be present during the whole duration of the project)	2 - Welders	<u>NCH</u>	At least three (3) years experience in welding/cutting works
<u>Key Personnel</u>	<u>General Expertise</u>	<u>Relevant Experience</u>																				
1 - Project Engineer	Licensed Civil Engineer	At least five (5) years experience in related works																				
1 - Construction Foreman	B.S. Civil Engineering Graduate	At least three (3) years experience in similar works																				
	Civil Engineering Technology Graduate	At least five (5) years experience in similar works																				
	Non-graduate	At least five (5) years working experience as Construction Foreman in similar works																				
1 - Construction Safety and Health Officer (SO2)	Construction Safety Officer 2	At least forty (40) hours of Construction Safety and Health (COSH) Training from Occupational Safety and Health Center (OSHC) or Safety Training Organizations (STOs) accredited by the Department of Labor and Employment (DOLE). Must be present during the whole duration of the project)																				
2 - Welders	<u>NCH</u>	At least three (3) years experience in welding/cutting works																				



	<p>1) Valid Professional Regulation Commission (PRC) license for professional personnel; (2) Certificate of Training with accreditation from DOLE for the Construction Safety &amp; Health Officer; (3) TESDA Training Certificate (NC II) of Welders, Electrician, Plumbers &amp; etc. (if applicable) ; and (4) Diploma and/or Service Record/Certificate of Employment of previous and/or current employer for Project Engineer, Safety Officer, Construction Foreman, Welders, Electrician &amp; Plumber, etc. (if applicable) <i>shall be submitted and included as an attachment in the Standard Form NPCMGNSF-INFR-05: List of Key personnel Proposed to be Assigned to the Contract.</i></p> <p>Project Engineer or Foreman and Construction Safety &amp; Health Officer maybe one person, as long as he meets the requirements of the two positions. Provided however, that there is no overlapping of projects undertaken by the same contractor and supervised by the same person.</p> <p>The above key personnel must be either employed by the applicant or contracted by the applicant to be employed for the contract to be bid.</p>															
<p>10.5</p>	<p>The minimum equipment requirements are the following:</p> <table border="1" data-bbox="446 1020 1324 1224"> <thead> <tr> <th><u>Equipment</u></th> <th><u>Capacity</u></th> <th><u>Number of Units</u></th> </tr> </thead> <tbody> <tr> <td>Welding Machine</td> <td>300 Amp</td> <td>Two (2)</td> </tr> <tr> <td>Concrete Mixer</td> <td>1-bagger</td> <td>One (1)</td> </tr> <tr> <td>Mini Dump Truck</td> <td>3.0 cu.m.</td> <td>One (1)</td> </tr> <tr> <td>Oxy/Acetylene with Tanks</td> <td>N/A</td> <td>One (1)</td> </tr> </tbody> </table>	<u>Equipment</u>	<u>Capacity</u>	<u>Number of Units</u>	Welding Machine	300 Amp	Two (2)	Concrete Mixer	1-bagger	One (1)	Mini Dump Truck	3.0 cu.m.	One (1)	Oxy/Acetylene with Tanks	N/A	One (1)
<u>Equipment</u>	<u>Capacity</u>	<u>Number of Units</u>														
Welding Machine	300 Amp	Two (2)														
Concrete Mixer	1-bagger	One (1)														
Mini Dump Truck	3.0 cu.m.	One (1)														
Oxy/Acetylene with Tanks	N/A	One (1)														
<p>12</p>	<p>N/A</p>															
<p>15.1</p>	<p>The bid security shall be in the form of a Bid Securing Declaration or any of the following forms and amounts:</p> <ol style="list-style-type: none"> <li>a. The amount of not less than <b>PHP 26,000.00 (2% of ABC)</b>, if bid security is in cash, cashier's/manager's check, bank draft/guarantee or irrevocable letter of credit;</li> <li>b. The amount of not less than <b>PHP 65,000.00 (5% of ABC)</b>, if bid security is in Surety Bond.</li> </ol>															
<p>19.2</p>	<p>Partial bids are allowed, as follows:</p>															
<p>20</p>	<p>Additional documents to be submitted during Post-Qualification:</p> <ol style="list-style-type: none"> <li>1. Other appropriate licenses and permits required by law and stated in the Bidding documents.             <ol style="list-style-type: none"> <li>a. <i>Original Bank Statement year ending prior to bid opening;</i></li> <li>b. <i>Valid and updated PhilGEPS Registration (Platinum Membership) (all pages);</i></li> </ol> </li> </ol>															

	<ul style="list-style-type: none"> <li>c. <i>Registration Certificate from Securities and Exchange Commission (SEC), Department of Trade and Industry (DTI) for sole proprietorship, or Cooperative Development Authority (CDA) for cooperatives or its equivalent document;</i></li> <li>d. <i>Mayor's or Business permit issued by the city or municipality where the principal place of business of the prospective bidder is located, or the equivalent document for Exclusive Economic Zones or Areas;</i></li> <li>e. <i>Valid Tax clearance per E.O. No. 398, s. 2005, as finally reviewed and approved by the Bureau of Internal Revenue (BIR). Quarterly Income Tax Returns filed and paid through the BIR Electronic Filing and Payment System (eFPS);</i></li> <li>f. <i>The prospective bidder's audited financial statements, showing, among others, the prospective bidder's total and current assets and liabilities, stamped "received" by the BIR or its duly accredited and authorized institutions, for the preceding calendar year which should not be earlier than two (2) years from the date of bid submission;</i></li> <li>g. <i>Philippine Contractors Accreditation Board (PCAB) License;</i></li> <li>h. <i>Board of Accountancy (BOA) Certificate;</i></li> </ul> <ol style="list-style-type: none"> <li>2. <i>Contract and/or Notice of Award as supporting documents for NPC MinGen Form No. NPCMGNSF-INFRA-01, if applicable;</i></li> <li>3. <i>Certificate of Site Inspection issued by Plant/Department Manager or his authorized representative.</i></li> </ol>
<p>21</p>	<p>Additional contract documents relevant to the Project that may be required by existing laws and/or the Procuring Entity, <u>prior to contract signing</u>, such as:</p> <ul style="list-style-type: none"> <li>a) Approved construction schedule and S-curve</li> <li>b) Approved manpower schedule</li> <li>c) Construction methods</li> <li>d) Approved equipment utilization schedule</li> <li>e) Construction safety and health program approved by the DOLE</li> <li>f) Approved Project Evaluation Review Technique/Critical Path Method (PERT/CPM)</li> </ul>

## ***Section IV. General Conditions of Contract***

T

## 1. Scope of Contract

This Contract shall include all such items, although not specifically mentioned, that can be reasonably inferred as being required for its completion as if such items were expressly mentioned herein. All the provisions of RA No. 9184 and its 2016 revised IRR, including the Generic Procurement Manual, and associated issuances, constitute the primary source for the terms and conditions of the Contract, and thus, applicable in contract implementation. Herein clauses shall serve as the secondary source for the terms and conditions of the Contract.

This is without prejudice to Sections 74.1 and 74.2 of the 2016 revised IRR of RA No. 9184 allowing the GPPB to amend the IRR, which shall be applied to all procurement activities, the advertisement, posting, or invitation of which were issued after the effectivity of the said amendment.

## 2. Sectional Completion of Works

If sectional completion is specified in the **Special Conditions of Contract (SCC)**, references in the Conditions of Contract to the Works, the Completion Date, and the Intended Completion Date shall apply to any Section of the Works (other than references to the Completion Date and Intended Completion Date for the whole of the Works).

## 3. Possession of Site

- 4.1. The Procuring Entity shall give possession of all or parts of the Site to the Contractor based on the schedule of delivery indicated in the **SCC**, which corresponds to the execution of the Works. If the Contractor suffers delay or incurs cost from failure on the part of the Procuring Entity to give possession in accordance with the terms of this clause, the Procuring Entity's Representative shall give the Contractor a Contract Time Extension and certify such sum as fair to cover the cost incurred, which sum shall be paid by Procuring Entity.
- 4.2. If possession of a portion is not given by the above date, the Procuring Entity will be deemed to have delayed the start of the relevant activities. The resulting adjustments in contract time to address such delay may be addressed through contract extension provided under Annex "E" of the 2016 revised IRR of RA No. 9184.

## 4. The Contractor's Obligations

The Contractor shall employ the key personnel named in the Schedule of Key Personnel indicating their designation, in accordance with **ITB** Clause 10.3 and specified in the **BDS**, to carry out the supervision of the Works.

The Procuring Entity will approve any proposed replacement of key personnel only if their relevant qualifications and abilities are equal to or better than those of the personnel listed in the Schedule.

**5. Performance Security**

- 5.1. Within ten (10) calendar days from receipt of the Notice of Award from the Procuring Entity but in no case later than the signing of the contract by both parties, the successful Bidder shall furnish the performance security in any of the forms prescribed in Section 39 of the 2016 revised IRR.
- 5.2. The Contractor, by entering into the Contract with the Procuring Entity, acknowledges the right of the Procuring Entity to institute action pursuant to RA No. 3688 against any subcontractor be they an individual, firm, partnership, corporation, or association supplying the Contractor with labor, materials and/or equipment for the performance of this Contract.

**6. Site Investigation Reports**

The Contractor, in preparing the Bid, shall rely on any Site Investigation Reports referred to in the SCC supplemented by any information obtained by the Contractor.

T

**7. Warranty**

- 7.1. In case the Contractor fails to undertake the repair works under Section 62.2.2 of the 2016 revised IRR, the Procuring Entity shall forfeit its performance security, subject its property(ies) to attachment or garnishment proceedings, and perpetually disqualify it from participating in any public bidding. All payables of the GOP in his favor shall be offset to recover the costs.
- 7.2. The warranty against Structural Defects/Failures, except that occasioned-on force majeure, shall cover the period from the date of issuance of the Certificate of Final Acceptance by the Procuring Entity. Specific duration of the warranty is found in the SCC.

**8. Liability of the Contractor**

Subject to additional provisions, if any, set forth in the SCC, the Contractor’s liability under this Contract shall be as provided by the laws of the Republic of the Philippines.

If the Contractor is a joint venture, all partners to the joint venture shall be jointly and severally liable to the Procuring Entity.

**9. Termination for Other Causes**

Contract termination shall be initiated in case it is determined *prima facie* by the Procuring Entity that the Contractor has engaged, before, or during the implementation of the contract, in unlawful deeds and behaviors relative to contract acquisition and implementation, such as, but not limited to corrupt, fraudulent, collusive, coercive, and obstructive practices as stated in ITB Clause 4.

## 10. Dayworks

Subject to the guidelines on Variation Order in Annex "E" of the 2016 revised IRR of RA No. 9184, and if applicable as indicated in the SCC, the Dayworks rates in the Contractor's Bid shall be used for small additional amounts of work only when the Procuring Entity's Representative has given written instructions in advance for additional work to be paid for in that way.

## 11. Program of Work

- 11.1. The Contractor shall submit to the Procuring Entity's Representative for approval the said Program of Work showing the general methods, arrangements, order, and timing for all the activities in the Works. The submissions of the Program of Work are indicated in the SCC.
- 11.2. The Contractor shall submit to the Procuring Entity's Representative for approval an updated Program of Work at intervals no longer than the period stated in the SCC. If the Contractor does not submit an updated Program of Work within this period, the Procuring Entity's Representative may withhold the amount stated in the SCC from the next payment certificate and continue to withhold this amount until the next payment after the date on which the overdue Program of Work has been submitted.

## 12. Instructions, Inspections and Audits

The Contractor shall permit the GOP or the Procuring Entity to inspect the Contractor's accounts and records relating to the performance of the Contractor and to have them audited by auditors of the GOP or the Procuring Entity, as may be required.

## 13. Advance Payment

The Procuring Entity shall, upon a written request of the Contractor which shall be submitted as a Contract document, make an advance payment to the Contractor in an amount not exceeding fifteen percent (15%) of the total contract price, to be made in lump sum, or at the most two installments according to a schedule specified in the SCC, subject to the requirements in Annex "E" of the 2016 revised IRR of RA No. 9184.

#### **14. Progress Payments**

The Contractor may submit a request for payment for Work accomplished. Such requests for payment shall be verified and certified by the Procuring Entity's Representative/Project Engineer. Except as otherwise stipulated in the SCC, materials and equipment delivered on the site but not completely put in place shall not be included for payment.

#### **15. Operating and Maintenance Manuals**

- 15.1. If required, the Contractor will provide "as built" Drawings and/or operating and maintenance manuals as specified in the SCC.
- 15.2. If the Contractor does not provide the Drawings and/or manuals by the dates stated above, or they do not receive the Procuring Entity's Representative's approval, the Procuring Entity's Representative may withhold the amount stated in the SCC from payments due to the Contractor.

## ***Section V. Special Conditions of Contract***



## Special Conditions of Contract

GCC Clause	
2	<b>Sectional completion is not specified.</b>
4.1	The <b>Procuring Entity</b> shall give possession of the Site to the Contractor <i>on the start date</i> .
6	The site investigation reports are: <b>NONE</b>
7.2	<b>Fifteen (15) years</b>
10	Dayworks are not applicable to the contract.
11.1	The Contractor shall submit the Program of Work to the Procuring Entity's Representative <b>upon contract signing</b> or within <b>three (3)</b> days of delivery of the Notice of Award.
11.2	The amount to be withheld for late submission of an updated Program of Work is <b>Fifty (50) %</b> of the billed amount. The updating of Program of Work shall be done bi-monthly.
13	The amount of the advance payment is <b>15% of contract amount and paid in lump sum.</b>
14	No further instruction.
15.1	The date by which operating and maintenance manuals are required is <b>upon completion of the project.</b>  The date by which "as built" drawings are required is <b>upon completion of the project.</b>
15.2	The amount to be withheld for failing to produce "as built" drawings and/or operating and maintenance manuals by the date required is <b>one hundred percent (100%) of the final billing.</b>

## *Section VI. Specifications*

## PROJECT HIGHLIGHTS

### PH-1.0 GENERAL

The purpose of this project is to address the problem encountered during replacement of lubricating/hydraulic oil due to unavailability of storage tank for used and contaminated oil because all oil drums were fully occupied filtered used oil. During last audit conducted by NPC/PSALM it is highly recommended for the immediate transfer of existing old stock used hydrotor oil to proper storage tank the power cavern area.

### PH-2.0 PROJECT LOCATION

The project is located at NPC Agus 4 HE Plant, Nangka, Balo-I, Lanao del Norte

### PH-3.0 SCOPE OF WORK

The work and services to be performed by the Contractor for this undertaking shall essentially consist of, but not limited to the following:

- A. Mobilization/establishment of Contractors complete construction camp and other facilities;
- B. CONSTRUCTION SAFETY AND HEALTH PROGRAM (To provide safety signages, fire extinguisher and PPE's on the whole duration of the project. First aid kit must be present at the site and shall be turned-over to NPC after the completion of the project, if not used.)
- C. PURCHASE ( SUPPLY , DELIVERY AND INSTALL) OF FABRICATED CYLINDRICAL TANK, 14,000 LTRS.
- D. SITE CLEARING
- E. LAY-OUT AND STAKING
- F. EXCAVATION WORKS
- G. EMBANKMENT WORKS
- H. CONCRETE WORKS
- I. MASONRY WORKS
- J. STEEL STRUCTURE
- K. FABRICATION WORKS
- L. ROOFING WORKS
- M. PAINTING WORKS
- N. Demobilization including clearing of site/demolition of Contractor's camp facilities.

### PH-4.0 CONTRACT PERIOD

The contractor shall complete the works as specified in Clause 3 within **Eighty (80) calendar days**. The total contract duration is inclusive of six (6) unworkable days considered unfavorable for the execution of work at site. The contract period shall be reckoned from the date of contract effectivity as specified in the Notice to Proceed

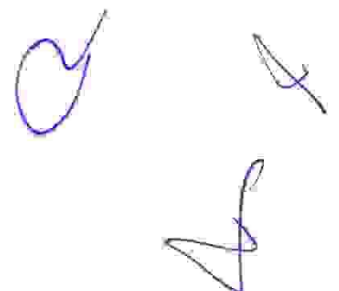

**PH-5.0 CONTRACTOR'S CLASSIFICATION**

The contractor must have a valid Philippine Contractor's Accreditation Board (PCAB) license of at least **Category C or D – General Building** with inter-agency registration of at least **Small B – Building and Industrial Plant**

The contractor must have undertaken similar contracts that involves electrical system and lightning protection system provided that the contract cost shall be at least equivalent to 50% of ABC

## TECHNICAL SPECIFICATIONS

### TS – 1.1 Scope

This section covers the construction and/or maintenance of access roads, drainage system and other appurtenant structures, moving-in of the Contractor's construction equipment, setting up of the Contractor's camp and the disposition of the Contractor's various facilities at the end of the Contract.

### TS – 1.2 Moving-in

The contractor shall bring to the site all his necessary construction equipment and plant and install all stationary construction equipment and plant at location and in the manner approved by the NPC. The Contractor shall submit sufficient detailed plans showing the proposed location of such stationary equipment and plant and other pertinent data. No installation of such stationary equipment shall be undertaken unless the corresponding plans have been approved by the NPC.

### TS – 1.3 Contractor's Camp Facilities

The Contractor shall provide and grade his camp site, construct his camp, employee housing, warehouse, machine and repair shops, fuel storage tanks and provide such related facilities and sanitary conveniences that the Contractor deems necessary for maintaining health, peace and order in the camp and work areas. The areas that may be used by the Contractor within the plant site shall be designated by the NPC.

The Contractor shall provide, maintain and operate, under competent direction, such camps and facilities as are necessary for the housing, feeding and accommodation of his employees.

### TS – 1.4 Water Supply

The Contractor shall, at his own expense, be responsible for the supply, installation, operation and maintenance of a safe and adequate supply of drinking and domestic water.

### TS – 1.5 Sewerage Disposal and Sanitation

The Contractor shall, at his own expense, be responsible for the installation, operation and maintenance of an adequate sewerage disposal and sanitation system and shall provide adequate toilet and wash-up facilities for his employees at his camp and in the areas where work is being carried out.

The Contractor shall execute the work with due regard to adequate sanitary provisions and applicable codes and shall take all necessary steps to prevent the pollution of water in any spring, river, or other



sources of water supply. All toilets or wash-up facilities shall be subject to the prior and continuing approval of the NPC.

#### **TS – 1.6 Fire Protection**

The Contractor shall observe all necessary precautions against fire, shall provide and maintain at his own expense, portable fire-fighting equipment he may deem necessary, and shall comply with all applicable laws of the Philippines relating thereto.

In the event of an uncontrollable fire occurring in the area of the Contractor's operation, the Contractor shall have to extinguish the fire immediately at his own expense, to the full extent of the manpower and equipment employed under the contract at the time of the fire.

The Contractor shall indemnify NPC against all liabilities, claims, damages and/or lawsuits arising thereto.

#### **TS – 1.7 Construction Power**

The Construction shall be responsible for providing his own electric power supply required for construction and erection/installation. If power is available from NPC and should the Contractor elect to utilize the NPC's power supply, he shall make an arrangement with NPC concerned group as to the billing rates and other requirements needed for direct connection to NPC.

#### **TS - 1.8 Camp Security**

The Contractor shall provide his own security force to the extent that he deems necessary for maintaining peace and order in the camp and work areas and to safeguard materials and equipment. Nothing under the provisions of this paragraph shall relieve the Contractor from full responsibility for the maintenance of peace and order and protection of life and property in all areas where he operates.

#### **TS – 1.9 Construction Material Storage**

The Contractor is required to put up warehouse(s) with capacities sufficient to store the construction materials required in the work. the warehouse(s) shall be specifically for this contract, notwithstanding his other facilities in the site that may serve the purpose.

#### **TS – 1.10 Removal of Camp and Construction Facilities**

After the completion of the work covered by the contract and prior to acceptance of the completed work, the entire camp facilities of the Contractor, including its water supply system, electric distribution system, quarters, warehouses, shops, dining halls, commissaries, temporary shed and other facilities therein shall be removed by the Contractor. The site shall be cleared and cleaned as directed by the NPC.

**TS – 1.11 Measurement and Payment**

No separate measurement and payment will be made for the Contractor's Construction Facilities. The entire cost thereof shall be included in the various pay items in the Bill of Quantities.

**TS – 2.0 CARE OF WATER DURING CONSTRUCTION****TS – 2.1 Scope**

In accordance with the specifications contained in this section or otherwise directed, the Contractor shall construct and maintain all necessary temporary drainage ditches and other temporary protective works and he shall also furnish, install, maintain and operate necessary pumping equipment and other devices to protect construction operation free from water coming from any source, including rain.

**TS – 2.2 Drainage and Dewatering**

The Contractor shall be responsible for dewatering foundation areas so that work can be carried out on a suitably dry condition. The Contractor shall construct drainage ditches, holes, culverts, furnish, maintain and operate at his own expense all necessary pumps and other dewatering devices to keep all work area free from water.

After the work is completed and before it is accepted by the NPC, the Contractor shall remove all pumping equipment and shall remove, fill or plug all temporary drainage structures as directed, all at his expense.

**TS – 2.3 Measurement and Payment**

No separate measurement and payment will be made for the Care of Water during Construction operations. The cost of furnishing, constructing, maintaining, operating and removing of temporary drainage structure, pumping system and other dewatering devices necessary to keep construction operations free from water, shall be included in the various pay items in the Bill of Quantities for structures where such care of water is required.

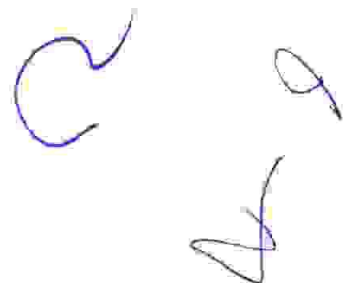

**TS-03 CONSTRUCTION SAFETY AND HEALTH PROGRAM****TS – 3.1 Scope**

This Section pertains to the environmental and safety provisions, requirements and conditions that shall govern during the execution of all civil works under this project.

**TS – 3.2 General Conditions**

The Contractor shall ensure compliance with the applicable environmental and safety regulations, as well as ECC conditions, during installation/construction of this project through the implementation of measures that include, but not limited to the following:

- a. Designate a Safety Officer and a Pollution Control Officer who shall respectively handle all safety and environmental concerns of the project.
- b. Prepare and submit Construction Safety Health Plan (CSHP)
- c. Properly manage debris and various waste generated during installation/construction, such as the following:
  - Dispose of demolition and construction debris in a designated or NPC approved disposal area (at the back of Central Warehouse near NGCP Switchyard Gate;
  - Stockpile (and cover if possible) or haul to the designated and/or pre developed dump sites (spoil disposal areas) that shall be provided with suitable drainage-equipped with sediments traps, stripped top soil, spoils from quarry/borrow sites and excavated materials;
  - Segregate solid wastes, such as empty cement sacks, scraps of tin or wood, used wires and other domestic, garbage, for recycling or storage in NPC-approved temporary storage areas and further disposal to LGU-designated disposal sites
  - Properly handle, store and dispose off, through DENR-accredited transporter/treater, hazardous wastes i.e. used oils, paints, thinner, Etc.
- d. Limit construction activities that generate excessive noise to daytime works only to prevent nuisance to nearby residents during rest hours.
- e. As far as practicable, undertake site stripping, grading and excavation during dry weather.
- f. Construction/Installation shall be carried-out in a manner where landslides and erosions are minimized.

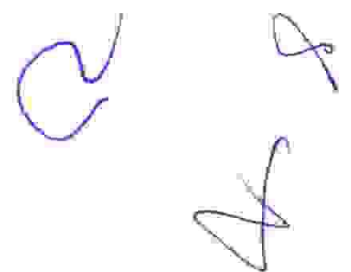



- g. Avoid unnecessary opening/clearing of areas outside construction sites or destruction of vegetable cover, especially cutting of existing trees; and to revegetate disturbed areas.
- h. Spray water, whenever and wherever necessary, to minimize dust generation.
- i. Provide PPE's and other safety provisions required by DOLE, for its project/site works.
- j. Submit proof of Tool Box meeting that was conducted in the course of the project. This will be attached on the contractor's progress billing.
- k. Composition of Occupational Safety and Health Team shall be displayed on the construction site or on the camp facilities that is visible to NPC inspectors and the construction workers. The size of the tarpaulin shall be 1.0m x 1.0m
- l. First aid kit (1 set) and ABC fire extinguishers ( 1set-20lbs) shall be present in the camp facilities and shall be turn-over to NPC after the completion of the project.

### TS – 3.3 Measurement and Payment

Measurement and payment shall be made at the contract unit price or lot price as specified in the Bid Price Schedule. Payment shall include all cost in furnishing labor, materials, tools equipment and other incidentals necessary for the satisfactory implementation of this requirements.

### TS-04 EXCAVATION WORKS

#### General

The work to be executed under this section shall include the furnishing of all, labor, tools and other facilities necessary for the satisfactory performance of all work necessary to complete the works specified in this specifications.

This Item shall include necessary diverting of live streams, bailing, pumping, draining, sheeting, bracing, and the necessary construction of cribs, and furnishing the materials therefore, and the subsequent removal of cribs and the placing of all necessary backfill.

It shall also include the furnishing and placing of approved foundation fill material to replace unsuitable material encountered below the foundation elevation of structures.

#### Construction Requirements

The Contractor shall notify the Engineer sufficiently in advance of the beginning of any excavation so that cross-section a elevations and

measurements may be taken on the undisturbed ground. The natural ground adjacent to the structures shall not be disturbed without permission of the Engineer.

Trenches or foundation pits for structures or structure footings shall be excavated to the lines and grades or elevations shown on the Plans or as staked by the Engineer. They shall be of sufficient size to permit the placing of structures or structure footings of the full width and length shown. The elevations of the bottoms of footings, as shown on the Plans, shall be considered as approximate only and the Engineer may order, in writing, such changes in dimensions or elevations of footings as may be deemed necessary, to secure a satisfactory foundation.

Boulders, logs, and other objectionable materials encountered in excavation shall be removed.

After each excavation is completed, the Contractor shall notify the Engineer to that effect and no footing, bedding material or pipe culvert shall be placed until the Engineer has approved the depth of excavation and the character of the foundation material.

All rock or other hard foundation materials shall be cleaned of all loose materials, and cut to a firm surface, either level, stepped, or serrated as directed by the Engineer. All seams or crevices shall be cleaned and grouted. All loose and disintegrated rocks and thin strata shall be removed.

When the footing is to rest on material other than rock, excavation to final grade shall not be made until just before the footing is to be placed. When the foundation material is soft or mucky or otherwise unsuitable, as determined by the Engineer, the Contractor shall remove the unsuitable material and backfill with approved granular material. This foundation fill shall be placed and compacted in 150mm (6 inches) layers up to the foundation elevation.

#### **Utilization of Excavated Materials**

All excavated materials, so far as suitable, shall be utilized as backfill or embankment. The surplus materials shall be disposed off in such manner as not to obstruct the stream or otherwise impair the efficiency or appearance of the structure. No excavated materials shall be deposited at anytime so as to endanger the partly finished structure.

#### **MEASUREMENT AND PAYMENT**

Measurement and payment shall be made at the contract unit price or lot price as specified in the Bid Price Schedule. Payment shall include all cost in furnishing labor, materials, tools equipments and other incidentals necessary for the satisfactory completion of the project.

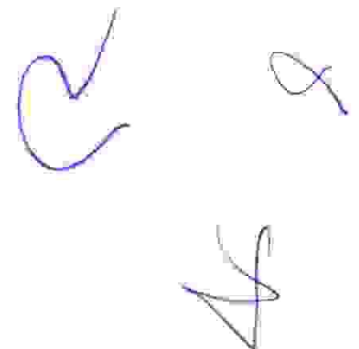

**TS-05 BACKFILLING WORKS****General**

The work to be executed under this section shall include the furnishing of all, labor, tools, equipment and other facilities necessary for the satisfactory performance of all work necessary to complete the works specified in this specifications.

**Material Requirements**

Embankments shall be constructed of suitable materials, in consonance with the following definitions:

**Suitable Material**—Material which is acceptable in accordance with the Contract and which can be compacted in the manner specified in this Item. It can be common material or rock.

**Selected Borrow, for topping**— soil of such gradation that all particles will pass a sieve with 75mm (3 inches) square openings and not more than 15 mass percent will pass the 0.075mm (No. 200) sieve, as determined by AASHTO T 11. The material shall have a plasticity index of not more than 6 as determined by ASSHTO T 90 and a liquid limit of not more than 30 as determined by AASHTO T 89.

**Unsuitable Material**—Material other than suitable materials such as:

- (a) Materials containing detrimental quantities of organic materials, such as grass, roots and sewerage.
- (b) Organic soils such as peat and muck.
- (c) Soils with liquid limit exceeding 80 and/or plasticity index exceeding 55.
- (d) Soils with a natural water content exceeding 100%.
- (e) Soils with very low natural density, 800kg/m<sup>3</sup> or lower.
- (f) Soils that cannot be properly compacted as determined by the Engineer.

**Construction Requirements**



**General**

Prior to backfilling works, all necessary clearing and grubbing in that area shall have been performed.

Backfills shall contain no muck, peat, sod, roots or other deleterious matter. Rocks, broken concrete or other solid, bulky materials shall not be placed in embankment areas where pilings are to be placed or driven.

Where shown on the Plans or directed by the Engineer, the surface of the existing ground shall be compacted to a depth of 150mm (6 inches) and to the specified requirements of this Item.

**Methods of Construction**

Backfill of earth material shall be placed in horizontal layers not exceeding 200mm (8 inches), loose measurement, and shall be compacted as specified before the next layer is placed. However, thicker layer may be placed if vibratory roller with high compactive effort is used provided that density requirement is attained and as approved by the Engineer. Trial section to this effect must be conducted and approved by the Engineer. Effective spreading equipment shall be used on a chert to obtain uniform thickness as determined in the trial section prior to compaction. As the compaction of each layer progresses, continuous leveling and manipulating will be required to assure uniform density. Water shall be added or removed, if necessary, in order to obtain the required density. Removal of water shall be accomplished through aeration by plowing, blading, discing, or other methods satisfactory to the Engineer.

**Compaction**

The Contractor shall compact the material placed in all embankment layers and the material scarified to the designated depth until a uniform density of not less than 95 mass percent of the maximum dry density determined by AASHTOT

**MEASUREMENT AND PAYMENT**

Measurement and payment shall be made at the contract unit price or lot price as specified in the Bid Price Schedule. Payment shall include all cost in furnishing labor, materials, tools equipment and other incidentals necessary for the satisfactory completion of the project.

**TS - 06 CONCRETE WORKS****GENERAL**

The work to be undertaken under this Section shall include all labor, materials, equipment, plant and other facilities and the satisfactory

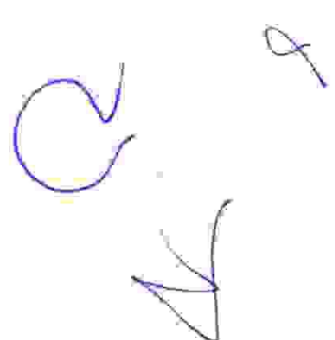

performance of all work necessary to complete all concrete work shown on the drawings and specified herein.

**MATERIALS**

**a) Cement**

Except as maybe otherwise provided in these specifications, cement shall conform to the "Specification for Portland Cement" (ASTM C 150 - Latest Revision) and shall be Type I

**b) Concrete Aggregates**

- 1.) Concrete aggregates shall be well graded, clean, hard particles of gravel or crushed rock conforming with the "Standard Specifications for Concrete Aggregates ( ASTM C - 33 Latest Revision).
- 2.) The maximum size of the aggregates shall not be larger than one-fifth (1/5) of the narrowest dimension between form and not larger than three fourth (3/4) of the minimum clear spacing between individual reinforcing bars or bundles of bars, and in no case larger 5.1 cm (2 in) in diameter except that larger diameter may be allowed in massive concreting with written permission from the Engineer.

**c) Water**

Water used in mixing concrete shall be clean and free from injuring amounts of oils, acids, alkali, organic materials or other substances that may be deleterious to concrete or steel.

**d) Reinforcing Steel**

All reinforcing steel bars used shall be new and free from rust, oil, defects, greases or kinks. They shall conform to the latest edition of ASTM "SPECIFICATIONS FOR DEFORMED STEEL BARS FOR CONCRETE REINFORCEMENT" Grade 40 as shown or latest equivalent Philippine Bureau of Standard Specifications. Deformed Steel Bars shall have the following unit weights:

SIZE (mm)	Kg/m	SIZE (mm)	Kg/m
6	0.222	20	2.466
8	0.395	25	3.854
10	0.616	28	4.833
12	0.888	32	6.313
16	1.579	36	7.991

**e) Admixture:**

To increase concrete workability and to control the set of concrete, the engineer can request that an admixture maybe added subject to his approval and it shall be borne by the Contractor.

Water – reducing admixtures, retarding admixtures, accelerating admixtures, water-reducing and retarding admixtures, and water reducing and accelerating admixtures shall conform to "Specification for Chemical Admixtures for Concrete" (ASTM C494).

Other admixtures required for specific construction conditions and conforming to ASTM (C494) "Standard Specification for Chemical Admixtures for Concrete" maybe incorporated in separate concrete design mixes and submitted to the responsible engineer for approval prior to their use.

### STORAGE OF MATERIALS

Cement and aggregates shall be stored in such a manner as to prevent deterioration or intrusion by foreign matter. Any material which has deteriorated or which has been damaged shall not be used for concrete. Steel shall be stored under cover or otherwise prevented from rusting.

### CONTROLLED STRENGTHS OF CONCRETE

- 1.0.1 Concrete for structural elements shall develop a minimum **28-day compressive cylinder strength of 20.68 MPa (3,000 psi)**, unless otherwise specified in the plans.
- 1.0.2 Concrete for non-structural elements such as cradles, unreinforced encasements, thrust blocks, and partition walls shall develop a minimum **28-day compressive cylinder strength of 17.25 mega Pascal (2,500 psi)**, unless otherwise specified in the plans

### CONCRETE PROPORTION AND CONSISTENCY

- a. The proportions of aggregate to cement for any concrete shall be such as to produce a mixture which will work readily into the corners and angles of the forms and around reinforcement with the method of placing employed on the work but without permitting the materials to segregate, or excess free water to collect on the surface. The combined aggregates shall be of such composition of sizes that when separated on the No. 4 standard sieve, the weight passing the sieve (fine aggregate) shall not be less than thirty percent (30%) of the total except that these proportions do not necessarily apply to lightweight aggregates.
- b. The methods of measuring concrete materials shall be such that proportions can be accurately controlled and easily checked at any time during the work. Measurement of materials for ready-mixed concrete



shall conform with the "Standard Specifications for Ready mixed Concrete" (ASTM C-94, Latest Revision) where applicable.

- c. Aggregates shall be measured out by weight and to within one percent (1%). Cement shall conform to 40 kg (88 lb.) per bag and this is to be verified from time to time. Water shall be measured by weight or volume to within one and one half (1-1/2 %).
- d. The water shall in no case exceed 21.24 liters, and 25.67 liters (5.62 and 6.79 US gallons) per bag of cement for all concrete with specified strength of f<sub>c</sub> respectively. Slumps shall be within the following limits:

Portion of Structure	Slump Millimeters	Inches
Columns and end supported beams, girders	50-100	2-4
Walls and thin Vertical sections	75-125	3-5
Footings, slabs on Grade and cantilevered beams and slabs	50-80	2-3

Slumps shall be according to "Test of Slump for Portland Cement Concrete" (ASTM C-143).

- e. **Classification and Design Mixture.** The mixtures for all classes of concrete shall be designed by the Contractor and approved by ICWS to obtain the compressive strength at the age of twenty eight (28) days as specified below.

Class	Size of Maximum Dia. of Aggregate	Minimum Compressive Strength	Designated Size of aggregate
Y	1/2" (12.5mm)	3,000 psi	12.5mm to 4.75mm
AA	3/4" (19mm)	3,000 psi	19mm to 4.75mm
A	1-1/2" (37.5mm)	3,000 psi	37.5mm to 4.75mm
B	2" (50mm)	2,400 psi	50mm to 4.75mm
C	3" (75mm)	2,400 psi	75mm to 4.75mm

- f. **Cement Content.** The minimum cement content per cubic meter of concrete for the different classes or gradation of aggregates shall be in accordance with the following:

Class and Gradation of Aggregates	Minimum Cement Content
Y with 1/2"	400 kgs/cu.m
AA with 3/4"	400 kgs/cu.m
A with 1-1/2"	360 kgs/cu.m
B with 2"	600 kgs/cu.m
C with 3"	270 kgs/cu.m
Z with 3"	340 kgs/cu.m

- g. Job mix adjustments on water content shall be allowed only with Engineer's permission and provided that cement is also added to maintain the original water cement ratio of the design mix.

**EXCLUSION OF WATER**

No concrete shall be placed in any structure until all water entering the space to be filled with concrete has been properly cut off or has been diverted by pipes, or other means, and carried out of the forms, clear of the work. No concrete shall be deposited under water without the explicit permission of the Engineer, and then only in strict accordance with his directions; nor shall the Contractor, without explicit permission allow still water to rise on any concrete until the concrete has attained its initial set. Water shall not be permitted to flow over the surface of any concrete in such manner and at such velocity as will injure the surface finish of the concrete. Pumping or other necessary dewatering operations for removing ground water, if required, will be subject to the approval of the Engineer.

**MIXING CONCRETE**

No hand mixing shall be allowed, except in case of emergency such as mixer breakdown during pouring operations and shall stop at the first allowed construction joints. All concrete shall be machine mixed for at least 1 minutes after all materials including water are in the mixing drum.

The mixer shall be of approved size and type which will insure a uniform distribution of material throughout the mass, it shall be equipped with a device for accurately measuring and controlling amount of water in each batch.

Placing of material in mixer shall be done in such a way that first batch of concrete materials placed in the mixer shall contain sufficient excess of



cement, sand and water to coat the inside of the drum without reducing the cement content of the mix to be discharged.

Retempering, i.e. , remixing with the addition of water to concrete that has been partially hardened shall not be permitted.

### PREPARATION OF SURFACES FOR CONCRETING

Earth surfaces shall be thoroughly wetted by sprinkling prior to the placing of any concrete, and these surfaces shall be kept moist by frequent sprinkling up to the time of placing concrete thereon. The surface shall be free from standing water, mud, and debris at the time of placing concrete.

Concrete surfaces upon or against which concrete is to be placed, where the placement of the old concrete has been stopped or interrupted so that, in the opinion of the Engineer, the new concrete cannot be incorporated integrally with that previously placed, are defined as construction joints. The surfaces of horizontal joints shall be leveled with a wooden float to provide a reasonably smooth surface. A surface consisting largely of coarse aggregate shall be avoided. Except where the drawings call for joint surfaces to be painted, the joint surfaces shall be cleaned of all laitance, loose or defective concrete, and foreign material. Such cleaning shall be accompanied by sandblasting followed by thorough washing. All pools of water shall be removed from the surface of construction joints before the new concrete is placed. After the surfaces have been prepared to the satisfaction of the Engineer, all approximately horizontal construction joints shall be covered with a layer of mortar approximately 25mm (1") thick. The mortar shall have the same proportion of cement and sand as the regular concrete mixture, unless otherwise directed by the Engineer. The water-cement ratio of the mortar in place shall not exceed that of the concrete to be placed upon it, and the consistency of the mortar shall be suitable for placing and working in a manner hereinafter specified. The mortar shall be spread uniformly and shall be worked thoroughly into all irregularities of the surface, and wire brooms shall be used where possible to scrub the mortar into the surface. Concrete shall be placed immediately upon the fresh mortar.

When placing of concrete is to be interrupted long enough for the concrete to take a set, the working face shall be given a shape by the use of forms or other means that will secure proper union with subsequent work, provided that construction joints shall be made only where approved by the Engineer.

### PLACING OF CONCRETE

Concrete which upon or before placing is found not to conform with the requirements specified herein shall be rejected and immediately removed from the work. Concrete which is not placed in accordance with these specifications, or which is of inferior quality, as determined by the engineer, shall be removed and replaced by and at the expense of the Contractor. No concrete shall be placed except in a present of duly authorized representative of the Engineer. Concrete shall not be placed when unsuitable heat or wind will prevent proper placement and curing, as determined by the Engineer,

Handwritten blue ink signature and initials.

prior to placing any concrete, the Contractor shall give the Engineer twenty four (24) hours written notice.

Concrete shall be deposited in its final position without segregation, re-handling, or flowing. Placing shall be done preferably with buggies, buckets, or wheel borrows. No chutes will be allowed except to transfer concrete from hoppers to buggies, wheel borrows, or buckets in which case, they shall not exceed six (6) meters (20') in aggregate length.

Placing of concrete with a free drop or fall more than 1.20m (4') shall not be allowed, except when approved by the Engineer and when approved sheet metal conduits, pipes or "elephant trunks" are employed. When employed, these conveyors shall be kept full of concrete and the ends kept buried in the newly placed concrete as pouring progresses.

Concrete in forms shall be deposited in uniform horizontal layers not deeper than 450mm (18") and care shall be taken to avoid inclined layers or inclined construction joints except where such care required for sloping members. Each layer shall be placed while the previous layer is still soft. The rate of placing concrete in forms shall not exceed 1.5 meters (5') of vertical rise per hour.

#### TAMPING AND VIBRATING

As concrete is placed in the forms or in excavations, it shall be thoroughly settled and compacted throughout the entire depth of the layer which is being consolidated, into a dense, homogeneous mass, filling all corners and angles, thoroughly embedding the reinforcement, eliminating rock pockets, and bringing only a slight excess of water to the exposed surface of concrete during placement.

Care shall be used in placing concrete around waterstops. The concrete shall be carefully worked by rodding and vibrating to make sure that all air and rock pockets have been eliminated. Where flat-strip type waterstops are used, the concrete shall be worked under the waterstops are used, the concrete shall be worked under the waterstops by hand making sure that all air and rock pockets have been eliminated.

Concrete in wall shall be internally vibrated and at the same time rammed, stirred, or worked with suitable appliances, tamping bars, shovels, or forked tools until it completely fills the forms or excavations and closes snugly against all surfaces. Subsequent layers previously placed have been worked thoroughly as specified. Except in special cases where their use is deemed impracticable by the Engineer, the Contractor shall use internally vibrated, high speed power vibrators not less than 8000 rpm of an approved immersion type in sufficient numbers, with standby units as required, to accomplish the results herein specified within fifteen (15) minutes after concrete of the prescribed consistency is placed in the forms. The vibrating head shall be kept from contact with the surfaces of the forms. Care shall be taken not to vibrate concrete excessively or to work it in any manner that causes segregation of its face.

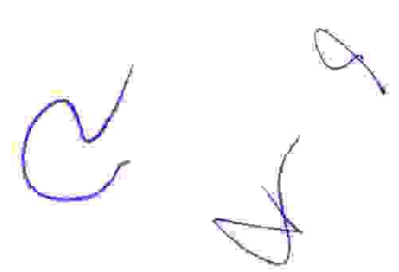



### CARE AND REPAIR OF CONCRETE

The Contractor shall protect all concrete against injury or damage from excessive heat, lack of moisture, over stress, or any other cause until final acceptance by the Owner. Particular care shall be taken to the drying of concrete and to avoid roughening or otherwise damaging the surface. Any concrete found to be damaged or which may have been originally defective at any time prior to the final acceptance of the complete work, or which departs from the established line or grade, or which for any other reason does not conform with the specifications shall be satisfactorily repaired or removed and replaced with acceptable concrete at the Contractor's expense.

### FINISH OF CONCRETE SURFACE

All finished or formed surfaces shall conform accurately with the shape, alignment, grades and sections as indicated on the plans or as prescribed by the Engineer. Surfaces shall be free from fins, bulges, ridges, offsets, honeycombing, or roughness of any kind, and shall present a finished, smooth, continuous hard surface.

Except as otherwise provided herein, unformed top surfaces of concrete shall be brought to uniform surfaces and worked with suitable tools to a reasonably smooth wood float finish. Excessive floating of surfaces while the concrete is plastic will not be permitted. All surfaces shall be placed monolithically with the base slab. Dusting of dry cement and sand on the concrete surface to absorb excess moisture will not be permitted. Floor slabs and exposed tops of walls and curbs shall be given a steel trowel finish. At the Contractor's option, the above mentioned floor slabs may be finished with a power float after screeding. Subsequent to the aforementioned finish, all sloping surfaces of floor slabs shall be lightly boomed to provide a skid resistant surface.

### TREATMENT OF SURFACE DEFECTS

As soon as forms are removed, all exposed surfaces shall be carefully examined and any irregularities shall be immediately rubbed or ground in a satisfactory manner in order to secure a smooth, uniform, and continuous surface. Plastering or coating of surfaces to be smoothed will not be permitted. No repairs shall be made until after inspection by the Engineer, and then only in strict accordance with his directions. Concrete containing voids, holes, honeycombing, similar depression defects shall be completely removed and replaced; provided that where required or approved by the Engineer, defects shall be repaired with gunite or with cement mortar placed by an approved compressed air mortar gun. In no case will extensive patching of honey combed concrete be permitted. All repairs and replacements herein specified shall be promptly executed by the Contractor at his own expense.

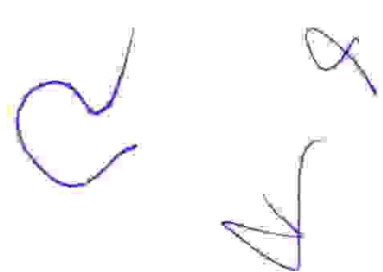

## DEPOSITING CONCRETE

### Depositing:

Depositing shall be done without segregation, remanding or flowing of concrete. It shall be done with the use of buggies, buckets or wheelbarrows. Use of chutes will not be allowed except to transfer concrete from hoppers to buggies, wheelbarrows or buckets in which case shall not exceed 20 feet in aggregate length placing of concrete with a free drop of fall of more than 5 feet are not allowed. Conveyors when used shall be kept full of concrete and ends shall be kept buried in the newly placed concrete as pouring progresses.

### Vibrations:

No placing of concrete will be allowed without vibrators. Segregation due to over vibration shall be avoided.

### Construction Joints:

If possible concreting shall be done continuous until section is complete. When stoppage of concrete operations occur, construction joints shall be placed either horizontally or vertically as indicated by the Engineer and provided with shear keys or dowels to develop bond. Construction joints shall be per plan or shall be approved or as directed by the Engineer.

## MEASUREMENT AND PAYMENTS

"Class A "concrete shall be measured by the cubic meter (cu.m.) of concrete completed in place and accepted.

Measurement will be of the actual number of cubic meter within the neat lines of the structure as shown in the plans or revised by authority of the Engineer. The volume of concrete measured as determined above shall be paid for at the contract unit price per cubic meter (cu.m.) which price and payment shall be full compensation mixing, placing, finishing and curing the concrete and all labor, equipment, tools and incidentals necessary to complete the item and accepted.

Payments for the reinforcement placed shall be included in the contract unit price per cubic meter (cu.m.) of concrete which price and payment shall be the full compensation of all labor, equipment, tools and incidentals necessary to complete the item and accepted.

Concrete forms placed shall be included in the contract unit price per cubic meter (cu.m.) of concrete which price and payment shall be the full compensation of all labor, equipment, tools and incidentals necessary to complete the item and accepted.

## TS - 07 CONCRETE MASONRY

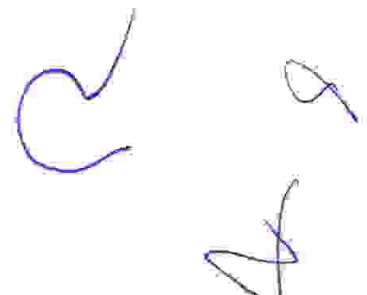

**General**

Concrete masonry construction shall include the furnishing of all labor, material, and equipment, and performing all operations necessary to execute all concrete masonry construction, as specified.

Contractor shall make all preparations and do all work necessary to receive and adjoin other work.

Contractor shall give the work his personal supervision and shall keep a competent foreman on the job at all times when he is not there himself.

Contractor shall specify the position of all dowels required for masonry on other construction, including foundations. Contractor shall arrange for the necessary storage space for construction materials at the jobsite.  
Contractor shall call for all inspections required in the course of his work by Owner.

**Materials****Concrete Hollow Blocks**

All property wall shall be 150mm thick x 200mm x 400mm non-bearing concrete hollow blocks, otherwise, use 100mm thick x 200mm x 400mm non-bearing concrete hollow blocks

**Mortar / Grout**

Mortar/grout shall be a mixture of 1 part cement and 3 parts fine sand

**Reinforcing Steel**

Reinforcing steel shall be 10mm diameter, Grade 40, spaced at 600mm on-center along horizontal and vertical of the walls. Reinforcement shall be secure with a Ga. 16 tie wire.

**Masonry Construction**

Blocks shall be cut accurately to fit all plumbing ducts, openings, electrical work, and all voids shall be flushed full. Where walls are to receive plaster, the joints should be struck flush. Where certain joints are to be concealed under paint, these joints shall be filled flush and then sanded to produce a dense surface without sheen.

Vertical head joints shall be buttered well for a thickness equal to the face shell of the block and these joints shall be shoved tightly so that the mortar bonds well to both blocks. Joints shall be solidly filled from the face of the block to the depth of the face shell.

**Grouting**

Reinforcing steel shall be in place and inspected before grouting starts. Vertical cells to be filled with mortar shall have vertical alignment to maintain a continuous



unobstructed cell area. Cells containing reinforcement shall be solidly filled with grout.

## Plastering

### Mixture

Mortar mixture for brown coat shall be freshly prepared and uniformly mixed in the proportion by volume of one part Portland Cement, three (3) parts sand.

- a) Finish coat shall be pure Portland Cement properly graded. Hydraulic Cement and mixed with water to approved consistency and plasticity.

### Surface Preparation

- a) After removals of formworks reinforce concrete surfaces shall be roughened to improve adhesion of cement plaster.
- b) Surfaces to receive cement plaster shall be cleaned of all projections, dust, loose particles, grease and bond breakers. Before any application of brown coat is commenced all surfaces that are to be plastered shall be wetted thoroughly with clean water to produce a uniformly moist condition.

### Application

- a) Brown coat mortar mix shall be applied with sufficient pressure starting from the lower portion of the surface to fill the grooved and to prevent air pockets in the reinforced concrete/masonry work and avoid mortar mix drooping. The brown coat shall be lightly broomed/ or scratch before surface had properly set and allowed to cure.
- b) Finish coat shall not be applied until after the brown coat has seasoned for seven days and corrective measures had been done by the Contractor on surfaces that are defective. Just before the application of the finish coat, the brown coat surface shall be evenly moistened with potable water. Finish coat shall be floated first to a true and even surface, then troweled in a manner that will force the mixture to penetrate into the brown coat. Surfaces applied with finish coat shall then be smooth with paper in a circular motion to remove trowel marks, checks and blemishes. All cement plaster finish shall be 10 mm thick minimum on vertical concrete and/or masonry walls.

### Workmanship

Cement plaster finish shall be true to details and plumbed. Finish surface shall have no visible junction marks where one (1) Day's work adjoins the

other. Where directed by the NPC or as shown on the Plans vertical and horizontal groove joints shall be 25 mm wide and 10 mm deep.

### **MEASUREMENT AND PAYMENT**

Measurement and payment shall be made at the contract unit price or lot price as specified in the Bid Price Schedule. Payment shall include all cost in furnishing labor, materials, tools equipments and other incidentals necessary for the satisfactory completion of the project.

### **TS – 08 ROOF FRAMING (WELDING AND STEEL WORKS)**

#### **General**

The work to be executed under this section shall include the furnishing of all, labor, tools, equipment and other facilities necessary for the satisfactory performance of all work necessary to complete all demolition and disposal works.

#### **Work Included**

- a) The work included under this section shall include the furnishing, fabrication, erection and/or installation of all steel roof framing, steel girts and other work indicated in the Plans and Specifications.

#### **Materials**

- a) All G. I. pipes shall be schedule 40 unless otherwise noted in the Plans.
- b) Rectangular tube and C-Purlins shall have a 1.00mm thickness
- c) Angle bars and flat bars shall have a thickness of 3/16"
- d) All arc-welding electrodes shall conform to the requirements of the American Welding Society "SPECIFICATIONS FOR IRON AND STEEL ARC- WELDING ELECTRODES" latest edition

#### **Connections**

- a) Shop connections shall be welded unless otherwise indicated in the Plans. All connections shall develop full strength of members.

#### **Workmanship and Fabrication**

- a) Workmanship and fabrication shall be in accordance with AISC "Specification for Fabrication and Erection of Structural steel for Buildings" and with the following outline.
- b) Bearing surfaces shall be planed to true beds. Abutting surfaces shall be closely fitted
- c) All columns and bearing stiffeners shall be milled to give full bearing over the cross section. It shall not be necessary to plane bottom surfaces of plate on grout beds.
- d) Assembled parts shall be brought into close contact, and drift pin shall be used only for bringing members into position, not to enlarge or distort holes.

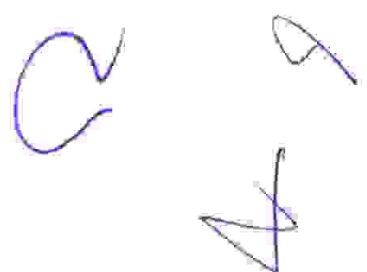

**Welding**

- a) Welding in shop and field shall be done by qualified welders. Equipment shall be of the type, which produce proper current so that operator may produce satisfactory welds. The welding machine shall be of 300 amperes, 200 -240 volts capacity.
- b) Unless otherwise shown on the Plans, the following low hydrogen electrodes shall be used and shall be suitable for positions and other conditions of intended use in accordance with the instruction with each container.

<u>Welding</u>	<u>Electrode</u>	<u>Submerged Arc Process</u>
A-7 to A-7	E - 60 Series	Grade SAW-2
A-7 to A-36	E - 70 Series	Grade SAW-2
A-36 to A-36	E - 70 Series	Grade SAW-2

- c) The technique of welding employed, the appearance and quality of welds made, and the methods of correcting defective work shall conform to the American Welding society code for arc welding. Surfaces to be welded shall be free from loose scale, rust, grease, paint and other foreign material except that mill scale, which withstands vigorous wire brushing, may remain
- d) Finish members shall be true to line and free from twists, bends and open joints.

**Measurement and Payment**

Measurement and payment shall be made at the contract unit price or lot price of the various applicable items specified in the Bid Price Schedule. Payment shall include all cost in furnishing labor, materials, equipments and other incidentals necessary for the satisfactory completion of the project.

**TS – 09 ROOFING WORKS AND SIDING SHEETS**

**General**

The contractor shall furnish all labor, materials and operations including tools, other implements and accessories for the complete installation of roofing sheets wherever indicated in the drawings.



Installation shall be performed by skilled workmen in accordance with the construction and shop drawings and the manufacturer's standard.

Shop drawings and manufacturer's catalogue showing product standards and technical data will be provided by the Contractor to the NPC representative for approval.

### **Materials**

Material for roofing shall be weather and chemical resistant. It shall be corrugated aluminum-zinc-silicon alloy coated metal sheet. Base metal shall be determined as specified in the drawing that shall range from 0.4 to 0.60mm thick. Branded sheets such as flat barge caps, flashings, ridge rolls, capping and mouldings that serve as its accessory components shall have the same composition with the roofing and sidings of which minimum thickness base metal shall be 0.5mm. Gutters likewise shall have the same material composition with base metal thickness of 0.50mm unless otherwise specified in the drawing commonly as stainless.

### **Workmanship**

Roofing and siding sheets shall be securely fastened on purlins and channels by hook or stove bolts or self-drilling screws or as required. Fasteners shall have a maximum distance of 0.30m O.C. along purlins.

Special care shall be given to the joints, lapping, bolting and setting of closers.

### **Measurement and Payment**

Measurement and payment for Roofing Works and Siding Sheets will be based on the projected area inspected and accepted by the NPC Representative. No measurement & payment will be made on hidden areas covered by side & end overlaps, the cost for these being included in the projected area.

Payment will be made at the corresponding unit price per square meter including ridge roll, flashing, capping for pertinent items in the Bill of Quantities

## **TS-10 ELECTRICAL WORKS**

### **Work Included**

The work included under this section shall include the furnishing, fabrication, erection and/or installation of electrical system and other steel work indicated in the Plans and Specifications.

### **Standard of Materials**

All materials to be used in the work shall be new, of high quality, free from all defects and of proven acceptability from the purpose of intended. Unless otherwise specified, materials shall conform to the latest applicable standard issued by the following authorities:

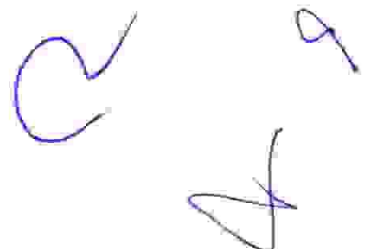

- a) American National Standards Institute (ANSI)
- b) Institute of Electrical and Electronic Engineers (IEEE)
- c) Underwriter's Laboratory (UL)
- d) National Electrical Manufacturers Association (NEMA)
- e) National Electrical Code (NEC)
- f) Philippine Electrical Code (PEC)

Other recognized national standards maybe accepted if, in the opinion of NPC representatives, such will guarantee a quality not inferior to that guaranteed by the above standards.

In case of conflicting requirements between authorities cited above and those specified, such disagreement shall be resolved by representative of which his decision shall be final.

### Lighting System

The lighting system covered by this specification includes associated conduits and cables, lighting fixtures, fittings, etc.

The device/materials furnished shall be in accordance with, but not limited to, the latest issues of the Applicable Codes and Standards, including all addenda, in effect at time of purchase order unless otherwise stated in this Specification.

All materials and parts which are not specifically mentioned herein but are necessary for the proper installation and safe operation of the lighting system shall be identified by the Contractor and shall be furnished at no additional cost to NPC.

### Lighting Fixtures and Accessories

#### Street Lighting Fixtures

All lighting fixtures when installed shall be free of leaks, warps, dents and other irregularities.

All lighting fixtures, samples and catalogues shall be submitted for NPC's review and approval prior to the order. No lighting fixtures shall be installed without the approval of NPC.

Lighting fixtures shall be wired with approved wire, 75°C insulation. Each fixture shall be wired to a single point with an adequate slack for proper connection. All lighting fixture shall be protected from damage during installation. Any broken lighting fixtures, receptacle, stem and the like shall be replaced with new parts, at no cost to NPC.

### Cables / Wires

Cable shall be stranded annealed copper conductor suitable for continuous temperature of 90°C when used in wet or dry location and 90°C when exposed to oil or coolant. The minimum size of conductor to be used shall be 5.5mm<sup>2</sup>

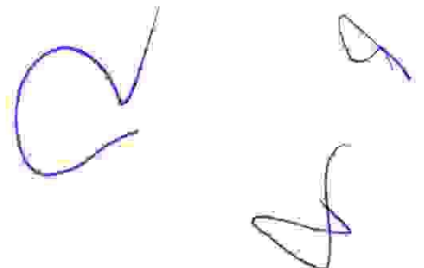

The cables shall be designed for trouble free service for the highest system voltage. All cables and their accessories to be supplied shall have insulation levels able to withstand any voltage surges which are normally expected to occur in the power system in which are normally expected to occur in the power system in which the cable is to be employed, due to switching operations, sudden load variation, faults, etc.

The cables and accessories shall be constructed to fulfill the requirements when operating with full load or any load factor and is suitable for use in ducts, trays and or direct burial in ground.

### **Cables Installation**

Cable pulled through conduit shall be supported in an approved manner so as to avoid damaged to the insulation. Grease or oily substances shall not be used to facilitate the passage of the conductor in conduits.

The pull shall be applied to cables only by means of approved grips and the end portion of the cable which has been marked or deformed by the grip shall be cut-off by the Contractor.

All cable runs shall be continuous and all termination shall be at the terminal boards, equipment, etc. No splices are allowed in conduit or cable tray.

Prior to installation of cables, conduits shall be thoroughly cleaned to prevent damage to cables during installation. After cables have been installed, cables shall be tested for continuity and insulation resistance and shall be tagged with respective cable number

### **Conduits**

All conduits, boxes and fittings required for the power and control conductors including necessary hardware and accessories such as screws, bolts, concrete inserts, clamps, locknuts, couplings shall be furnished by the Contractor. The required quantities shall be furnished in accordance with the installation requirements.

During installation, due precaution shall be taken to protect the conduit and threads from mechanical injury. The ends of the conduit shall be sealed in an approved manner. Conduit runs shall be sealed by the use of caps and discs or plugs. The seals shall be maintained, except during inspection and tests, until the conductor is pulled in. Conduit shall be check to be free from obstructions by pulling a wooden mandrel of appropriate size through the conduit.

Conduits installed outdoors running underground shall be buried to a minimum of 0.457 m.

### **Measurement and Payment**

Measurement and payment shall be made at the contract unit price or lot price of the various applicable items specified in the Bid Price Schedule. Payment shall include all cost in furnishing labor, materials, equipment and other incidentals necessary for the satisfactory completion of the project.





**General**

The work to be executed under this section shall include the furnishing of all, labor, tools and ladders, scaffolding and other facilities necessary for the satisfactory performance of all work necessary to complete the works specified in this specifications.

**Material**

Materials to be used shall be the following but not limited to:

1. Double Furring
2. Wall Angle
3. 1/4" thick Fiber Cement Board
4. Blind Rivets

**Workmanship**

All work shall be done by skilled workers in a workmanlike manner.

Wall angles shall be firmly secured at the walls of the building through nails. All double furring shall be installed firmly and aligned. Nylon or string connected wall to wall shall be used so that correct level of furring will be attained. Fiber cement board shall be installed and secured on the furring through rivets or screws.

**MEASUREMENT AND PAYMENT**

Measurement and payment shall be made at the contract unit price or lot price as specified in the Bid Price Schedule. Payment shall include all cost in furnishing labor, materials, tools equipment and other incidentals necessary for the satisfactory completion of the project.

**TS -12 PAINTING, VARNISHING AND OTHER RELATED WORKS****General**

This Item shall consist of furnishing all paint materials, varnish and other related products, labor, tools, equipment and plant required in undertaking the proper application of painting, varnishing and related works indicated on the Plans and in accordance with this Specification.

**Material Requirements**

1. Top Coat, Liquid Tile or approved equivalent
2. Primer, Liquid Tile or approved equivalent
3. Tile Cast
4. Liquid Tile Reducer
5. Brush and Roller

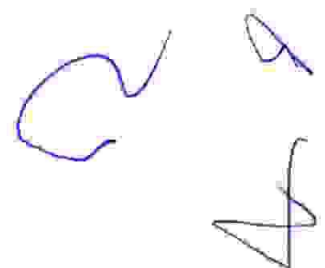

**Paint Materials**

All types of paint material, varnish and other related product shall be subject to random inspection by NPC Inspector or GSFM (Use the following approved and tested brand name: Boysen, Davies, Dutch Boy, Fuller O Brien, or any approved equal).

**Tinting Colors**

Tinting colors shall be first grade quality, pigment ground in alkyd resin that disperses and mixes easily with paint to produce the color desired. Use the same brand of paint and tinting color to effect good paint body.

**Concrete Neutralizer**

Concrete neutralizer shall be first grade quality concentrate diluted with clean water and applied as surface conditioner of new interior and exterior walls thus improving paint adhesion and durability.

**Silicon Water Repellant**

Silicon water repellant shall be transparent water shield especially formulated to repel rain and moisture on exterior masonry surfaces.

**Patching Compound**

Patching compound shall be fine powder type material like calcimine that can be mixed into putty consistency, with oil base primers and paints or pre-mix glazing putty, tile cast to fill minor surface dents and imperfections whichever is applicable.

**Varnish**

Varnish shall be a homogeneous solution of resin, drying oil, drier and solvent. It shall be extremely durable clear coating, highly resistant to wear and tear without cracking, peeling, whitening, spotting, etc. with minimum loss of gloss for a maximum period of time.

**Lacquer**

Lacquer shall be any type of organic coating that dries rapidly and solely by evaporation of the solvent. Typical solvent are acetates, alcohols and ketones. Although lacquers were generally based on nitrocellulose, manufacturers currently use, vinyl resins, plasticizers and reacted drying oils to improve adhesion and elasticity.

**Sanding Sealer**

Sanding sealer shall be quick drying lacquer, formulated to provide quick dry, good holdout of succeeding coats, and containing sanding agents such as zinc stearate to allow dry sanding of sealer.

**Construction Requirements**

The Contractor prior to commencement of the painting, varnishing and related work shall examine the surfaces to be applied in order not to jeopardize the quality and appearances of the painting varnishing and related works.

### Surface Preparation

All surfaces shall be in proper condition to receive the finish. Woodworks shall be hand-sanded smooth and dusted clean. All knotholes pitch pockets or sappy portions shall be sealed with natural wood filler. Nail holes, cracks or defects shall be carefully puttied after the first coat, matching the color of paint.

Interior woodworks shall be sandpapered between coats. Cracks, holes of imperfections in plaster shall be filled with patching compound and smoothed off to match adjoining surfaces.

Concrete and masonry surfaces shall be coated with concrete neutralizer and allowed to dry before any painting primer coat is applied. When surface is dried apply first coating. Hairline cracks and unevenness shall be patched and sealed with approved putty or patching compound.

After all defects are corrected apply the finish coats as specified on the Plans (color scheme approved).

Metal shall be clean, dry and free from mill scale and rust. Remove all grease and oil from surfaces. Wash unprimed galvanized metal with etching solution and allow it to dry. Where required to prime coat surface with Red Lead Primer same shall be approved by the NPC Engineer.

In addition the Contractor shall undertake the following:

1. Voids, cracks, nick etc. will be repaired with proper patching material and finished flush with surrounding surfaces.
2. Marred or damaged shop coats on metal shall be spot primed with appropriate metal primer.
3. Painting and varnishing works shall not be commenced when it is too hot or cold.
4. Allow appropriate ventilation during application and drying period.
5. All hardware will be fitted and removed or protected prior to painting and varnishing works.

### Application

Paints when applied by brush shall become non-fluid, thick enough to lay down as adequate film of wet paint. Brush marks shall flay out after application of paint.

Paints made for application by roller must be similar to brushing paint. It must be nonstick when thinned to spraying viscosity so that it will break up easily into droplets.

Paint is atomized by high pressure pumping rather than broken up by the large volume of air mixed with it. These procedures change the required properties of the paint.

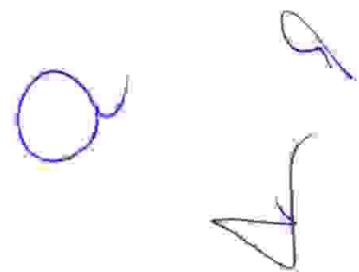



### Mixing and Thinning

At the time of application paint shall show no sign of deterioration. Paint shall be thoroughly stirred, strained and kept at a uniform consistency during application. Paints of different manufacture shall not be mixed together. When thinning is necessary, this may be done immediately prior to application in accordance with the manufacturer's directions, but not in excess of 1 pint of suitable thinner per gallon of the paint.

### Storage

All material to be used under this item shall be stored in a single place to be designated by the Engineer and such place shall be kept neat and clean at all time. Necessary precaution to avoid fire must be observed by removing oily rags, waste, etc. at the end of daily work.

### Cleaning

All cloths and cotton waste which constitute fire hazards shall be placed in metal containers or destroyed at the end of daily works. Upon completion of the work, all staging, scaffolding and paint containers shall be removed. Paint drips, oil, or stains on adjacent surfaces shall be removed and the entire job left clean and acceptable to the Engineer.

### Workmanship in General

- a) All paints shall be evenly applied. Coats shall be of proper consistency and well brushed out so as to show a minimum of brush marks.
- b) All coats shall be thoroughly dry before the succeeding coat is applied.
- c) Where surfaces are not fully covered or cannot be satisfactorily finished in the number of coats specified such preparatory coats and subsequent coats as may be required shall be applied to attain the desired evenness of surface without extra cost to the owner.
- d) Where surface is not in proper condition to receive the coat the Engineer shall be notified immediately. Work on the questioned portion(s) shall not start until clearance be proceed is ordered by the NPC Engineer.
- e) Hardware, lighting fixture and other similar items shall be removed or protected during the painting varnishing and related work operations and re-installed after completion of the work.

### MEASUREMENT AND PAYMENT

Painting and/or varnishing shall be measured in square meter (sq.m.) of painting completed in place and accepted. Measurement will be of the actual number of square meter within the neatlines of the structure as shown in the plans or revised by authority of the NPC Engineer. The area of painting measured as determined above shall be paid for at the contract unit price per square meter (sq.m.) which price and payment shall be full compensation of all labor, equipment, tools and incidentals necessary to complete the item and accepted.

### TS- 13 CLEARING AND DEMOBILIZATION

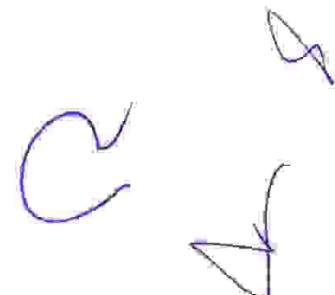

Before moving out, the contractor shall restore the orderly state of worksite by clearing all temporary structures. Remove all excess/waste materials and store in designated areas.

Before the Contractor will demobilize its construction equipment/ tools, materials and crew, he shall secure approval from NPC security office for the release of the contractor's equipment and to surrender the workers Identification (I.D) cards. A joint inspection with the NPC inspector and Contractor will be conducted to make sure that all his accomplishment / work that needs remedial attention or correction shall be done prior to the issuance of the Certificate of Completion. The Certificate of Completion will serve as basis for the processing of payments.

Handwritten signature and initials in blue ink, consisting of a large 'C' and a smaller 'A' with a checkmark-like flourish.



## ***Section VII. Drawings***

**Sheet No. 1/5–VICINITY MAP/LOCATION PLAN / PERSPECTIVE**

**Sheet No. 2/5– PEDESTAL, CYLINDRICAL TANK, ANCHOR BOLT DETAILS**

**Sheet No. 3/5–FOUNDATION PLAN, SECONDARY CONTAINMENT PLAN,  
OIL&STORM WATER TRAP SECTION DETAILS**

**Sheet No. 4/5–FRONT, REAR ELEVATION & SECTION**

**Sheet No. 5/5–ROOF DETAILS, ROOF SEQUENCE**

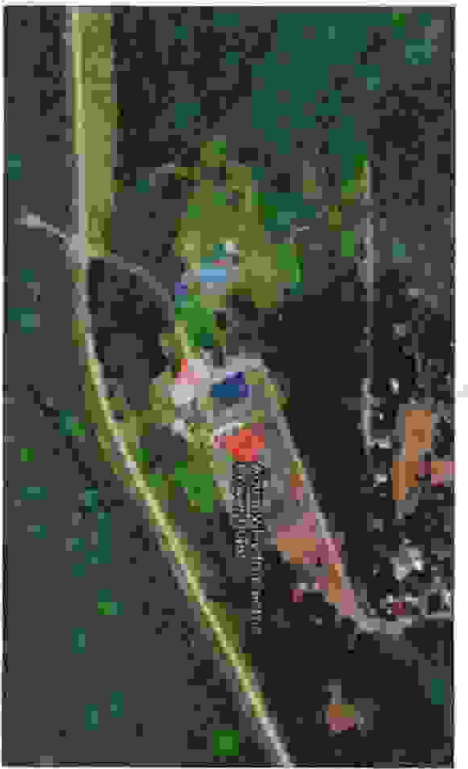

○ VICINITY MAP

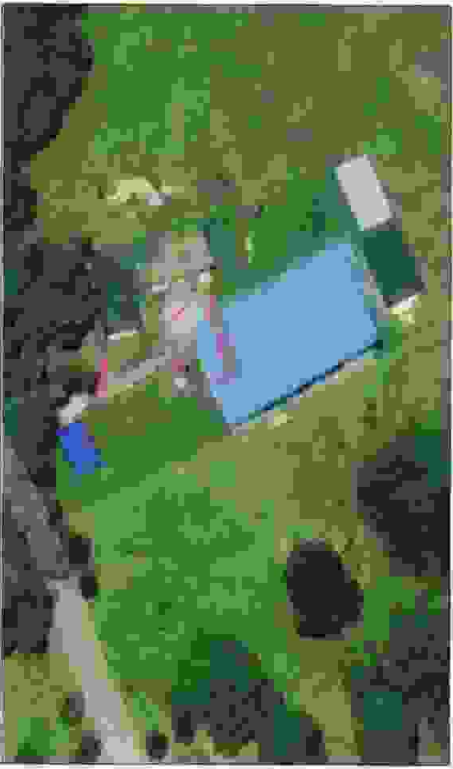

○ LOCATION MAP

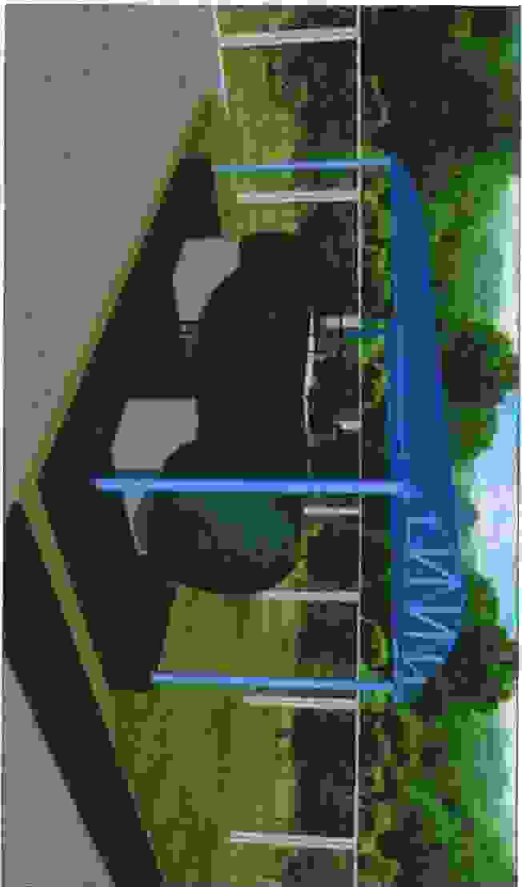

○ PERSPECTIVE



**NATIONAL POWER CORPORATION**  
Mindanao Generation  
**AGUS 5 HEP**

PREPARED BY: **G. N. ALAMAG** (Signature)  
Submitted: **10/11/2011**  
SUBMITTED BY: **G. V. ALAMAG** (Signature)  
Checked: **10/11/2011**

RECOMMENDED BY: **N. A. BELANDIA** (Signature)  
Checked: **10/11/2011**  
APPROVED BY: **E. A. VELASCO, JR.** (Signature)  
Checked: **10/11/2011**  
Via President, Mindanao Generation

PROJECT		AGUS 4 INST. OF CYLINDRICAL TANK FOR HYDROTOR USED OIL		SHEET NO.
LOCATION				
DESIGNED	BY	CHKD.	DATE	PARTICULARS
DRAWN				<b>1</b>
REVIEWED				
CIVIL/ARCH'T				
ELECO				
MECH.				<b>5</b>

DWG

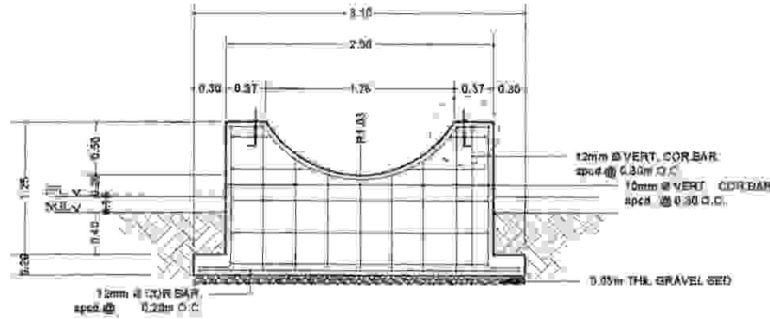

PEDESTAL DET.

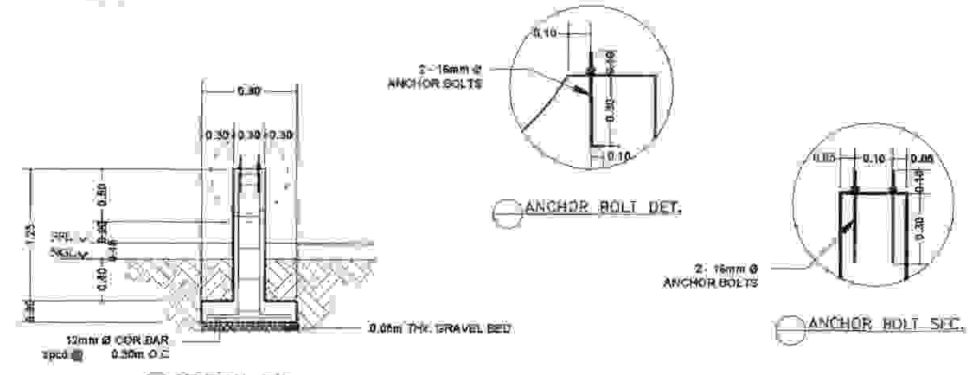

PEDESTAL SEC.

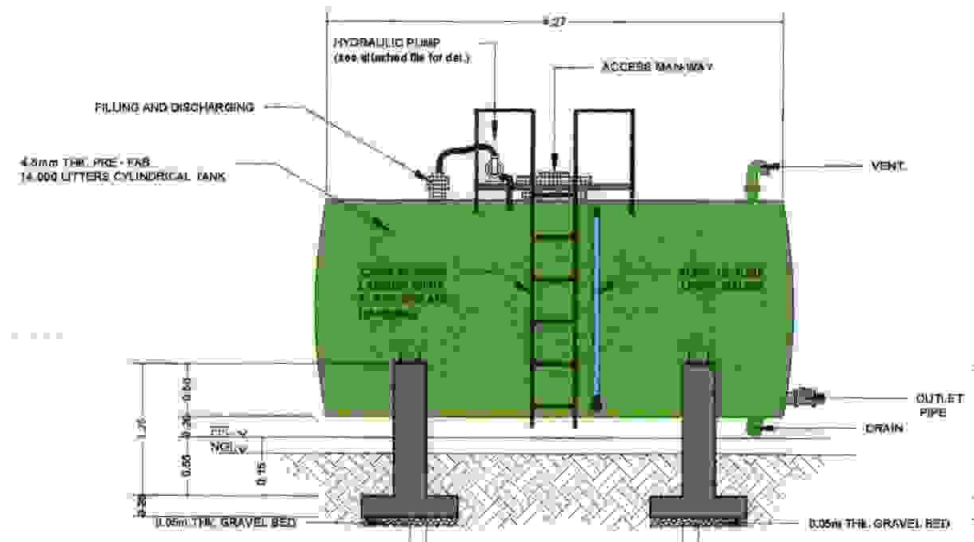

CYLINDRICAL TANK DET.

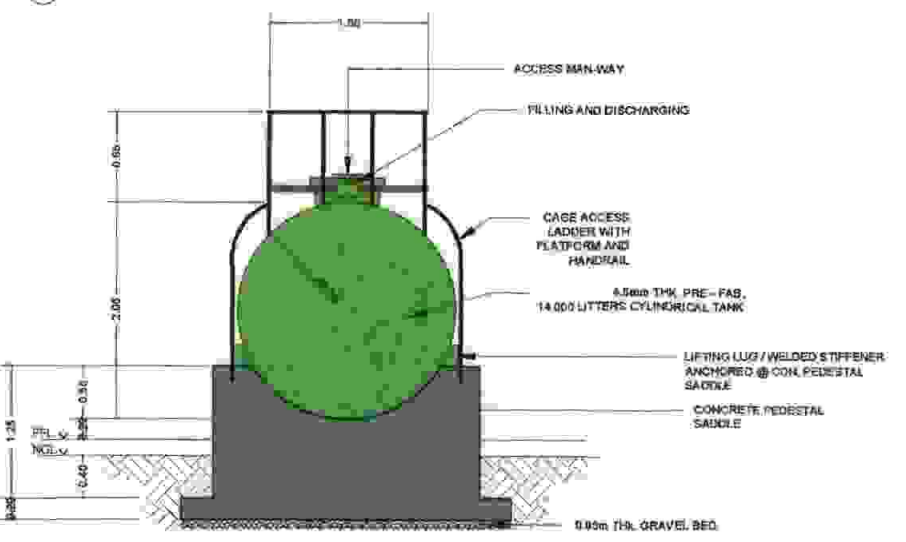

CYLINDRICAL TANK SECTION DET.



**NATIONAL POWER CORPORATION**  
Mindanao Generation  
**AGUS 5 HEP**

PROJECT: **AGUS 4 INST. OF CYLINDRICAL TANK FOR HYDROTOR USED OIL**

SHEET NO.

LOCATION:

	BY	CHKD	DATE	PARTICULARS
DESIGNED				
DRAWN				
REVIEWED	PRINCIPAL ENGR. / ARCHT			
CIVIL / ARCHT				
ELEC.				
MECH.				

**2**

**5**

DWG

PREPARED

**L.G. NAYONS**  
Manufacturing Supervisor

SUBMITTED:

**C.V.L. ALAMAG**  
Plant OM Manager, Agus 4 HEP

RECOMMENDED

**N.T. BENIGRA**  
Plant Manager, Agus 4 & 5 HEP

APPROVED:

**E.A. VELOSO JR.**  
Vice President, Mindanao Generation

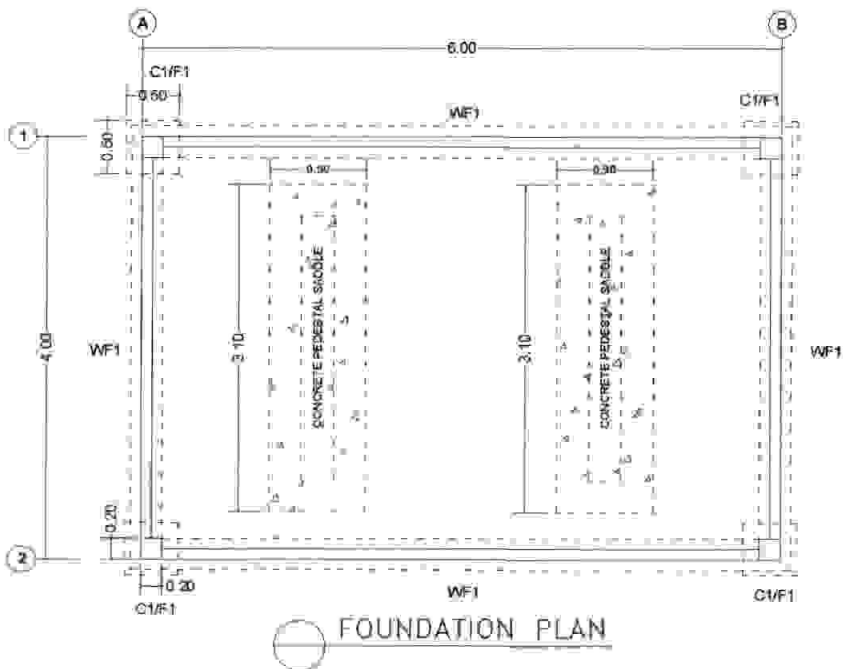

FOUNDATION PLAN

NOTE:

The SECONDARY CONTAINMENT Must have a sufficient capacity to contain ~~not less than 10%~~ <sup>at least 10%</sup> of the tank's volume.

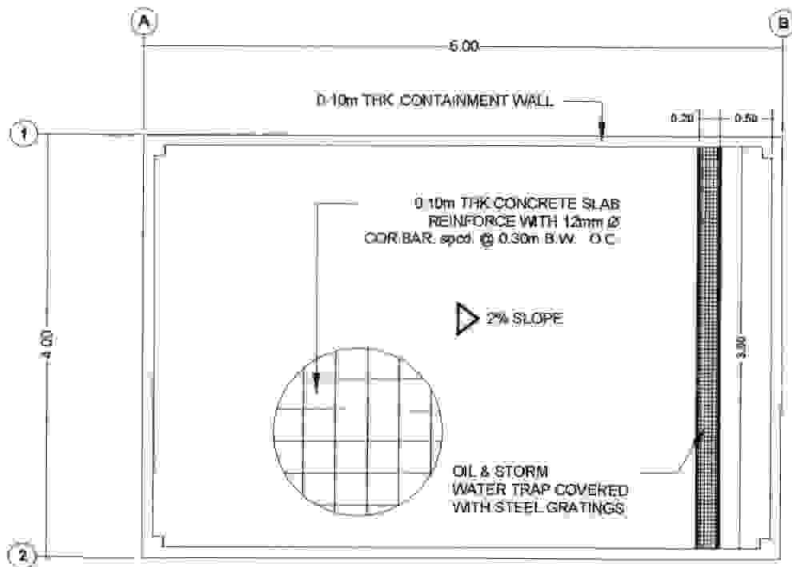

SECONDARY CONTAINMENT PLAN

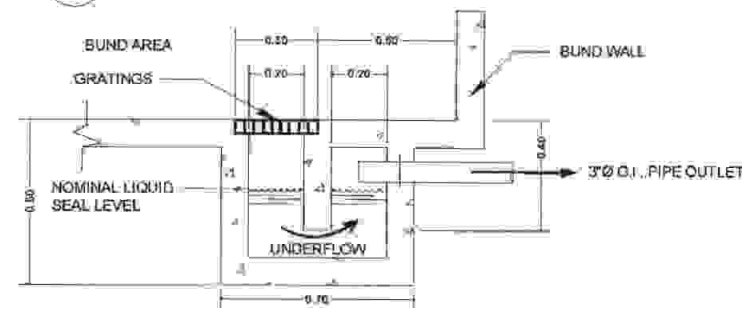

OIL & STORM WATER TRAP SECTION DET.



**NATIONAL POWER CORPORATION**  
Mindanao Generation  
AGUS 5 HEP

PROJECT: **AGUS 4 INST. OF CYLINDRICAL TANK FOR HYDROTOR USED OIL**

SHEET NO.

LOCATION

	BY	CHKD	DATE	PARTICULARS
DESIGNED				
DRAWN				
REVIEWED	PRINCIPAL ENGR / ARCHT.			
CIVIL / ARCH T				
ELEC				
MECH.				

**3**

**5**

DWG

PREPARED

**L.S. NANGSAP**  
Asst. Project Mgr. Agus 4 & 5 HEP

SUBMITTED:

**C.V.L. ALAMAG**  
Prinl. Engr. Manager, Agus 5 HEP

RECOMMENDED

**N.T. BENIGRA**  
Chief Manager, Agus 4 & 5 HEP

APPROVED:

**E.A. VELOSO JR.**  
Vice President, Mindanao Generation

06-01-22

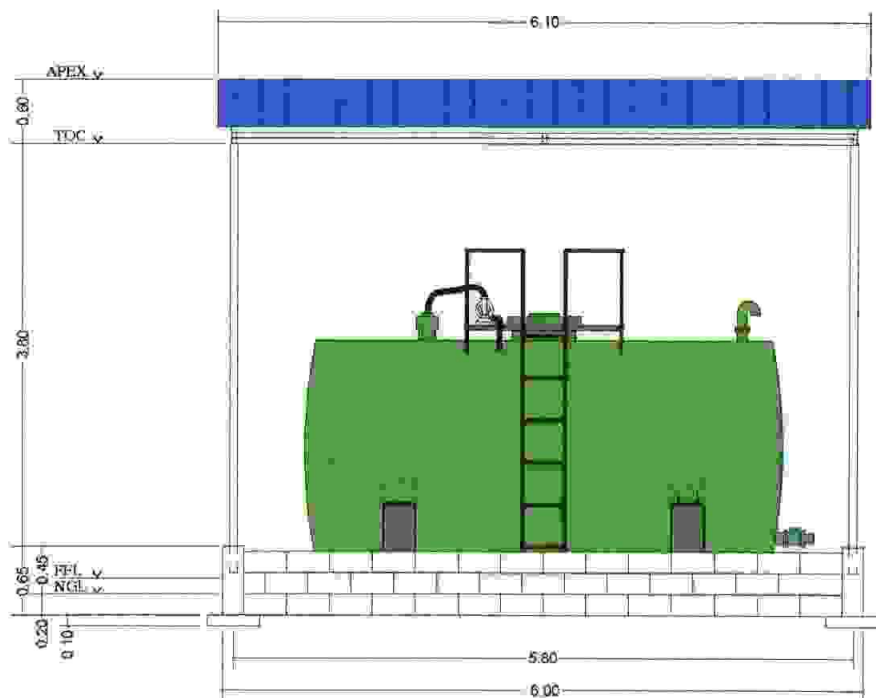

○ FRONT / REAR ELEVATION

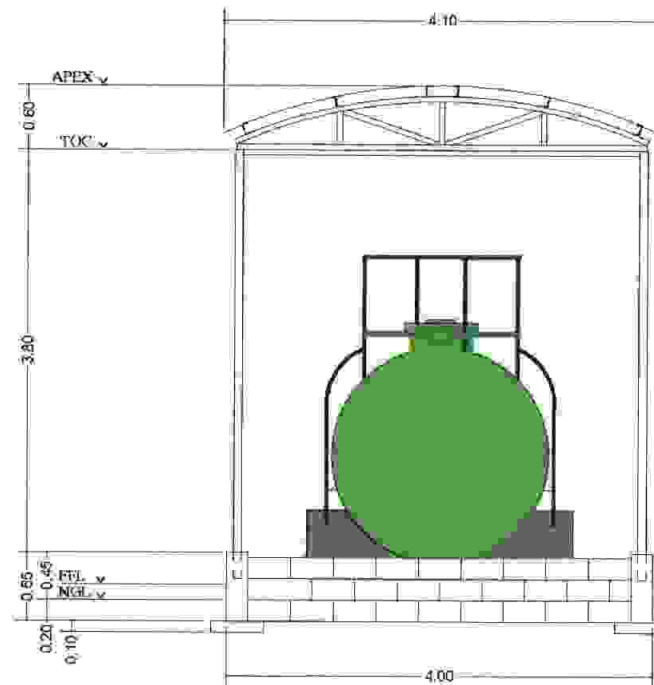

○ SECTION



**NATIONAL POWER CORPORATION**  
Mindanao Generation  
AGUS 5 HEP

PROJECT:

**AGUS 4 INST. OF CYLINDRICAL  
TANK FOR HYDROTOR USED OIL**

SHEET NO.

LOCATION

	BY	CHKD	DATE	PARTICULARS
DESIGNED				
DRAWN				
REVIEWED	PRINCIPAL ENGR. / ARCH'T.			
CIVIL / ARCH'T				
ELEC.				
MECH.				

PREPARED

**L.G. NANGGAS**  
Plant Manager, Agus 4 & 5 HEP

SUBMITTED

**C.V.L. ALAMAG**  
Plant O/M Manager, Agus 4 HEP

RECOMMENDED

**N.T. BENIGRA**  
Plant Manager, Agus 4 & 5 HEP

APPROVED

**E.A. VELOSO JR.**  
Vice President, Mindanao Generation

**4**

**5**

DWG

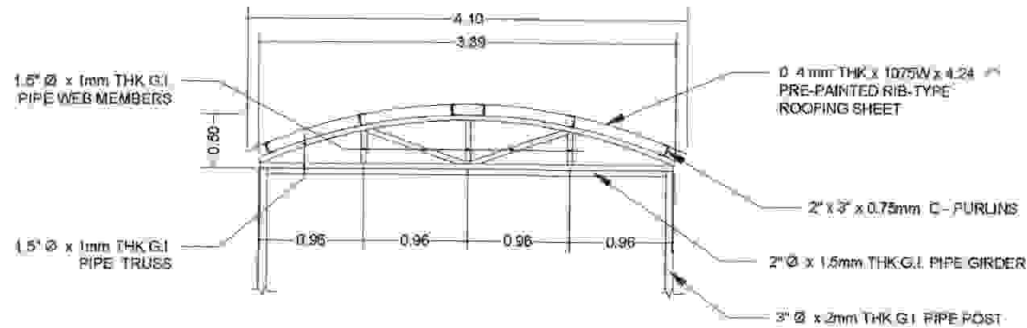

ROOF DETAIL

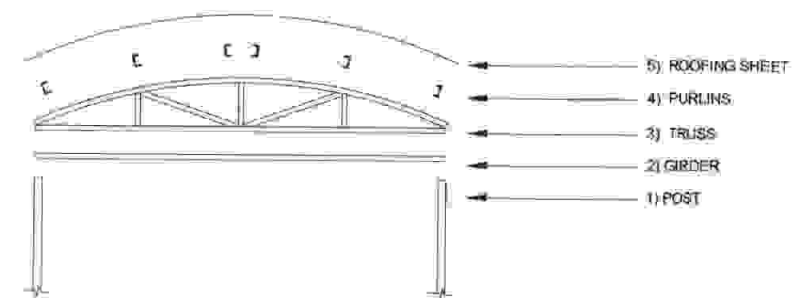

ROOF SEQUENCE

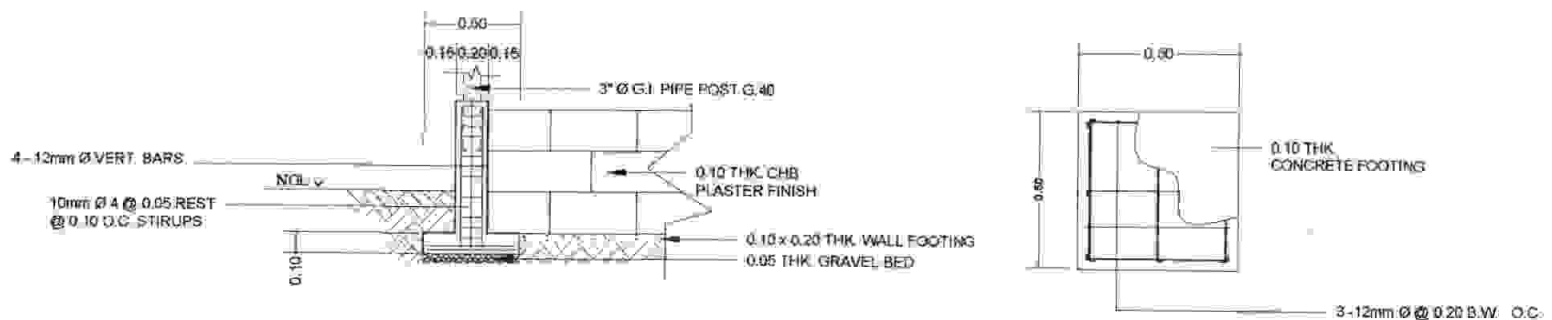

C1 / F1 DET.

**NATIONAL POWER CORPORATION**  
Mindanao Generation  
**AGUS 5 HEP**

PREPARED: **I.G. NARVES**  
Main Foreman, Agus 4 HEP

SUBMITTED: **C.V.L. ALMAG**  
Chief-OM Manager, Agus 4 HEP

RECOMMENDED: **N.Y. BEUGRA**  
Plant Manager, Agus 4 & 5 HEP

APPROVED: **E.A. VELOSO JR.**  
Vice President, Mindanao Generation

PROJECT		<b>AGUS 4 INST. OF CYLINDRICAL TANK FOR HYDROTOR USED OIL</b>			SHEET NO.
LOCATION					
	BY	CHKD	DATE	PARTICULARS	<b>5</b> <b>5</b>
DESIGNED					
DRAWN					
REVIEWED	PRINCIPAL ENGR / ARCHT.				
CIVIL / ARCHT					
ELEC.					
MECH					DWG

## *Section VIII. Bill of Quantities*

SECTION VIII - BILL OF QUANTITIES

**BILL OF QUANTITIES**

Item No.	Description of Work or Materials	Estimated Quantity	Unit	Unit Price in Pesos (Words and Figures)
1	PURCHASE OF FABRICATED CYLINDRICAL TANK (14,000 L)	1	lot	_____
2	SITE WORKS	1	lot	_____
3	LAY-OUT AND STAKING	1	lot	_____
4	EXCAVATION	4.65	cu.m	_____



5	EMBANKMENT WORKS	5	cu.m
6	REINFORCED CONCRETE WORKS	3.22	cu.m.
7	MASONRY WORKS	12	sq.m.
8	STEEL STRUCTURE	1	lot
9	ROOFING WORKS	1	lot

---

---

---

---

---

BID DOCUMENTS

NAME OF PROJECT: INSTALLATION OF CYLINDRICAL TANK  
FOR HYDROTOR USED OIL  
PR NO /REF NO: MG-A5M22-165/INFRA2022-AG5-052

**10 MECHANICAL WORKS 1 lot**

\_\_\_\_\_

**11 ELECTRICAL WORKS 1 lot**

\_\_\_\_\_

**12 PAINTING WORKS 1 lot**

\_\_\_\_\_

\_\_\_\_\_  
Name of Firm

\_\_\_\_\_  
Name and Signature of Authorized Representative

BID DOCUMENTS

NAME OF PROJECT INSTALLATION OF CYLINDRICAL  
HYDRATOR TANK FOR USED OIL

SECTION IX- CHECKLIST OF TECHNICAL &  
FINANCIAL DOCUMENTS

PR NO./REF NO MG-A5M22-165INFRA2022-AG5-052

## ***Section IX. Checklist of Technical and Financial Documents***

## Checklist of Technical and Financial Documents

### I. TECHNICAL COMPONENT ENVELOPE/Submit in three (3) copies- one (1) marked Original with the understanding that the Pass/Fail evaluation will be based only on the copy marked "Original"]

#### Class "A" Documents

##### Legal Documents

- (a) Valid and updated PhilGEPS Registration Certificate (Platinum Membership) (all pages) **in accordance with Section 8.5.2 of the IRR; or**

##### Technical Documents

- (b) Statement of the prospective bidder of all its ongoing government and private contracts, including contracts awarded but not yet started, if any, whether similar or not similar in nature and complexity to the contract to be bid, *using NPC-MinGen Standard Form No. NPCMGNSF-INFR-01; and*
- (c) Statement of the bidder's Single Largest Completed Contract (SLCC) similar to the contract to be bid, except under conditions provided under the rules, *using NPC-MinGen Standard Form No. NPCMGNSF-INFR-02 supported with the following documents:*
- *Contract and/or Notice to Proceed;*
  - *For project completed less than one year from the scheduled date of bid opening, submit Certificate of Completion;*
  - *For project completed at least one year from the scheduled date of bid opening, submit Owner's Certificate of Final Acceptance issued by the project owner other than the contractor, or a final rating of at least Satisfactory in the Constructor's Performance Evaluation System (CPES);*
  - *In case of contracts with the private sector, an equivalent document (Ex. Official receipt) shall be submitted.*
- and**
- (d) Special PCAB License in case of Joint Ventures;
- and** registration for the type and cost of the contract to be bid; **and**
- (e) Original copy of Bid Security. If in the form of a Surety Bond, *using NPC-MinGen Standard Form No. NPCMGNSF-INFR-03a*, submit also a certification issued by the Insurance Commission;
- or**
- Original copy of Notarized Bid Securing Declaration using *NPC-MinGen Standard Form No. NPCMGNSF-INFR-03b*; and
- (f) Project Requirements, which shall include the following:
- a. Organizational chart for the contract to be bid *using NPC-MinGen Standard Form No. NPCMGNSF-INFR-04;*
  - b. List of contractor's key personnel (e.g., Project Manager, Project Engineers, Materials Engineers, and Foremen), to be assigned to the

- contract to be bid, with their complete qualification and experience data, using NPC-MinGen Standard Form No. NPCMGNSF-INFR-05, 6a, 6b & 07;
- c. List of contractor's major equipment units, which are owned, leased, and/or under purchase agreements, supported by proof of ownership or certification of availability of equipment from the equipment lessor/vendor for the duration of the project, as the case may be, using NPC-MinGen Standard Form No. NPCMGNSF-INFR-08 and its supporting documents; and
- (g) Original duly signed Omnibus Sworn Statement (OSS), using any of the following NPC-MinGen Standard Forms No.:  
*NPCMGNSF-INFR-09a – for Sole Proprietorship;*  
*or*  
*NPCMGNSF-INFR-09b – for Partnership/Cooperative/Corporation/ Joint Venture with the following supporting documents:*

**and** if applicable, Original Notarized Secretary's Certificate in case of a corporation, partnership, or cooperative; or Original Special Power of Attorney of all members of the joint venture giving full power and authority to its officer to sign the OSS and do acts to represent the Bidder.

Financial Documents

- (h) The prospective bidder's computation of Net Financial Contracting Capacity (NFCC) using NPC-MinGen Standard Form No. NPCMGNSF-INFR-10.

**Class "B" Documents**

- (i) If applicable, duly signed joint venture agreement (JVA) in accordance with RA No. 4566 and its IRR in case the joint venture is already in existence, using NPC-MinGen Standard Form No. *NPCMGNSF-INFR-11;*  
**or**  
duly notarized statements from all the potential joint venture partners stating that they will enter into and abide by the provisions of the JVA in the instance that the bid is successful.

**II. FINANCIAL COMPONENT ENVELOPE** *[Submit in three (3) copies- one (1) marked Original with the understanding that the Pass/Fail evaluation will be based only on the copy marked "Original"]*

- (j) Original of duly signed (each and every page) and accomplished Financial Bid Form, using NPC-MinGen Standard Form No. NPCMGNSF-INFR-12;  
**and**  
Other documentary requirements under RA No. 9184
- (k) Original of duly signed (each and every page) Bid Prices in the Bill of Quantities, using given form in Section VIII; and
- (l) Duly signed (each and every page) and accomplished Detailed Estimates



*Formusing NPC-MinGen Standard Form No. NPCMGNSF-INFR-13, including a summary sheet indicating the unit prices of construction materials, labor rates, and equipment rentals used in coming up with the Bidusing NPC form NPCMGNSF-INFR-14; and*

- (m) Cash Flow by Quarter or Month, as applicable (duly signed each and every page)

## STANDARD BIDDING FORMS

### NPC-MINDANAO GENERATION

- NPCMGNSF-INFR-01 - List of all Ongoing Government & Private Construction Contracts Including Contracts Awarded but not yet Started
- NPCMGNSF-INFR-02 - Statement of the Bidder's Single Largest Completed Contract (SLCC) similar to the contract to be bid
- NPCMGNSF-INFR-03a - Form of Bid Security : Surety Bond
- NPCMGNSF-INFR-03b - Bid Securing Declaration Form
- NPCMGNSF-INFR-04 - Contractor's Organizational Chart for the Project
- NPCMGNSF-INFR-05 - List of Key Personnel Proposed to be Assigned to the Project
- NPCMGNSF-INFR-6a - Key Personnel's Certificate of Employment (Professional Personnel)
- NPCMGNSF-INFR-6b - Key Personnel's Certificate of Employment (Construction Safety and Health Practitioner)
- NPCMGNSF-INFR-07 - Key Personnel's Bio-Data
- NPCMGNSF-INFR-08 - List of Equipment, Owned or Leased and/or under Purchase Agreement, Pledged to the Proposed Project
- NPCMGNSF-INFR-09a - Omnibus Sworn Statement (Sole Proprietorship)
- NPCMGNSF-INFR-09b - Omnibus Sworn Statement (Partnership/ Cooperative/Corporation//Joint Venture)
- NPCMGNSF-INFR-10 - Computation of Net Financial Contracting Capacity (NFCC)
- NPCMGNSF-INFR-11 - Joint Venture Agreement
- NPCMGNSF-INFR-12 - Bid Form
- NPCMGNSF-INFR-13 - Detailed Cost Estimate Form
- NPCMGNSF-INFR-14 - Summary Sheets of Materials Prices, Labor Rates and Equipment Rental Rates

BID DOCUMENTS

NAME OF PROJECT INSTALLATION OF CYLINDRICAL  
HYDROTOR TANK FOR USED OIL

SECTION IX- CHECKLIST OF TECHNICAL &  
FINANCIAL DOCUMENTS

PR NO /REF NO MG-A5M22-165INFRA2022-AG5-052

Standard Form Number : NPCMGNSF-INFR-01

**List of All Ongoing Government and Private Construction Contracts Including**

Business Name : \_\_\_\_\_

Business Address : \_\_\_\_\_

Name of Contract/Location/ Project Cost	a. Owner's Name b. Address c. Telephone Nos.	Nature of Work	Contractor's Role	
			Description	%
<u>Government</u>				
<u>Private</u>				

The bidder shall declare in this form all his on-going government and private contracts including contracts where the bidder (or agreement other than his current joint venture where he is a partner. Non declaration will be a ground for disqualification of bid

*Note: This statement shall be supported with Contract and/or Notice of Award (to be presented by the winning bid.*

Submitted by : \_\_\_\_\_  
(Printed Name & Signature)

Designation : \_\_\_\_\_

Date : \_\_\_\_\_

BID DOCUMENTS

NAME OF PROJECT : INSTALLATION OF CYLINDRICAL  
HYDROTOR TANK FOR USED OIL

SECTION IX- CHECKLIST OF TECHNICAL &  
FINANCIAL DOCUMENTS

PR NO./REF NO: MG-A5M22-165INFRA2022-AG5-052

Standard Form Number : NPCMGNSF-INFR-02

**The Statement of the Bidder's Single Largest Completed Contract (SLCC)**

Business Name : \_\_\_\_\_

Business Address : \_\_\_\_\_

Name of Contract	a. Owner's Name b. Address c. Telephone Nos.	Nature of Work	Contractor's Role	
			Description	%

Note: The bidder must state only one (1) Single Largest Completed Contract (SLCC) similar to the contract to be supported with:

1. Contract and Notice to Proceed
2. Certificate of Completion (for project completed within the year), or Owner's Certificate of Final Acceptance from the project owner other than the contractor, or a final rating of at least Satisfactory in the Constructor's Report from the private sector, an equivalent document (Ex. Official Receipt) shall be accepted.

Submitted by : \_\_\_\_\_  
(Printed Name & Signature)

Designation : \_\_\_\_\_

Date : \_\_\_\_\_

Standard Form No: NPCMGNSF-INFR-03a

**FORM OF BID SECURITY (SURETY BOND)**

BOND NO.: \_\_\_\_\_ DATE BOND EXECUTED: \_\_\_\_\_

By this bond, We (Name of Bidder) (hereinafter called "the Principal") and (Name of Surety) of (Name of Country of Surety), authorized to transact business in the Philippines (hereinafter called "the Employer") as Obligee, in the sum of amount in words & figures as prescribed in the bidding documents, callable on demand, for the payment of which sum, well and truly to be made, we, the said Principal and Surety bind ourselves, our successors and assigns, jointly and severally, firmly by these presents.

SEALED with our seals and dated this \_\_\_\_\_ day of \_\_\_\_\_ 20\_\_\_\_

WHEREAS, the Principal has submitted a written Bid to the Employer dated the \_\_\_\_\_ day of \_\_\_\_\_ 20\_\_\_\_, for the \_\_\_\_\_ (hereinafter called "the Bid").

NOW THEREFORE, the conditions of this obligation are:

- 1) If the Bidder withdraws his Bid during the period of bid validity specified in the Bidding Documents; or
- 2) If the Bidder does not accept the correction of arithmetical errors of his bid price in accordance with the Instructions to Bidder; or
- 3) If the Bidder, having determined as the LCB, fails or refuses to submit the required tax clearance, latest income and business tax returns and PhilGEPS registration certificate within the prescribed period; or
- 4) If the bidder having been notified of the acceptance of his bid and award of contract to him by the Entity during the period of bid validity:
  - a) Fails or refuses to execute the Contract; or
  - b) Fails or refuses to submit the required valid JVA, if applicable; or
  - c) Fails or refuses to furnish the Performance Security in accordance with the Instruction to Bidders;

Then this obligation shall remain in full force and effect, otherwise it shall be null and void.

PROVIDED HOWEVER, that the Surety shall not be:

- a) Liable for a grater sum than the specified penalty of this bond, nor
- b) Liable for a greater sum that the difference between the amount of the said Principal's Bid and the amount of the Bid that is accepted by the Employer.



BID DOCUMENTS

NAME OF PROJECT INSTALLATION OF CYLINDRICAL

HYDROTQR TANK FOR USED OIL

SECTION IX- CHECKLIST OF TECHNICAL &  
FINANCIAL DOCUMENTS

PR NO./REF NO MG-A5M22-166INFRA2022-AG5-D52

*Standard Form No: NPCMGNSF-INFR-03a*

*Page 2 of 2*

This Surety executing this instrument hereby agrees that its obligation shall be valid for 120 calendar days after the deadline for submission of Bids as such deadline is stated in the Instructions to Bidders or as it may be extended by the Employer, notice of which extension(s) to the Surety is hereby waived.

PRINCIPAL \_\_\_\_\_  
SIGNATURE(S) \_\_\_\_\_  
NAME(S) AND TITLE (S) \_\_\_\_\_  
SEAL \_\_\_\_\_

SURETY \_\_\_\_\_  
SIGNATURE(S) \_\_\_\_\_  
NAME(S) \_\_\_\_\_  
SEAL \_\_\_\_\_

Standard Form No: NPCMGNSF-INFR-03b

REPUBLIC OF THE PHILIPPINES)  
CITY OF \_\_\_\_\_) S.S.

**BID SECURING DECLARATION**  
**Project Identification No.: [Insert number]**

To: [Insert name and address of the Procuring Entity]

I/We, the undersigned, declare that:

1. I/We understand that, according to your conditions, bids must be supported by a Bid Security, which may be in the form of a Bid Securing Declaration.
2. I/We accept that: (a) I/we will be automatically disqualified from bidding for any procurement contract with any procuring entity for a period of two (2) years upon receipt of your Blacklisting Order; and, (b) I/we will pay the applicable fine provided under Section 6 of the Guidelines on the Use of Bid Securing Declaration, within fifteen (15) days from receipt of the written demand by the procuring entity for the commission of acts resulting to the enforcement of the bid securing declaration under Sections 23.1(b), 34.2, 40.1 and 69.1, except 69.1(f), of the IRR of RA No. 9184; without prejudice to other legal action the government may undertake.
3. I/We understand that this Bid Securing Declaration shall cease to be valid on the following circumstances:
  - a. Upon expiration of the bid validity period, or any extension thereof pursuant to your request;
  - b. I am/we are declared ineligible or post-disqualified upon receipt of your notice to such effect, and (i) I/we failed to timely file a request for reconsideration or (ii) I/we filed a waiver to avail of said right; and
  - c. I am/we are declared the bidder with the Lowest Calculated Responsive Bid, and I/we have furnished the performance security and signed the Contract.

IN WITNESS WHEREOF, I/We have hereunto set my/our hand/s this \_\_\_\_ day of [month] [year] at [place of execution].

[Insert NAME OF BIDDER OR ITS AUTHORIZED  
REPRESENTATIVE]

[Insert signatory's legal capacity]

Affiant

**[Jurat]**

[Format shall be based on the latest Rules on Notarial Practice]

Standard Form No: NPCMGNSF-INFR-04

### CONTRACTOR'S ORGANIZATIONAL CHART FOR THE CONTRACT

Submit Copy of the Organizational Chart that the Contractor intends to use to execute the Contract if awarded to him. Indicate in the chart the names of the Project Manager, Project Engineer, Foreman and other Key Engineering Personnel.

Attach the required Proposed Organizational Chart for the Contract as stated above

#### NOTES:

1. *This organization chart should represent the "Contractor's Organization" required for the Project, and not the organizational chart of the entire firm.*
2. *Each such nominated engineer/key personnel shall comply with and submit their complete qualification and experience data.*
3. *All these are required to be in the Technical Envelope of the Bidder.*

BID DOCUMENTS

NAME OF PROJECT : INSTALLATION OF CYLINDRICAL  
HYDROTQR TANK FOR USED OIL

SECTION IX- CHECKLIST OF TECHNICAL &  
FINANCIAL DOCUMENTS

PR NO v/REF NO MG-A5M22-165INFRA2022-AG5-052

Standard Form Number : NPCMGNSE-INFR-05

**LIST OF KEY PERSONNEL PROPOSED TO BE ASSIGNED TO THE CONTRACT  
(Based on the Minimum Key Personnel Required in the Bidding Documents)**

Business Name : \_\_\_\_\_  
Business : \_\_\_\_\_

	DESIGNATION				
1. Name					
2. Address					
3. Date of Birth					
4. Employed Since					
5. Experience					
6. Previous Employment					
7. Education					
8. PRC License					

*Required Attachments during Postqualification:*

1. Valid PRC License of the (professional) personnel
2. Certificate of Training with accreditation from DOLE of the Construction Safety and Health Officer
3. TESDA Training Certificate (NC II) of Welder or Electrician, whichever is applicable
4. Copy of Diploma and/or Service Record/Certificate of Employment of previous and/or current employer of Foreman, Welder, Plumber or Electrician, whichever is applicable shall be submitted during post qualification by the winning bidder.

Submitted by: \_\_\_\_\_  
(Printed name & Signature)

Designation: \_\_\_\_\_

Date: \_\_\_\_\_

One of the requirements from the bidder to be included in its Technical Envelope is a list of contractor's key personnel (based on the minimum key personnel required in the bidding documents) to be assigned to the contract to be bid, with their complete qualification and experience data (including the key personnel's signed written commitment to work for the project once awarded the contract).

Standard Form No: NPCMGNSF-INFR-06a

**KEY PERSONNEL'S CERTIFICATE OF EMPLOYMENT  
(PROFESSIONAL PERSONNEL)**

\_\_\_\_\_  
Issuance Date

**THE VICE PRESIDENT**  
National Power Corporation  
Mindanao Generation  
Maria Cristina, Iligan City

Dear Sir:

I am (Name of Nominee) a Licensed \_\_\_\_\_ Engineer with  
Professional License No. \_\_\_\_\_ Issued on \_\_\_\_\_ at \_\_\_\_\_  
(date of issuance) (place  
of issuance)

I hereby certify that (Name of Bidder) Has engaged my services as  
(Designation) for the (Name of Project), if awarded to it.

As (Designation), I supervised the following completed projects  
Similar to the contract under bidding:

NAME OF PROJECT	OWNER	COST	DATE COMPLETED
_____	_____	_____	_____
_____	_____	_____	_____

At present, I am supervising the following projects:

NAME OF PROJECT	OWNER	COST	DATE COMPLETED
_____	_____	_____	_____
_____	_____	_____	_____

In case of my separation for any reason whatsoever from the above-mentioned Contractor, I shall notify the National Power Corporation at least twenty one (21) days before the effective date of separation.

As (Designation), I know I will have to stay in the job site all the time to supervise and manage the Contract works to the best of my ability, and aware that I am authorized to handle only one (1) contract at a time.

*One of the requirements from the bidder to be included in its Technical Envelope is a list of contractor's key personnel (viz Project Manager, Project Engineer, Safety & Health Practitioner, Foremen, etc.), to be assigned to the contract to be bid, with their complete qualification and experience data (including the key personnel's signed written commitment to work for the project once awarded the contract).*



BID DOCUMENTS

NAME OF PROJECT: INSTALLATION OF CYLINDRICAL  
HYDROTOR TANK FOR USED OIL

SECTION IX- CHECKLIST OF TECHNICAL &  
FINANCIAL DOCUMENTS

PR. NO / REF. NO. MG-A5M22-165INFRA2022-AG5-052

Standard Form No: NPCMGNSF-INFR-06a  
Page 2 of 2

I do not allow the use of my name for the purpose of enabling the above-mentioned Contractor to qualify for the Contract without any firm commitment on my part to assume the post of (Designation) therefore, if the contract is awarded to him since I understand that to do so will be a sufficient ground for my disqualification as (Designation) in any future National Power Corporation bidding or employment with any Contractor doing business with the National Power Corporation.

\_\_\_\_\_  
(Name and Signature)  
AFFIANT

REPUBLIC OF THE PHILIPPINES )  
City/Municipality of \_\_\_\_\_ )S.S.

SUBSCRIBED AND SWORN TO before me this \_\_\_\_\_, day of \_\_\_\_ 20\_\_\_\_,  
affiant exhibiting to me his/her Community Tax Certificate No. \_\_\_\_\_ issued on  
\_\_\_\_\_ at \_\_\_\_\_, Philippines.

Notary Public  
Until 31 December 20 \_\_\_\_\_  
PTR No. \_\_\_\_\_  
Issued at: \_\_\_\_\_  
Issued on: \_\_\_\_\_  
TIN No. \_\_\_\_\_

Doc. No. \_\_\_\_\_  
Page No. \_\_\_\_\_  
Book No. \_\_\_\_\_  
Series of \_\_\_\_\_

*One of the requirements from the bidder to be included in its Technical Envelope is a list of contractor's key personnel (viz. Project Manager, Project Engineer, Safety & Health Practitioner, Foremen, etc.), to be assigned to the contract to be bid, with their complete qualification and experience data (including the key personnel's signed written commitment to work for the project once awarded the contract)*

Standard Form No: NPCMGNSF-INFR-06b



BID DOCUMENTS

NAME OF PROJECT: INSTALLATION OF CYLINDRICAL  
HYDROTOR TANK FOR USED OIL

SECTION IX- CHECKLIST OF TECHNICAL &  
FINANCIAL DOCUMENTS

PR NO./REF. NO: MG-A5M22-165INFRA2022-AG5-052

Standard Form No: NPCMGNSF-INFR-06b  
Page 2 of 2

I do not allow the use of my name for the purpose of enabling the above-mentioned Contractor to qualify for the Contract without any firm commitment on my part to assume the post of Safety and Health Practitioner, if the contract is awarded to him since I understand that to do so will be a sufficient ground for my disqualification as Safety and Health Practitioner in any future National Power Corporation bidding or employment with any Contractor doing business with the National Power Corporation.

\_\_\_\_\_  
(Name and Signature)  
AFFIANT

REPUBLIC OF THE PHILIPPINES )  
City/Municipality of \_\_\_\_\_ )S.S.

SUBSCRIBED AND SWORN TO before me this \_\_\_\_\_, day of \_\_\_\_\_ 20\_\_\_\_,  
affiant exhibiting to me his/her Community Tax Certificate No. \_\_\_\_\_ issued on  
\_\_\_\_\_ at \_\_\_\_\_, Philippines.

Notary Public  
Until 31 December 20\_\_\_\_  
PTR No. \_\_\_\_\_  
Issued at: \_\_\_\_\_  
Issued on: \_\_\_\_\_  
TIN No. \_\_\_\_\_

Doc. No. \_\_\_\_\_  
Page No. \_\_\_\_\_  
Book No. \_\_\_\_\_  
Series of \_\_\_\_\_

*One of the requirements from the bidder to be included in its Technical Envelope is a list of contractor's key personnel (viz. Project Manager, Project Engineer, Safety & Health Practitioner, Foremen, etc.) to be assigned to the contract to be bid, with their complete qualification and experience data (including the key personnel's signed written commitment to work for the project once awarded the contract).*

Standard Form No: NPCMGNSF-INFR-07

**KEY PERSONNEL  
(FORMAT OF BIO-DATA)**

Give the detailed information of the following personnel who are scheduled to be assigned as full-time staff for the project. Fill up a form for each person.

- 1. Name : \_\_\_\_\_
- 2. Date of Birth : \_\_\_\_\_
- 3. Nationality : \_\_\_\_\_
- 4. Education and Degrees : \_\_\_\_\_
- 5. Specialty : \_\_\_\_\_
- 6. Registration : \_\_\_\_\_
- 7. Length of Service with the Firm : \_\_\_\_\_ Year from \_\_\_\_\_ (months) \_\_\_\_\_ (year) To \_\_\_\_\_ (months) \_\_\_\_\_ (year)
- 8. Years of Experience : \_\_\_\_\_

9. If item 7 is less than the required number of years stated in BDS Section III- ITB Clause 10.4, give name and length of service with previous employers to satisfy the required number of years of experience within the last ten (10) years (attached additional sheet/s), if necessary:

<u>Name and Address of Employer</u>	<u>Length of Service</u>
_____	Year(s) from _____ to _____
_____	Year(s) from _____ to _____
_____	Year(s) from _____ to _____

**10. Experience:**

This should cover the past ten (10) years of experience. (Attached as many pages as necessary to show involvement of personnel in projects using the format below).

*One of the requirements from the bidder to be included in its Technical Envelope is a list of contractor's key personnel (viz Project Manager, Project Engineer, Safety & Health Practitioner, Foremen, etc.), to be assigned to the contract to be bid, with their complete qualification and experience data (including the key personnel's signed written commitment to work for the project once awarded the contract).*

Standard Form No: NPCMGNSF-INFR-07  
Page 2 of 2

- 1. Name : \_\_\_\_\_
- 2. Name and Address of Owner : \_\_\_\_\_
- 3. Name and Address of the Owner's Engineer (Consultant) : \_\_\_\_\_
- 4. Indicate the Features of Project (particulars of the project components and any other particular interest connected with the project) : \_\_\_\_\_
- 5. Contract Amount Expressed in Philippine Currency : \_\_\_\_\_
- 6. Position : \_\_\_\_\_
- 7. Structures for which the employee was responsible : \_\_\_\_\_
- 8. Assignment Period : from \_\_\_\_\_ (months) \_\_\_\_\_ (years)  
to \_\_\_\_\_ (months) \_\_\_\_\_ (years)

\_\_\_\_\_  
Name and Signature of  
Employee

It is hereby certified that the above personnel can be assigned to this project, if the contract is awarded to our company.

\_\_\_\_\_  
(Place and Date)

\_\_\_\_\_  
(The Authorized Representative)

*One of the requirements from the bidder to be included in its Technical Envelope is a list of contractor's key personnel (viz. Project Manager, Project Engineer, Safety & Health Practitioner, Foremen, etc.), to be assigned to the contract to be bid, with their complete qualification and experience data (including the key personnel's signed written commitment to work for the project once awarded the contract).*

BID DOCUMENTS

NAME OF PROJECT . INSTALLATION OF CYLINDRICAL  
HYDROTOR TANK FOR USED OIL

SECTION IX- CHECKLIST OF TECHNICAL &  
FINANCIAL DOCUMENTS

PR.NO./REF. NO MG-A5M22-105INFRA2022-AG5-052

Standard Form Number : NPCMGNSF-INFR - 08

**LIST OF EQUIPMENT, OWNED OR LEASED AND/OR UNDER PI**  
**(Based on the Minimum Equipment Required in the Bio**

Business Name : \_\_\_\_\_  
Business : \_\_\_\_\_

Description	Model/Year	Capacity/ Performance / Size	Plate No.	Motor No. / Body No.
<b>A. Owned</b>				
i.				
ii.				
iii.				
iv.				
<b>B. Leased</b>				
i.				
ii.				
iii.				
iv.				
<b>C. Under Purchased Agreements</b>				
i.				
ii.				
iii.				
iv.				

Submitted by: \_\_\_\_\_  
(Printed name & Signature)

Designation: \_\_\_\_\_

Date: \_\_\_\_\_

*One of the requirements from the bidder to be included in its Technical Envelope is the list of its equipment units pledged for the contract which are owned (supported by proof/s of ownership), leased, and/or under purchase agreements (with corresponding engine numbers, availability of equipment from the equipment lessor/vendor for the duration of the project.*



Standard Form No: NPCMGNSF-INFR-09a

**Omnibus Sworn Statement (Revised)**  
(SOLE PROPRIETORSHIP)

---

REPUBLIC OF THE PHILIPPINES )  
CITY/MUNICIPALITY OF \_\_\_\_\_ ) S.S.

**AFFIDAVIT**

I, [Name of Affiant], of legal age, [Civil Status], [Nationality], and residing at [Address of Affiant], after having been duly sworn in accordance with law, do hereby depose and state that:

1. I am the sole proprietor or authorized representative of [Name of Bidder] with office address at [address of Bidder];
2. As the owner and sole proprietor, or authorized representative of [Name of Bidder], I have full power and authority to do, execute and perform any and all acts necessary to participate, submit the bid, and to sign and execute the ensuing contract for [Name of the Project] of the National Power Corporation-Mindanao Generation, as shown in the attached duly notarized Special Power of Attorney;
3. [Name of Bidder] is not "blacklisted" or barred from bidding by the Government of the Philippines or any of its agencies, offices, corporations, or Local Government Units, foreign government/foreign or international financing institution whose blacklisting rules have been recognized by the Government Procurement Policy Board, **by itself or by relation, membership, association, affiliation, or controlling interest with another blacklisted person or entity as defined and provided for in the Uniform Guidelines on Blacklisting;**
4. Each of the documents submitted in satisfaction of the bidding requirements is an authentic copy of the original, complete, and all statements and information provided therein are true and correct;
5. [Name of Bidder] is authorizing the Head of the Procuring Entity or its duly authorized representative(s) to verify all the documents submitted;
6. The owner or sole proprietor is not related to the Head of the Procuring Entity, members of the Bids and Awards Committee (BAC), the Technical Working Group, and the BAC Secretariat, the head of the Project Management Office or the end-user unit, and the project consultants by consanguinity or affinity up to the third civil degree;
7. [Name of Bidder] complies with existing labor laws and standards; and
8. [Name of Bidder] is aware of and has undertaken the responsibilities as a Bidder in compliance with the Philippine Bidding Documents, which includes:
  - a. Carefully examining all of the Bidding Documents;
  - b. Acknowledging all conditions, local or otherwise, affecting the implementation of the Contract;

Standard Form No: NPCMGNSF-INFR-09a

Page 2 of 2

- c. Making an estimate of the facilities available and needed for the contract to be bid, if any; and
  - d. Inquiring or securing Supplemental/Bid Bulletin(s) issued for the *[Name of the Project]*.
9. *[Name of Bidder]* did not give or pay directly or indirectly, any commission, amount, fee, or any form of consideration, pecuniary or otherwise, to any person or official, personnel or representative of the government in relation to any procurement project or activity.
10. **In case advance payment was made or given, failure to perform or deliver any of the obligations and undertakings in the contract shall be sufficient grounds to constitute criminal liability for Swindling (Estafa) or the commission of fraud with unfaithfulness or abuse of confidence through misappropriating or converting any payment received by a person or entity under an obligation involving the duty to deliver certain goods or services, to the prejudice of the public and the government of the Philippines pursuant to Article 315 of Act No. 3815 s. 1930, as amended, or the Revised Penal Code.**

IN WITNESS WHEREOF, I have hereunto set my hand this \_\_ day of \_\_, 20\_\_ at \_\_\_\_\_, Philippines.

*[Insert NAME OF BIDDER OR ITS AUTHORIZED REPRESENTATIVE]*  
*[Insert signatory's legal capacity]*  
Affiant

**[Jurat]**

*[Format shall be based on the latest Rules on Notarial Practice]*

Standard Form No: NPCMGNSF-INFR-09b

**Omnibus Sworn Statement (Revised)**  
PARTNERSHIP/COOP/CORP/JOINT VENTURE

REPUBLIC OF THE PHILIPPINES )  
CITY/MUNICIPALITY OF \_\_\_\_\_ ) S.S.

**AFFIDAVIT**

I, [Name of Affiant], of legal age, [Civil Status], [Nationality], and residing at [Address of Affiant], after having been duly sworn in accordance with law, do hereby depose and state that:

1. I am the duly authorized and designated representative of [Name of Bidder] with office address at [address of Bidder];
2. I am granted full power and authority to do, execute and perform any and all acts necessary to participate, submit the bid, and to sign and execute the ensuing contract for [Name of the Project] of the National Power Corporation-Mindanao Generation, as shown in the attached [state title of attached document showing proof of authorization (e.g., duly notarized Secretary's Certificate, Board/Partnership Resolution, or Special Power of Attorney, whichever is applicable);];
3. [Name of Bidder] is not "blacklisted" or barred from bidding by the Government of the Philippines or any of its agencies, offices, corporations, or Local Government Units, foreign government/foreign or international financing institution whose blacklisting rules have been recognized by the Government Procurement Policy Board, **by itself or by relation, membership, association, affiliation, or controlling interest with another blacklisted person or entity as defined and provided for in the Uniform Guidelines on Blacklisting;**
4. Each of the documents submitted in satisfaction of the bidding requirements is an authentic copy of the original, complete, and all statements and information provided therein are true and correct;
5. [Name of Bidder] is authorizing the Head of the Procuring Entity or its duly authorized representative(s) to verify all the documents submitted;
6. *[If a partnership or cooperative:]* None of the officers and members of [Name of Bidder] is related to the Head of the Procuring Entity, members of the Bids and Awards Committee (BAC), the Technical Working Group, and the BAC Secretariat, the head of the Project Management Office or the end-user unit, and the project consultants by consanguinity or affinity up to the third civil degree;

*[If a corporation or joint venture:]* None of the officers, directors, and controlling stockholders of [Name of Bidder] is related to the Head of the Procuring Entity, members of the Bids and Awards Committee (BAC), the Technical Working Group, and the BAC Secretariat, the head of the Project Management Office or the end-user unit, and the project consultants by consanguinity or affinity up to the third civil degree;

Standard Form No: NPCMGNSF-INFR-09b

Page 2 of 2

- 7. *[Name of Bidder]* complies with existing labor laws and standards; and
- 8. *[Name of Bidder]* is aware of and has undertaken the responsibilities as a Bidder in compliance with the Philippine Bidding Documents, which includes:
  - a. Carefully examining all of the Bidding Documents;
  - b. Acknowledging all conditions, local or otherwise, affecting the implementation of the Contract;
  - c. Making an estimate of the facilities available and needed for the contract to be bid, if any; and
  - d. Inquiring or securing Supplemental/Bid Bulletin(s) issued for the *[Name of the Project]*.
- 9. *[Name of Bidder]* did not give or pay directly or indirectly, any commission, amount, fee, or any form of consideration, pecuniary or otherwise, to any person or official, personnel or representative of the government in relation to any procurement project or activity.
- 10. **In case advance payment was made or given, failure to perform or deliver any of the obligations and undertakings in the contract shall be sufficient grounds to constitute criminal liability for Swindling (Estafa) or the commission of fraud with unfaithfulness or abuse of confidence through misappropriating or converting any payment received by a person or entity under an obligation involving the duty to deliver certain goods or services, to the prejudice of the public and the government of the Philippines pursuant to Article 315 of Act No. 3815 s. 1930, as amended, or the Revised Penal Code.**

IN WITNESS WHEREOF, I have hereunto set my hand this \_\_ day of \_\_, 20\_\_ at \_\_\_\_\_, Philippines.

*[Insert NAME OF BIDDER OR ITS AUTHORIZED REPRESENTATIVE]*  
*[Insert signatory's legal capacity]*  
Affiant

**[Jurat]**  
*[Format shall be based on the latest Rules on Notarial Practice]*

Standard Form No: NPCMGNSF-INFR-10

**NET FINANCIAL CONTRACTING CAPACITY (NFCC)**

A. Summary of the Bidder's/Contractor's assets and liabilities on the basis of the income tax return and audited financial statement for the immediately preceding calendar year are:

	Year 20__
1. Total Assets	
2. Current Assets	
3. Total Liabilities	
4. Current Liabilities	
5. Net Worth (1-3)	
6. Net Working Capital (2-4)	

B. The Net Financial Contracting Capacity (NFCC) based on the above data is computed as follows:

NFCC = [(Current assets minus current liabilities) x 15] minus the value of all outstanding or uncompleted portions of the projects under ongoing contracts, including awarded contracts yet to be started coinciding with the contract for this Project.

NFCC – P \_\_\_\_\_

Herewith attached is certified true copy of the audited financial statement, stamped "RECEIVED" by the BIR or BIR authorized collecting agent for the immediately preceding calendar year.

Submitted by:

\_\_\_\_\_  
Name of Bidder/Contractor

\_\_\_\_\_  
Signature of Authorized Representative

Date: \_\_\_\_\_

Standard Form No: NPCMGNSF-INFR-11

**JOINT VENTURE AGREEMENT**

**KNOW ALL MEN BY THESE PRESENTS:**

That this JOINT VENTURE AGREEMENT is entered in to by and between:  
\_\_\_\_\_ of legal age, (civil status), authorized representative of  
\_\_\_\_\_ and a resident of \_\_\_\_\_.

- and -

\_\_\_\_\_ of legal age, (civil status), authorized representative of  
\_\_\_\_\_ and a resident of \_\_\_\_\_.

That both parties agree to join together their capital, manpower, equipment, and other resources and efforts to enable the Joint Venture to participate in the Bidding and Undertaking of the hereunder stated Contract of the **National Power Corporation**.

**NAME OF FIRM**

**CAPITAL CONTRIBUTION**

\_\_\_\_\_

That the capital contribution of each member firm:

**NAME OF FIRM**

**CAPITAL CONTRIBUTION**

1  
2

DHD  
DHD

That both parties agree to be jointly and severally liable for their participation in the Bidding and Undertaking of the said contract.

That both parties agree that \_\_\_\_\_ and/or \_\_\_\_\_ shall be the Official Representative/s of the Joint Venture, and are granted full power and authority to do, execute and perform any and all acts necessary and/or to represent the Joint Venture in the Bidding and Undertaking of the said contract, as fully and effectively and the Joint Venture may do and if personally present with full power of substitution and revocation.

That this Joint Venture Agreement shall remain in effect only for the above stated Contract until terminated by both parties.

\_\_\_\_\_  
Name & Signature of Authorized  
Representative  
\_\_\_\_\_  
Official Designation  
\_\_\_\_\_  
Name of Firm

\_\_\_\_\_  
Name & Signature of  
Authorized Representative  
\_\_\_\_\_  
Official Designation  
\_\_\_\_\_  
Name of Firm

**Witnesses**

\_\_\_\_\_

*If the bidder is a joint venture, one of the requirements is the submission of a valid joint venture agreement.*



Standard Form No: NPCMGNSF-INFR-11

Page 2 of 2

**ACKNOWLEDGEMENT**

BEFORE ME, a Notary Public for and in \_\_\_\_\_, Philippines, this \_\_\_\_\_ day of \_\_\_\_\_, 20\_\_\_\_, personally appeared \_\_\_\_\_, authorized representative, of \_\_\_\_\_ with Community Tax Certificate No. \_\_\_\_\_, issued at \_\_\_\_\_, on \_\_\_\_\_, AND \_\_\_\_\_ authorized representative, of \_\_\_\_\_ with Community Tax Certificate No. \_\_\_\_\_, issued at \_\_\_\_\_, on \_\_\_\_\_ known to me to be the same person who executed the foregoing instrument consisting of two (2) pages, including the page whereon the acknowledgements are written, all pages signed by both parties and their instrumental witnesses and they acknowledged before me that the same are their free and voluntary acts and deeds and that of the Corporations they represents.

WITNESS MY HAND AND NOTARIAL SEAL, at the place and on the date first above written.

Notary Public  
Until 31 December 20 \_\_\_\_\_  
PTR No. \_\_\_\_\_  
Issued at. \_\_\_\_\_  
Issued on: \_\_\_\_\_  
TIN No. \_\_\_\_\_

Doc. No. \_\_\_\_\_  
Page No. \_\_\_\_\_  
Book No. \_\_\_\_\_  
Series of \_\_\_\_\_

*If the bidder is a joint venture, one of the requirements is the submission of a valid joint venture agreement*  
Standard Form No: NPCMGNSF-INFR-12

## Bid Form for the Procurement of Infrastructure Projects

### BID FORM

Date : \_\_\_\_\_

Project Identification No. : \_\_\_\_\_

To: **The Vice President**  
National Power Corporation  
Mindanao Generation  
Maria Cristina, Iligan City

Having examined the Philippine Bidding Documents (PBDs) including the Supplemental or Bid Bulletin Numbers [insert numbers], the receipt of which is hereby duly acknowledged, we, the undersigned, declare that:

- a. We have no reservation to the PBDs, including the Supplemental or Bid Bulletins, for the Procurement Project: [insert name of contract];
- b. We offer to execute the Works for this Contract in accordance with the PBDs;
- c. The total price of our Bid in words and figures, excluding any discounts offered below is: [insert information];
- d. The discounts offered and the methodology for their application are: [insert information];
- e. The total bid price includes the cost of all taxes, such as, but not limited to: [specify the applicable taxes, e.g. (i) value added tax (VAT), (ii) income tax, (iii) local taxes, and (iv) other fiscal levies and duties], which are itemized herein and reflected in the detailed estimates,
- f. Our Bid shall be valid within the a period stated in the PBDs, and it shall remain binding upon us at any time before the expiration of that period;
- g. If our Bid is accepted, we commit to obtain a Performance Security in the amount of [insert percentage amount] percent of the Contract Price for the due performance of the Contract, or a Performance Securing Declaration in lieu of the the allowable forms of Performance Security, subject to the terms and conditions of issued GPPB guidelines<sup>1</sup> for this purpose;
- h. We are not participating, as Bidders, in more than one Bid in this bidding process, other than alternative offers in accordance with the Bidding Documents;
- i. We understand that this Bid, together with your written acceptance thereof included in your notification of award, shall constitute a binding contract between us, until a formal Contract is prepared and executed; and

Standard Form No: NPCMGNSF-INFR-12

Page 2 of 2

<sup>1</sup> currently based on GPPB Resolution No. 09-2020

- j. We understand that you are not bound to accept the Lowest Calculated Bid or any other Bid that you may receive.
- k. We likewise certify/confirm that the undersigned, is the duly authorized representative of the bidder, and granted full power and authority to do, execute and perform any and all acts necessary to participate, submit the bid, and to sign and execute the ensuing contract for the [Name of Project] of the National Power Corporation-Mindanao Generation.
- l. We acknowledge that failure to sign each and every page of this Bid Form, including the Bill of Quantities, shall be a ground for the rejection of our bid.

Name: \_\_\_\_\_

Legal Capacity: \_\_\_\_\_

Signature: \_\_\_\_\_

Duly authorized to sign the Bid for and behalf of: \_\_\_\_\_

Date: \_\_\_\_\_



Standard Form No: NPCMGNSF-INFR-14

**SUMMARY SHEETS OF MATERIALS PRICES, LABOR RATES AND  
EQUIPMENT RENTAL RATES**

Name of Bidder: \_\_\_\_\_

**I. Unit Prices of Materials**

Materials Description	Unit	Unit Price
-----------------------	------	------------

**II. Manpower Hourly Rates**

Designation	Rate/Hr.
-------------	----------

Worki

**III. Equipment Hourly Rental Rates**

Equipment Description	Rental Rate/Hr.
-----------------------	-----------------

\_\_\_\_\_  
Name, Signature of Authorized Representative

\_\_\_\_\_  
Designation

## Performance Securing Declaration (Revised)

*[If used as an alternative performance security but it is not required to be submitted with the Bid, as it shall be submitted within ten (10) days after receiving the Notice of Award]*

REPUBLIC OF THE PHILIPPINES)  
 CITY OF \_\_\_\_\_ ) S.S.

### PERFORMANCE SECURING DECLARATION

Invitation to Bid: [Insert Reference Number indicated in the Bidding Documents]

To: [Insert name and address of the Procuring Entity]

I/We, the undersigned, declare that:

1. I/We understand that, according to your conditions, to guarantee the faithful performance by the supplier/distributor/manufacturer/contractor/consultant of its obligations under the Contract, I/we shall submit a Performance Securing Declaration within a maximum period of ten (10) calendar days from the receipt of the Notice of Award prior to the signing of the Contract.
2. I/We accept that: I/we will be automatically disqualified from bidding for any procurement contract with any procuring entity for a period of one (1) year for the first offense, or two (2) years **for the second offense**, upon receipt of your Blacklisting Order if I/We have violated my/our obligations under the Contract.
3. I/We understand that this Performance Securing Declaration shall cease to be valid upon:
  - a. issuance by the Procuring Entity of the Certificate of Final Acceptance, subject to the following conditions:
    - i. Procuring Entity has no claims filed against the contract awardee;
    - ii. It has no claims for labor and materials filed against the contractor; and
    - iii. Other terms of the contract; or
  - b. replacement by the winning bidder of the submitted PSD with a performance security in any of the prescribed forms under Section 39.2 of the 2016 revised IRR of RA No. 9184 as required by the end-user.

**IN WITNESS WHEREOF**, I/We have hereunto set my/our hand/s this \_\_\_\_ day of [month] [year] at [place of execution].

*[Insert NAME OF BIDDER OR ITS  
 AUTHORIZED REPRESENTATIVE]  
 [Insert signatory's legal capacity]  
 Affiant*

**[Jurat]**

*[Format shall be based on the latest Rules on Notarial Practice]*



## Contract Agreement Form for the Procurement of Infrastructure Projects (Revised)

*[not required to be submitted with the Bid, but it shall be submitted within ten (10) days after receiving the Notice of Award]*

### CONTRACT AGREEMENT

THIS AGREEMENT, made this *[insert date]* day of *[insert month]*, *[insert year]* between *[name and address of PROCURING ENTITY]* (hereinafter called the "Entity") and *[name and address of Contractor]* (hereinafter called the "Contractor").

WHEREAS, the Entity is desirous that the Contractor execute *[name and identification number of contract]* (hereinafter called "the Works") and the Entity has accepted the Bid for *[contract price in words and figures in specified currency]* by the Contractor for the execution and completion of such Works and the remedying of any defects therein.

NOW THIS AGREEMENT WITNESSETH AS FOLLOWS:

1. In this Agreement, words and expressions shall have the same meanings as are respectively assigned to them in the Conditions of Contract hereinafter referred to.
2. The following documents as required by the 2016 revised Implementing Rules and Regulations of Republic Act No. 9184 shall be deemed to form and be read and construed as part of this Agreement, *viz.*:
  - a. Philippine Bidding Documents (PBDs);
    - i. Drawings/Plans;
    - ii. Specifications;
    - iii. Bill of Quantities;
    - iv. General and Special Conditions of Contract;
    - v. Supplemental or Bid Bulletins, if any;
  - b. Winning bidder's bid, including the Eligibility requirements, Technical and Financial Proposals, and all other documents or statements submitted;

Bid form, including all the documents/statements contained in the Bidder's bidding envelopes, as annexes, and all other documents submitted (*e.g.*, Bidder's response to request for clarifications on the bid), including corrections to the bid, if any, resulting from the Procuring Entity's bid evaluation;

- c. Performance Security;
- d. Notice of Award of Contract and the Bidder's conforme thereto; and
- e. Other contract documents that may be required by existing laws and/or the Procuring Entity concerned in the PBDs. **Winning bidder agrees that additional contract documents or information prescribed by the GPPB that are subsequently required for submission after the contract execution, such as the Notice to Proceed, Variation Orders, and Warranty Security, shall likewise form part of the Contract.**

3. In consideration for the sum of *[total contract price in words and figures]* or such other sums as may be ascertained, *[Named of the bidder]* agrees to *[state the object of the contract]* in accordance with his/her/its Bid.
4. The *[Name of the procuring entity]* agrees to pay the above-mentioned sum in accordance with the terms of the Bidding.

IN WITNESS whereof the parties thereto have caused this Agreement to be executed the day and year first before written.

*[Insert Name and Signature]*

*[Insert Name and Signature]*

*[Insert Signatory's Legal Capacity]*

*[Insert Signatory's Legal Capacity]*

for:

for:

*[Insert Procuring Entity]*

*[Insert Name of Supplier]*

**Acknowledgment**

*[Format shall be based on the latest Rules on Notarial Practice]*

Worki

g Draft

