



REPUBLIC OF THE PHILIPPINES  
**NATIONAL POWER CORPORATION**  
(Pambansang Korporasyon sa Elektrisidad)

## BID DOCUMENTS

**Name of Project :** SUPPLY, DELIVERY, INSTALLATION AND TEST OF 1X35 KL FOST AND 2X60 KL FOST FOR PATNANUNGAN DPP, PALANAN DPP AND JOMALIG DPP INCLUDING CONSTRUCTION OF ASSOCIATED FACILITIES UNDER PACKAGE 1

**Project Location :** PALANAN, ISABELA  
PATNANUNGAN ISLAND, QUEZON PROVINCE  
JOMALIG ISLAND, QUEZON PROVINCE

**Specs No. :** LuzP20Z1179Se | HO-PIB22 - 023 (PBA)

**Contents :** /

PART I	-	INSTRUCTIONS TO BIDDERS
PART II	-	BID DATA SHEET
PART III	-	GENERAL CONDITIONS OF CONTRACT
PART IV	-	SPECIAL CONDITIONS OF CONTRACT
PART V	-	TECHNICAL SPECIFICATIONS
PART VI	-	TECHNICAL DATA SHEETS (NOT USED)
PART VII	-	BILL OF QUANTITIES
PART VIII	-	BIDDING FORMS
PART IX	-	BID & REFERENCE DRAWINGS

Design and Development Department



# SECTION I

# INVITATION TO BID

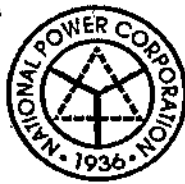

# National Power Corporation

## INVITATION TO BID

### PUBLIC BIDDING – BCS 2022-0394

1. The NATIONAL POWER CORPORATION (NPC), through its approved Corporate Budget of CY 2022 intends to apply the sum of **(Please see schedule below)** being the Approved Budget for the Contract (ABC) to payments under the contract. Bids received in excess of the ABC shall be automatically rejected at Bid opening.

PR Nos./PB Ref No. & Description	Similar Contracts	Pre-bid Conference	Bid Submission / Opening	ABC/ Amt. of Bid Docs
HO-TFM22-091 / PB220705-HG00236  Supply, Delivery, Installation, Test and Commissioning of 1 x 600kW Standby Power (Open Type) Diesel Generator Set and Associated Electrical Equipment for NPC Head Office	Supply, Delivery, Installation, Test and Commissioning of Diesel Generating set/s with at least one unit capacity of 300 kW Prime, Continuous or Standby Power	24 June 2022 9:30 A.M	06 July 2022 9:30 A.M	₱ 12,108,600.00 / ₱ 25,000.00
HO-PIB22-003 / PB220330-HG00051 (PB4)  Supply, Delivery, Installation and Test of 1 x 35 KL FOST and 2 x 60 KL FOST for Patnanungan DPP, Palanan DPP and Jomalig DPP Including Construction of Associated Facilities under Package 1  • PCAB License: License Category of at least "Category D – General Building" and registration classification of at least "Small B – Building and Industrial Plant" or "Small B – Mechanical Work"	Construction of Fuel Oil Storage Tank, including its concrete foundation and associated works with capacity of not less 35 cu.m	24 June 2022 9:30 A.M	06 July 2022 9:30 A.M	₱ 14,497,000.00 / ₱ 25,000.00
S1-MS622-005, S1-NPS22-007 S1-CTL22-003 / PB220705-AD00237  Supply, Delivery, Test and Training of Unmanned Aerial Vehicle (UAV) for Masbate, Catanduanes and Northern Palawan Substations and 69kV Transmission Lines	Supply, delivery and test of Unmanned Aerial Vehicle (Drone with Accessories)	24 June 2022 9:30 A.M	06 July 2022 9:30 A.M	₱ 2,650,000.00 / ₱ 5,000.00

<p>SO-OPD21-009 / PB211202-JC00437 (PB3)</p> <p>Supply, Delivery, Installation, Test and Commissioning of Four (4) Units of Diesel Gensets for Sibolo DPP and Guiwanon DPP in Western Visayas Including Its Associated Electrical Equipment under Package 31</p>	<p>Supply, Delivery, Installation, Test and Commissioning or Construction of Power Facilities, Installation, Test and Commissioning of Diesel Generating Set/s with at least one-unit capacity of 50 kW Prime or Continuous Power with power transformer/s of at least 75 kVA rating</p>	<p>24 June 2022 9:30 A.M</p>	<p>06 July 2022 9:30 A.M</p>	<p>P 18,807,960.00 / P 25,000.00</p>
<p align="center"><b>Venue: Kañao Function Room, NPC Bldg. Diliman, Quezon City</b></p>				

2. The NPC now invites bids for Items listed above. Delivery of the Goods is required (see table below) specified in the Technical Specifications. Bidders should have completed, within (see table below) from the date of submission and receipt of bids, a contract similar to the Project. The description of an eligible bidder is contained in the Bidding Documents, particularly, in Section II. (Instruction to Bidders).

PR No/s. / PB Ref No/s.	Delivery Period / Contract Duration	Relevant Period of SLCC reckoned from the date of submission & receipt of bids
HO-TFM22-091	One Hundred Eighty (180) Calendar Days	Fifteen (15) Years
HO-PIB22-003	Two Hundred Forty (240) Calendar Days	-
S1-MS622-005 & 2 OTHERS	Sixty (60) Calendar Days	Five (5) Years
SO-OPD21-009	Two Hundred Forty (240) Calendar Days	Fifteen (15) Years

3. Bidding will be conducted through open competitive bidding procedures using a non-discretionary "pass/fail" criterion as specified in the 2016 revised Implementing Rules and Regulations (IRR) of Republic Act (RA) No. 9184.

Bidding is restricted to Filipino citizens/sole proprietorships, partnerships, or organizations with at least sixty percent (60%) interest or outstanding capital stock belonging to citizens of the Philippines, and to citizens or organizations of a country the laws or regulations of which grant similar rights or privileges to Filipino citizens, pursuant to RA 5183.

4. Prospective Bidders may obtain further information from National Power Corporation, Bids and Contracts Services Division and inspect the Bidding Documents at the address given below during office hours (8:00AM to 5:00PM), Monday to Friday.
5. A complete set of Bidding Documents may be acquired by interested Bidders from the given address and website(s) and upon payment of the applicable fee for the Bidding Documents, pursuant to the latest Guidelines issued by the GPPB. Bidding fee may be refunded in accordance with the guidelines based on the grounds provided under Section 41 of R.A. 9184 and its Revised IRR.

6. The National Power Corporation will hold Pre-Bid Conference (**see table above**) and/or through video conferencing or webcasting which shall be open to prospective bidders.

Only registered bidder/s shall be allowed to participate for the conduct of virtual pre-bid conference. **Unregistered bidders** may attend the Pre-Bid Conference at the Kañao Room, NPC subject to the following:

- a. Only a maximum of two (2) representatives from each bidder / company shall be allowed to participate during the virtual pre-bid conference.
  - b. A "No Face mask / No Entry" policy shall be implemented in the NPC premises. Face mask shall be 3-ply surgical or KN95 mask type.
  - c. The requirements herein stated including the medium of submission shall be subject to GPPB Resolution No. 09-2020 dated 07 May 2020
  - d. The Guidelines on the Implementation of Early Procurement Activities (EPA) shall be subject to GPPB Circular No. 06-2019 dated 17 July 2019
7. Bids must be duly received by the BAC Secretariat through (i) manual submission at the office address indicated below; (ii) online or electronic submission before the specified time stated in the table above for opening of bids. Late bids shall not be accepted.
8. All Bids must be accompanied by a bid security in any of the acceptable forms and in the amount stated in ITB Clause 14.
9. Bid opening shall be on Kañao Function Room, NPC Head Office, Diliman, Quezon City and/or via online platform to be announced by NPC. Bids will be opened in the presence of the bidders' representatives who choose to attend the activity.
10. The National Power Corporation reserves the right to reject any and all bids, declare a failure of bidding, or not award the contract at any time prior to contract award in accordance with Sections 35.6 and 41 of the 2016 revised IRR of R.A. No. 9184, without thereby incurring any liability to the affected bidder or bidders.
11. For further information, please refer to:

**Bids and Contracts Services Division,  
Logistics Department**

BIR Road cor. Quezon Avenue

Diliman, Quezon City

Tel Nos.: 8924-5211 and 8921-3541 local 5361/5239/5504

Fax No.: 8922-1622

Email: [bcsd@napocor.gov.ph](mailto:bcsd@napocor.gov.ph) / [bcsd\\_napocor@yahoo.com](mailto:bcsd_napocor@yahoo.com)

12. You may visit the following websites:

For downloading of Bidding Documents: <https://www.napocor.gov.ph/bcsd/bids.php>

  
**ATTY. ROGEL T. TEVES**  
Vice President, Power Engineering Services and  
Chairman, Bids and Awards Committee

## SECTION II

# INSTRUCTION TO BIDDERS

## SECTION II - INSTRUCTIONS TO BIDDERS

### TABLE OF CONTENTS

<u>CLAUSE NO.</u>	<u>TITLE</u>	<u>PAGE NO.</u>
1.	SCOPE OF BID .....	1
2.	FUNDING INFORMATION.....	1
3.	BIDDING REQUIREMENTS .....	1
4.	CORRUPT, FRAUDULENT, COLLUSIVE, COERCIVE, AND OBSTRUCTIVE PRACTICES .....	1
5.	ELIGIBLE BIDDERS .....	1
6.	ORIGIN OF ASSOCIATED GOODS.....	2
7.	SUBCONTRACTS.....	2
8.	PRE-BID CONFERENCE .....	2
9.	CLARIFICATION AND AMENDMENT OF BIDDING DOCUMENTS .....	2
10.	DOCUMENTS COMPRISING THE BID: ELIGIBILITY AND TECHNICAL COMPONENTS .....	3
11.	DOCUMENTS COMPRISING THE BID: FINANCIAL COMPONENT .....	3
12.	ALTERNATIVE BIDS .....	3
13.	BID PRICES .....	4
14.	BID AND PAYMENT CURRENCIES .....	4
15.	BID SECURITY.....	4
16.	SEALING AND MARKING OF BIDS .....	4
17.	DEADLINE FOR SUBMISSION OF BIDS .....	4
18.	OPENING AND PRELIMINARY EXAMINATION OF BIDS .....	4
19.	DETAILED EVALUATION AND COMPARISON OF BIDS.....	5
20.	POST QUALIFICATION .....	5
21.	SIGNING OF THE CONTRACT .....	5

## SECTION II - INSTRUCTIONS TO BIDDERS

### 1. Scope of Bid

NPC invites Bids for the **SUPPLY, DELIVERY, INSTALLATION AND TEST OF 1 X 35 KL AND 2 X 60 KL FOST FOR PATNANUNGAN DPP, PALANAN DPP AND JOMALIG DPP INCLUDING CONSTRUCTION OF ASSOCIATED FACILITIES UNDER PACKAGE 1**, with Project Identification Number **LuzP20Z1179Se**.

The Procurement Project (referred to herein as "Project") is for the construction of Works, as described in Section VI (Specifications).

### 2. Funding Information

The GOP through the source of funding as indicated below for CY 2021 in the amount of specified in the Invitation to Bid. The source of funding is the proposed Corporate Operating Budget of the National Power Corporation (NPC).

### 3. Bidding Requirements

The Bidding for the Project shall be governed by all the provisions of RA No. 9184 and its 2016 revised IRR, including its Generic Procurement Manual and associated policies, rules and regulations as the primary source thereof, while the herein clauses shall serve as the secondary source thereof.

Any amendments made to the IRR and other GPPB issuances shall be applicable only to the ongoing posting, advertisement, or invitation to bid by the BAC through the issuance of a supplemental or bid bulletin.

The Bidder, by the act of submitting its Bid, shall be deemed to have inspected the site, determined the general characteristics of the contracted Works and the conditions for this Project, such as the location and the nature of the work; (b) climatic conditions; (c) transportation facilities; (c) nature and condition of the terrain, geological conditions at the site communication facilities, requirements, location and availability of construction aggregates and other materials, labor, water, electric power and access roads; and (d) other factors that may affect the cost, duration and execution or implementation of the contract, project, or work and examine all instructions, forms, terms, and project requirements in the Bidding Documents.

### 4. Corrupt, Fraudulent, Collusive, Coercive, and Obstructive Practices

The Procuring Entity, as well as the Bidders and Contractors, shall observe the highest standard of ethics during the procurement and execution of the contract. They or through an agent shall not engage in corrupt, fraudulent, collusive, coercive, and obstructive practices defined under Annex "I" of the 2016 revised IRR of RA No. 9184 or other integrity violations in competing for the Project.

### 5. Eligible Bidders

- 5.1. Only Bids of Bidders found to be legally, technically, and financially capable will be evaluated.



- 5.2. The Bidder must have an experience of having completed a Single Largest Completed Contract (SLCC) that is similar to this Project, equivalent to at least fifty percent (50%) of the ABC adjusted, if necessary, by the Bidder to current prices using the PSA's CPI, except under conditions provided for in Section 23.4.2.4 of the 2016 revised IRR of RA No. 9184.

A contract is considered to be "similar" to the contract to be bid if it has the major categories of work stated in the **BDS**.

- 5.3. For Foreign-funded Procurement, the Procuring Entity and the foreign government/foreign or international financing institution may agree on another track record requirement, as specified in the Bidding Document prepared for this purpose.

- 5.4. The Bidders shall comply with the eligibility criteria under Section 23.4.2 of the 2016 IRR of RA No. 9184.

## 6. Origin of Associated Goods

There is no restriction on the origin of Goods other than those prohibited by a decision of the UN Security Council taken under Chapter VII of the Charter of the UN.

## 7. Subcontracts

- 7.1. The Bidder may subcontract portions of the Project to the extent allowed by the Procuring Entity as stated herein, but in no case more than fifty percent (50%) of the Project.

- 7.1. The Bidder must submit together with its Bid the documentary requirements of the subcontractor(s) complying with the eligibility criteria stated in **ITB** Clause 5 in accordance with Section 23.4 of the 2016 revised IRR of RA No. 9184 pursuant to Section 23.1 thereof.

- 7.2. Subcontracting of any portion of the Project does not relieve the Contractor of any liability or obligation under the Contract. The Supplier will be responsible for the acts, defaults, and negligence of any subcontractor, its agents, servants, or workmen as fully as if these were the Contractor's own acts, defaults, or negligence, or those of its agents, servants, or workmen.

## 8. Pre-Bid Conference

The Procuring Entity will hold a pre-bid conference for this Project on the specified date and time and either at its physical address and/or through videoconferencing/webcasting) as indicated in paragraph 6 of the **IB**.

## 9. Clarification and Amendment of Bidding Documents

Prospective bidders may request for clarification on and/or interpretation of any part of the Bidding Documents. Such requests must be in writing and received by the Procuring Entity, either at its given address or through electronic mail indicated in the **IB**, at least ten (10) calendar days before the deadline set for the submission and receipt of Bids.

## 10. Documents Comprising the Bid: Eligibility and Technical Components

- 10.1. The first envelope shall contain the eligibility and technical documents of the Bid as specified in **Form NPCSF-INFR-01 - Checklist of Technical and Financial Documents, Section VIII - Bidding Forms.**
- 10.2. If the eligibility requirements or statements, the bids, and all other documents for submission to the BAC are in foreign language other than English, it must be accompanied by a translation in English, which shall be authenticated by the appropriate Philippine foreign service establishment, post, or the equivalent office having jurisdiction over the foreign bidder's affairs in the Philippines. For Contracting Parties to the Apostille Convention, only the translated documents shall be authenticated through an apostille pursuant to GPPB Resolution No. 13-2019 dated 23 May 2019. The English translation shall govern, for purposes of interpretation of the bid.
- 10.3. A valid PCAB License is required, and in case of joint ventures, a valid special PCAB License, and registration for the type and cost of the contract for this Project. Any additional type of Contractor license or permit shall be indicated in the **BDS.**
- 10.4. A List of Contractor's key personnel (e.g., Project Manager, Project Engineers, Materials Engineers, and Foremen) assigned to the contract to be bid, with their complete qualification and experience data shall be provided. These key personnel must meet the required minimum years of experience set in the **BDS.**
- 10.5. A List of Contractor's major equipment units, which are owned, leased, and/or under purchase agreements, supported by proof of ownership, certification of availability of equipment from the equipment lessor/vendor for the duration of the project, as the case may be, must meet the minimum requirements for the contract set in the **BDS.**

## 11. Documents Comprising the Bid: Financial Component

- 11.1. The second bid envelope shall contain the financial documents for the Bid as specified in **Form NPCSF-INFR-01 - Checklist of Technical and Financial Documents, Section VIII - Bidding Forms.**
- 11.2. Any bid exceeding the ABC indicated in paragraph 1 of the **IB** shall not be accepted.
- 11.3. For Foreign-funded procurement, a ceiling may be applied to bid prices provided the conditions are met under Section 31.2 of the 2016 revised IRR of RA No. 9184.

## 12. Alternative Bids

Bidders shall submit offers that comply with the requirements of the Bidding Documents, including the basic technical design as indicated in the drawings and specifications. Unless there is a value engineering clause in the **BDS**, alternative Bids shall not be accepted.

**13. Bid Prices**

All bid prices for the given scope of work in the Project as awarded shall be considered as fixed prices, and therefore not subject to price escalation during contract implementation, except under extraordinary circumstances as determined by the NEDA and approved by the GPPB pursuant to the revised Guidelines for Contract Price Escalation guidelines.

**14. Bid and Payment Currencies**

14.1. Bid prices may be quoted in the local currency or tradeable currency accepted by the BSP at the discretion of the Bidder. However, for purposes of bid evaluation, Bids denominated in foreign currencies shall be converted to Philippine currency based on the exchange rate as published in the BSP reference rate bulletin on the day of the bid opening.

14.2. Payment of the contract price shall be made in Philippine Pesos.

**15. Bid Security**

15.1. The Bidder shall submit a Bid Securing Declaration or any form of Bid Security in the amount indicated in the **BDS**, which shall be not less than the percentage of the ABC in accordance with the schedule in the **BDS**.

15.2. The Bid and bid security shall be valid until **One Hundred Twenty (120) calendar days** from the date of opening of bids. Any bid not accompanied by an acceptable bid security shall be rejected by the Procuring Entity as non-responsive.

**16. Sealing and Marking of Bids**

Each Bidder shall submit one copy of the first and second components of its Bid.

The Procuring Entity may request additional hard copies and/or electronic copies of the Bid. However, failure of the Bidders to comply with the said request shall not be a ground for disqualification.

If the Procuring Entity allows the submission of bids through online submission to the given website or any other electronic means, the Bidder shall submit an electronic copy of its Bid, which must be digitally signed. An electronic copy that cannot be opened or is corrupted shall be considered non-responsive and, thus, automatically disqualified.

**17. Deadline for Submission of Bids**

The Bidders shall submit on the specified date and time and either at its physical address or through online submission as indicated in paragraph 7 of the **IB**.

**18. Opening and Preliminary Examination of Bids**

18.1. The BAC shall open the Bids in public at the time, on the date, and at the place specified in paragraph 9 of the **IB**. The Bidders' representatives who are present shall sign a register evidencing their attendance. In case

videoconferencing, webcasting or other similar technologies will be used, attendance of participants shall likewise be recorded by the BAC Secretariat.

In case the Bids cannot be opened as scheduled due to justifiable reasons, the rescheduling requirements under Section 29 of the 2016 revised IRR of RA No. 9184 shall prevail.

- 18.2. The preliminary examination of Bids shall be governed by Section 30 of the 2016 revised IRR of RA No. 9184.

## 19. Detailed Evaluation and Comparison of Bids

- 19.1. The Procuring Entity's BAC shall immediately conduct a detailed evaluation of all Bids rated "*passed*" using non-discretionary pass/fail criteria. The BAC shall consider the conditions in the evaluation of Bids under Section 32.2 of 2016 revised IRR of RA No. 9184.

- 19.2. If the Project allows partial bids, all Bids and combinations of Bids as indicated in the **BDS** shall be received by the same deadline and opened and evaluated simultaneously so as to determine the Bid or combination of Bids offering the lowest calculated cost to the Procuring Entity. Bid Security as required by **ITB** Clause 15 shall be submitted for each contract (lot) separately.

- 19.3. In all cases, the NFCC computation pursuant to Section 23.4.2.6 of the 2016 revised IRR of RA No. 9184 must be sufficient for the total of the ABCs for all the lots participated in by the prospective Bidder.

## 20. Post Qualification

Within a non-extendible period of five (5) calendar days from receipt by the Bidder of the notice from the BAC that it submitted the Lowest Calculated Bid, the Bidder shall submit its latest income and business tax returns filed and paid through the BIR Electronic Filing and Payment System (eFPS), and other appropriate licenses and permits required by law and stated in the **BDS**.

## 21. Signing of the Contract

The documents required in Section 37.2 of the 2016 revised IRR of RA No. 9184 shall form part of the Contract. Additional Contract documents are indicated in the **BDS**.

## SECTION III - BID DATA SHEET

ITB Clause	
5.2	<p>For this purpose, contracts similar to the Project refer to contracts which have the same major categories of work, which shall to construction of Fuel Oil Storage Tank, including its concrete foundation and associated works with capacity of not less 35 cu.m.</p> <p>The Single Largest Completed Contract (SLCC) as declared by the bidder shall be verified and validated to ascertain such completed contract. Hence, bidders must ensure access to sites of such projects/equipment to NPC representatives for verification and validation purposes during post-qualification process.</p> <p>It shall be a ground for disqualification, if verification and validation cannot be conducted for reasons attributable to the Bidder.</p>
7.1	<p>Only a maximum of fifty percent (50%) of the Works may be subcontracted. All Subcontractors must be approved by NPC.</p>
10.1	<p>The list of on-going contracts (Form No. NPCSF-INFR-02) shall be supported by the following documents for each on-going contract to be submitted during Post-Qualification:</p> <ol style="list-style-type: none"> <li>1. Contract/Purchase Order and/or Notice of Award</li> <li>2. Certification coming from the project owner/client that the performance is satisfactory as of the bidding date.</li> </ol> <p>The bidder shall declare in this form all his on-going government and private contracts including contracts where the bidder (either as individual or as a Joint Venture) is a partner in a Joint Venture agreement other than his current joint venture where he is a partner. Non declaration will be a ground for disqualification of bid.</p>
	<p>The Statement of the bidder's Single Largest Completed Contract (SLCC) similar to the contract to be bid (Form No. NPCSF-INFR-03) shall be supported by the following documents to be submitted during Bid Opening:</p> <ol style="list-style-type: none"> <li>1. Contract/Purchase Order</li> <li>2. Owner's Certificate of Final Acceptance issued by the project owner other than the contractor or a final rating of at least Satisfactory in the Constructors Performance Evaluation System (CPES). In case of contracts with the private sector, an equivalent document (Ex. Official Receipt or Sales Invoice) shall be submitted.</li> </ol>
10.3	<p>The required License issued by the Philippine Contractors Accreditation Board (PCAB): License Category of at least <b>"CATEGORY D – GENERAL BUILDING"</b> and registration classification of at least <b>"SMALL B – BUILDING AND INDUSTRIAL PLANT"</b> OR at least <b>"SMALL B – MECHANICAL WORK"</b></p>

<p>10.4</p>	<p>The list of key personnel shall include the following minimum requirements:</p> <p><b>a. One (1) Project/Site Engineer</b> Registered Civil Engineer who had supervised at least a project similar in nature as to the type of the proposed project within the last 10 years. Must have 3 years professional as Civil Engineer on similar project</p> <p><b>b. One (1) Safety Officer 2</b> Construction Safety Officer who has completed at least forty (40) hours of Construction Safety and Health Training (COSH) from Occupational Safety and Health Center (OSHC) or Safety Training Organizations (STOs) accredited by the Department of Labor and Employment (DOLE)</p> <p>Valid Professional Regulations Commission (PRC) license for professional personnel, Construction Safety and Health Training Certificate from OSHC/STOs accredited by DOLE for the Safety Officer, shall be submitted and included as an attachment in the Standard Form NPCSF-INFR-09: List of Key Personnel Proposed to be Assign to the Contract.</p> <p>The above key personnel must either be employed by the Bidder or contracted by the Bidder to be employed for the contract to be bid.</p>																
<p>10.5</p>	<p>The list of construction equipment (owned or leased) shall include the following minimum requirements:</p> <table border="0"> <tr> <td>a. Welding Machine (300 A min)</td> <td>- 2 units</td> </tr> <tr> <td>b. Bar cutter (32mm ø capable)</td> <td>- 1 unit</td> </tr> <tr> <td>c. Concrete Mixer (1 bagger)</td> <td>- 2 units</td> </tr> <tr> <td>d. Oxy-acetylene cutting outfit</td> <td>- 1 unit</td> </tr> <tr> <td>e. Water Truck (500 Gal. cap)</td> <td>- 1 unit</td> </tr> <tr> <td>f. Concrete Vibrator (3.5HP)</td> <td>- 1 unit</td> </tr> <tr> <td>g. Vibratory Plate Compactor</td> <td>- 1 unit</td> </tr> <tr> <td>h. Cargo Truck</td> <td>- 1 unit</td> </tr> </table>	a. Welding Machine (300 A min)	- 2 units	b. Bar cutter (32mm ø capable)	- 1 unit	c. Concrete Mixer (1 bagger)	- 2 units	d. Oxy-acetylene cutting outfit	- 1 unit	e. Water Truck (500 Gal. cap)	- 1 unit	f. Concrete Vibrator (3.5HP)	- 1 unit	g. Vibratory Plate Compactor	- 1 unit	h. Cargo Truck	- 1 unit
a. Welding Machine (300 A min)	- 2 units																
b. Bar cutter (32mm ø capable)	- 1 unit																
c. Concrete Mixer (1 bagger)	- 2 units																
d. Oxy-acetylene cutting outfit	- 1 unit																
e. Water Truck (500 Gal. cap)	- 1 unit																
f. Concrete Vibrator (3.5HP)	- 1 unit																
g. Vibratory Plate Compactor	- 1 unit																
h. Cargo Truck	- 1 unit																
<p>10.6</p>	<p>Bidders shall also submit the following requirements in their first envelope, Eligibility and Technical Component of their bid:</p> <p>1. Duly signed and completely filled up Technical Data Sheets for Mechanical Works (Section VI – Part II MW)</p> <p>Manufacturer's brochures, manuals and other supporting documents of equipment, materials, hardware and tools proposed by the bidders must comply with the technical specifications of such equipment, materials, hardware and tools. It shall be a ground for disqualification if the submitted brochures, manuals and other supporting documents are determined not complying with the specifications during technical evaluation and post-qualification process.</p> <p>Equipment, materials, hardware and tools proposed by the winning bidder to be supplied, which were evaluated to be complying with the technical specifications, shall not be replaced and must be the same items to be delivered/installed/used during the contract implementation. Any proposed changes/replacement of said items may be allowed on meritorious reasons subject to validation and prior approval by NPC.</p> <p>2. Complete eligibility documents of the proposed sub-contractor, if any</p>																

	<p>Equipment, materials, hardware and tools proposed by the winning bidder to be supplied, which were evaluated to be complying with the technical specifications, shall not be replaced and must be the same items to be delivered/installed/used during the contract implementation. Any proposed changes/replacement of said items may be allowed on meritorious reasons subject to validation and prior approval by NPC.</p> <p>2. Complete eligibility documents of the proposed sub-contractor, if any</p>
10.7	<p>The prospective bidders shall declare its Joint Venture partner during the purchase of bid/tender documents. Any single bidder/s who already procured/secured the bidding documents but want to avail the Joint Venture Agreement (JVA) shall inform the BAC in writing prior to the bid opening for records and documentation purposes. Failure to do so shall be a ground for disqualification/non-acceptance of its bid.</p>
12	<p>No further instructions</p>
15.1	<p>The bid security shall be in the form of a Bid Securing Declaration or any of the following forms and amounts:</p> <ol style="list-style-type: none"> <li>1. The amount of not less than 2% of ABC, if bid security is in cash, cashier's/manager's check, bank draft/guarantee or irrevocable letter of credit;</li> <li>2. The amount of not less than 5% of ABC if bid security is in Surety Bond.</li> </ol>
19.2	<p>Partial Bid is not allowed. The project is grouped in a single lot and the lot shall not be divided into sub-lots for the purpose of bidding, evaluation, and contract award.</p>
20	<ol style="list-style-type: none"> <li>a. Contract/Purchase Order and/or Notice of Award for the contracts stated in the List of all Ongoing Government &amp; Private Contracts Including Contracts Awarded but not yet Started (NPCSF-INFR-02);</li> <li>b. Certification coming from the project owner/client that the performance is satisfactory as of the bidding date for all ongoing contracts stated in form NPCSF-INFR-02.</li> <li>c. The licenses and permits relevant to the Project and the corresponding law requiring it as specified in the Technical Specifications, if any.</li> </ol>
21	<p>The following documents shall form part of the contract:</p> <ol style="list-style-type: none"> <li>1. Notice to Proceed</li> <li>2. Construction schedule and S-curve</li> <li>3. Manpower Schedule</li> <li>4. Construction Methods</li> <li>5. Equipment Utilization Schedule</li> <li>6. Construction safety and health program of the contractor duly approved by the Bureau of Working Condition (BWC) of the Department of Labor and Employment (DOLE) or proof of submission to BWC</li> <li>7. PERT/CPM.</li> </ol>

## **SECTION IV**

# **GENERAL CONDITIONS OF CONTRACT**



## SECTION IV – GENERAL CONDITIONS OF CONTRACT

### TABLE OF CONTENTS

<u>CLAUSE NO.</u>	<u>TITLE</u>	<u>PAGE NO.</u>
1.	SCOPE OF CONTRACT .....	1
2.	SECTIONAL COMPLETION OF WORKS .....	1
3.	POSSESSION OF SITE .....	1
4.	THE CONTRACTOR'S OBLIGATIONS .....	1
5.	PERFORMANCE SECURITY .....	2
6.	SITE INVESTIGATION REPORTS .....	2
7.	WARRANTY .....	2
8.	LIABILITY OF THE CONTRACTOR .....	2
9.	TERMINATION FOR OTHER CAUSES .....	2
10.	DAYWORKS .....	2
11.	PROGRAM OF WORK .....	3
12.	INSTRUCTIONS, INSPECTIONS AND AUDITS .....	3
13.	ADVANCE PAYMENT .....	3
14.	PROGRESS PAYMENTS .....	3
15.	OPERATING AND MAINTENANCE MANUALS .....	3

## SECTION IV – GENERAL CONDITIONS OF CONTRACT

### 1. Scope of Contract

This Contract shall include all such items, although not specifically mentioned, that can be reasonably inferred as being required for its completion as if such items were expressly mentioned herein. All the provisions of RA No. 9184 and its 2016 revised IRR, including the Generic Procurement Manual, and associated issuances, constitute the primary source for the terms and conditions of the Contract, and thus, applicable in contract implementation. Herein clauses shall serve as the secondary source for the terms and conditions of the Contract.

This is without prejudice to Sections 74.1 and 74.2 of the 2016 revised IRR of RA No. 9184 allowing the GPPB to amend the IRR, which shall be applied to all procurement activities, the advertisement, posting, or invitation of which were issued after the effectivity of the said amendment.

### 2. Sectional Completion of Works

If sectional completion is specified in the **Special Conditions of Contract (SCC)**, references in the Conditions of Contract to the Works, the Completion Date, and the Intended Completion Date shall apply to any Section of the Works (other than references to the Completion Date and Intended Completion Date for the whole of the Works).

### 3. Possession of Site

3.1 The Procuring Entity shall give possession of all or parts of the Site to the Contractor based on the schedule of delivery indicated in the **SCC**, which corresponds to the execution of the Works. If the Contractor suffers delay or incurs cost from failure on the part of the Procuring Entity to give possession in accordance with the terms of this clause, the Procuring Entity's Representative shall give the Contractor a Contract Time Extension and certify such sum as fair to cover the cost incurred, which sum shall be paid by Procuring Entity.

3.2 If possession of a portion is not given by the above date, the Procuring Entity will be deemed to have delayed the start of the relevant activities. The resulting adjustments in contract time to address such delay may be addressed through contract extension provided under Annex "E" of the 2016 revised IRR of RA No. 9184.

### 4. The Contractor's Obligations

The Contractor shall employ the key personnel named in the Schedule of Key Personnel indicating their designation, in accordance with ITB Clause 10.3 and specified in the **BDS**, to carry out the supervision of the Works.

The Procuring Entity will approve any proposed replacement of key personnel only if their relevant qualifications and abilities are equal to or better than those of the personnel listed in the Schedule.

## 5. Performance Security

- 5.1. Within ten (10) calendar days from receipt of the Notice of Award from the Procuring Entity but in no case later than the signing of the contract by both parties, the successful Bidder shall furnish the performance security in any of the forms prescribed in Section 39 of the 2016 revised IRR.
- 5.2. The Contractor, by entering into the Contract with the Procuring Entity, acknowledges the right of the Procuring Entity to institute action pursuant to RA No. 3688 against any subcontractor be they an individual, firm, partnership, corporation, or association supplying the Contractor with labor, materials and/or equipment for the performance of this Contract.

## 6. Site Investigation Reports

The Contractor, in preparing the Bid, shall rely on any Site Investigation Reports referred to in the SCC supplemented by any information obtained by the Contractor.

## 7. Warranty

- 7.1. In case the Contractor fails to undertake the repair works under Section 62.2.2 of the 2016 revised IRR, the Procuring Entity shall forfeit its performance security, subject its property(ies) to attachment or garnishment proceedings, and perpetually disqualify it from participating in any public bidding. All payables of the GOP in his favor shall be offset to recover the costs.
- 7.2. The warranty against Structural Defects/Failures, except that occasioned-on force majeure, shall cover the period from the date of issuance of the Certificate of Final Acceptance by the Procuring Entity. Specific duration of the warranty is found in the SCC.

## 8. Liability of the Contractor

Subject to additional provisions, if any, set forth in the SCC, the Contractor's liability under this Contract shall be as provided by the laws of the Republic of the Philippines.

If the Contractor is a joint venture, all partners to the joint venture shall be jointly and severally liable to the Procuring Entity.

## 9. Termination for Other Causes

Contract termination shall be initiated in case it is determined *prima facie* by the Procuring Entity that the Contractor has engaged, before, or during the implementation of the contract, in unlawful deeds and behaviors relative to contract acquisition and implementation, such as, but not limited to corrupt, fraudulent, collusive, coercive, and obstructive practices as stated in ITB Clause 4.

## 10. Dayworks

Subject to the guidelines on Variation Order in Annex "E" of the 2016 revised IRR of RA No. 9184, and if applicable as indicated in the SCC, the Dayworks rates in the Contractor's Bid shall be used for small additional amounts of work only when the

Procuring Entity's Representative has given written instructions in advance for additional work to be paid for in that way.

## 11. Program of Work

11.1. The Contractor shall submit to the Procuring Entity's Representative for approval the said Program of Work showing the general methods, arrangements, order, and timing for all the activities in the Works. The submissions of the Program of Work are indicated in the SCC.

11.2. The Contractor shall submit to the Procuring Entity's Representative for approval an updated Program of Work at intervals no longer than the period stated in the SCC. If the Contractor does not submit an updated Program of Work within this period, the Procuring Entity's Representative may withhold the amount stated in the SCC from the next payment certificate and continue to withhold this amount until the next payment after the date on which the overdue Program of Work has been submitted.

## 12. Instructions, Inspections and Audits

The Contractor shall permit the GOP or the Procuring Entity to inspect the Contractor's accounts and records relating to the performance of the Contractor and to have them audited by auditors of the GOP or the Procuring Entity, as may be required.

## 13. Advance Payment

The Procuring Entity shall, upon a written request of the Contractor which shall be submitted as a Contract document, make an advance payment to the Contractor in an amount not exceeding fifteen percent (15%) of the total contract price, to be made in lump sum, or at the most two installments according to a schedule specified in the SCC, subject to the requirements in Annex "E" of the 2016 revised IRR of RA No. 9184.

## 14. Progress Payments

The Contractor may submit a request for payment for Work accomplished. Such requests for payment shall be verified and certified by the Procuring Entity's Representative/Project Engineer. Except as otherwise stipulated in the SCC, materials and equipment delivered on the site but not completely put in place shall not be included for payment.

## 15. Operating and Maintenance Manuals

15.1. If required, the Contractor will provide "as built" Drawings and/or operating and maintenance manuals as specified in the SCC.

15.2. If the Contractor does not provide the Drawings and/or manuals by the dates stated above, or they do not receive the Procuring Entity's Representative's approval, the Procuring Entity's Representative may withhold the amount stated in the SCC from payments due to the Contractor.

## **SECTION V**

# **SPECIAL CONDITIONS OF CONTRACT**

**SECTION V – SPECIAL CONDITIONS OF CONTRACT**

GCC Clause	
2	Sectional completion is not specified.
4	<p>It shall also be the obligation and responsibility of the Contractor to carry out the Works properly and in accordance with this Contract, including but not limited to the following conditions:</p> <p>a. The Contractor shall conduct the Works with due regard to safety and health in accordance with its Construction Safety and Health Program (CSHP) duly approved by the Department of Labor &amp; Employment (DOLE) and in compliance with the DOLE Department Order No. 13 – The Guidelines Governing Occupational Safety and Health in the Construction Industry.</p> <p>Failure to comply with the approved CSHP will be considered as non-compliance with the Contract and shall result to the imposition of Section 19, Violation and Penalties of the DOLE Department Order No. 13 and any appropriate sanctions such as, but not limited to:</p> <ol style="list-style-type: none"> <li>1. Suspend the work until the Contractor complies with the approved CSHP with the condition that the work resumption will not incur additional cost to the Corporation;</li> <li>2. Suspend payment of the portion of work under question;</li> <li>3. Correct the situation by employing 3<sup>rd</sup> party and charge all expenses incurred to the Contractor’s collectibles/securities; and</li> <li>4. Report the condition to the Bureau of Working Conditions of the DOLE for their appropriate action.</li> </ol> <p>b. The Contractor shall be responsible for the strict compliance with the provision of the Philippine Laws affecting labor and operation of Work under the contract and shall be responsible for the payment of all indemnities arising out of any labor accident which may occur in the execution of the Works and for which he may be responsible under Republic Act 3428, as amended, known as the Workmen’s Compensation Law.</p> <p>c. The Contractor is obliged to exercise due care so as not to endanger life and property in the vicinity of the Works where he operates in connection with this Contract. He shall be liable for all damages incurred in any manner by acts of negligence of his own, or his agents, employees, or workmen.</p> <p>d. It is the responsibility of the Contractor for the strict compliance with the requirements of the Philippine Clean Air Act of 1999 (R.A. 8749) and Philippine Clean Water Act of 2004 (R.A. 9275). The Contractor shall be liable for any damages/destructions to the environment including penalties that will be imposed by the Department of Environment and Natural Resources (DENR) arising from non-compliance of the requirements thereof.</p>



SECTION V – SPECIAL CONDITIONS OF CONTRACT

LuzP20Z1179Se

	<p>e. The Contractor shall be responsible for the strict compliance with the requirements of the Environmental Compliance Certificate (ECC) issued for this project (if any) and DENR Administrative Order No. 26. He shall be liable for any damages/destructions to the environment including penalties that will be imposed by the DENR arising from non-compliance thereof, in any manner by his acts or negligence, or by his agents, employees, or workmen in the execution of the Works. The Contractor may employ a Pollution Control Officer accredited with the DENR for the duration of the project, if so required by the DENR Administrative Order No. 26</p> <p>f. It shall be the Contractor's responsibility for the correctness, accuracy and quality of works. NPC's approval does not relieve his contractual obligation and responsibility under this contract.</p> <p>g. Payment of all forms of taxes, such as value added tax (VAT) including municipal licenses and permits, and others that may be imposed by the Philippine Government or any of its agencies and political subdivisions in connection with the Contract shall be for the account of the Contractor.</p> <p>h. In general, the Contractor is totally responsible for the execution of the Works and therefore, takes upon himself all the technical, legal and economic risks and all obligations which could arise therefrom or connected therewith. The overall responsibility of the Contractor includes the responsibility for actions or omissions of his own personnel as well as the personnel of the sub-contractors.</p>
<p>4.1</p>	<p>NPC shall give access to the Site for the Contractor to commence and proceed with the works on the start date. The access to the site referred herein shall not be exclusive to the Contractor but only to enable him to execute the Work.</p>
<p>5</p>	<p>1. The following must be indicated in the performance bond to be posted by the Contractor:</p> <ul style="list-style-type: none"> <li>i. Company Name</li> <li>ii. Correct amount of the Bond</li> <li>iii. Contract/Purchase Order Reference Number</li> <li>iv. Purpose of the Bond:                      "To guarantee the faithful performance of the Principal's obligation to undertake <u>(Contract/Purchase Order Description)</u> in accordance with the terms and conditions of <u>(Contract No. &amp; Schedule/Purchase Order No.)</u> entered into by the parties."</li> </ul> <p>2. The bond shall remain valid and effective until the duration of the contract <u>(should be specific date reckoned from the contract effectivity)</u> plus sixty (60) days after NPC's acceptance of the last delivery/final acceptance of the project.</p> <p>3. In case of surety bond, any extension of the contract duration or delivery period granted to the CONTRACTOR shall be considered as given, and any modification of the contract shall be considered as authorized, as if with the expressed consent of the surety, provided that such extension or modifications falls within the effective period</p>



	<p>of the said surety bond. However, in the event that the extension of the contract duration or delivery schedule would be beyond the effective period of the surety bond first posted, it shall be the sole obligation of the CONTRACTOR to post an acceptable Performance Security within ten (10) calendar days after the contract duration/delivery period extension has been granted by NPC.</p> <p>4. Other required conditions in addition to the standard policy terms issued by the Bonding Company:</p> <ul style="list-style-type: none"> <li>i. The bond is a penal bond, callable on demand and the entire amount thereof shall be forfeited in favor of the Obligee upon default of the Principal without the need to prove or to show grounds or reasons for demand for the sum specified therein;</li> <li>ii. The amount claimed by the Obligee under this bond shall be paid in full and shall never be subject to any adjustment by the Surety;</li> <li>iii. In case of claim, the Surety shall pay such claim within sixty (60) days from receipt by the Surety of the Obligee's notice of claim/demand letter notwithstanding any objection thereto by the Principal.</li> </ul>
6	No site investigation report.
7.2	<p>In case of permanent structures, such as buildings of types 4 and 5 as classified under the National Building Code of the Philippines and other structures made of steel, iron, or concrete which comply with relevant structural codes (e.g., DPWH Standard Specifications), such as, but not limited to, steel/concrete bridges, flyovers, aircraft movement areas, ports, dams, tunnels, filtration and treatment plants, sewerage systems, power plants, transmission and communication towers, railway system, and other similar permanent structures: Fifteen (15) years.</p> <p>In case of semi-permanent structures, such as buildings of types 1, 2, and 3 as classified under the National Building Code of the Philippines, concrete/asphalt roads, concrete river control, drainage, irrigation lined canals, river landing, deep wells, rock causeway, pedestrian overpass, and other similar semi-permanent structures: Five (5) years.</p> <p>In case of other structures, such as Bailey and wooden bridges, shallow wells, spring developments, and other similar structures: Two (2) years.</p>
10	No dayworks are applicable to the contract.
11.1	The Contractor shall submit the Program of Work to the Procuring Entity's Representative within Ten (10) calendar days of delivery of the Notice of Award/Letter of Acceptance.
11.2	<p>The period between Program of Work updates is Thirty (30) calendar days.</p> <p>The amount to be withheld for late submission of an updated Program of Work is One percent (1%) of contract amount.</p>



<p>12</p>	<p>During contract implementation, the Procuring Entity shall conduct Constructors Performance Evaluation in accordance with Section 12, Annex E of the Revised Implementing Rules and Regulation of R.A. 9184 using the NPC Constructors Performance Evaluation System (CPES) Guidelines.</p> <p>CPES ratings shall be used for the following purposes: a) eligibility screening/post-qualification; b) awarding of contracts; c) project monitoring &amp; control; d) issuance of Certificate of Completion; and in adopting measures to further improve performance of contractors in the prosecution of government projects.</p> <p>Qualified Constructors Performance Evaluators (CPE) shall conduct project evaluation as follows:</p> <p>(a) During Construction - Except for those projects with a duration of 90 calendar days and below which may be subjected to at least one (1) visit, all projects shall be subjected to a minimum of two (2) evaluations to be performed by the CPE. The number of evaluations beyond the prescribed minimum shall be determined by the CPES-Implementing Unit based on the size, nature and complexity of the project and shall be subject to approval by the proper authorities within the agency. The first evaluation shall be performed when the project is at least thirty percent (30%) physically complete or as maybe required by the CPES-IU using the S-curve or other appropriate means to determine whether there is substantial work completed for evaluation.</p> <p>(b) Upon Completion - only one evaluation shall be performed by the CPE right after the Project Implementation Group reports one hundred percent (100%) completion of the project.</p>
<p>13</p>	<p>The maximum amount of advance payment is fifteen percent (15%) of the Contract Price and paid in lump sum.</p>
<p>14</p>	<p>No further instructions.</p>
<p>15.1</p>	<p>The date by which "as built" drawings and operating and maintenance manuals are required is within thirty (30) calendar days after completion of contract.</p>
<p>15.2</p>	<p>The amount to be withheld for failing to produce "as built" drawings and/or operating and maintenance manuals by the date required is Five percent (5%) of contract amount.</p>

## SECTION VI

# TECHNICAL SPECIFICATIONS

## (PART I – TECHNICAL SPECIFICATIONS)

- GW** – General Works
- AW** – Architectural Works
- CW** – Civil Works
- MW** – Mechanical Works
- EW** – Electrical Works

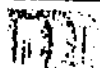

# PART I

# TECHNICAL SPECIFICATIONS

## GW - GENERAL WORKS

**PART 1 - TECHNICAL SPECIFICATIONS**

**GW – GENERAL WORKS**

**TABLE OF CONTENTS**

<u>CLAUSE NO.</u>	<u>TITLE</u>	<u>PAGE NO.</u>
<b>GW-1.0</b>	<b>GENERAL.....</b>	<b>1</b>
GW-1.1	Project Description.....	1
GW-1.2	Project Location.....	2
GW-1.3	Project Duration.....	2
GW-1.4	Contractor's Classification .....	2
GW-1.5	Minimum Required Key Personnel.....	2
GW-1.6	Minimum Required Construction Equipment.....	2
<b>GW-2.0</b>	<b>SCOPE OF WORK.....</b>	<b>3</b>
<b>GW-3.0</b>	<b>MATERIALS AND EQUIPMENT.....</b>	<b>5</b>
GW-3.1	General.....	5
GW-3.2	Codes and Standards .....	5
GW-3.3	Test of Materials .....	6
GW-3.4	Tropical Serviceability.....	6
GW-3.4.1	General.....	6
GW-3.4.2	Metals.....	6
GW-3.5	Workmanship.....	7
<b>GW-4.0</b>	<b>DESIGN AND DUTY CONDITIONS .....</b>	<b>7</b>
GW-4.1	Acknowledgement to Site Conditions.....	7
GW-4.2	Site Conditions .....	7
GW-4.3	Earthquake and Wind Design Requirements .....	7
GW-4.4	Sound Control.....	8
<b>GW-5.0</b>	<b>EQUIPMENT MARKING, LABELING AND MISCELLANEOUS REQUIREMENTS.....</b>	<b>8</b>
GW-5.1	Identification System.....	8
GW-5.2	Nameplates and Labels .....	9
GW-5.3	Erection Marks.....	10
GW-5.4	Guards.....	10
GW-5.5	Lifting Lugs .....	10
<b>GW-6.0</b>	<b>DRAWINGS.....</b>	<b>10</b>
GW-6.1	Drawings Contained in the Tender Document.....	10
GW-6.2	Contractor/Manufacturer Drawings .....	11
GW-6.2.1	General.....	11
GW-6.2.2	As-Built Drawings .....	12
GW-6.2.3	Processing of Drawings .....	13
GW-6.3	Documents for NPC's Records .....	14
<b>GW-7.0</b>	<b>INSPECTION AND TESTS.....</b>	<b>14</b>
GW-7.1	General.....	14
GW-7.2	Inspection/Tests at Contractor's Premises.....	15

GW-7.3	Site Test .....	15
GW-7.4	Tests Failures .....	16
GW-7.5	Test Reports/Certificates .....	16
<b>GW-8.0</b>	<b>QUALITY ASSURANCE REQUIREMENTS .....</b>	<b>16</b>
GW-8.1	General.....	16
GW-8.2	Quality Assurance Program .....	16
GW-8.3	Quality Plan .....	17
GW-8.4	Records .....	17
GW-8.5	Reporting and Corrective Action .....	17
<b>GW-9.0</b>	<b>DEMOLITION AND RELOCATION OF EXISTING EQUIPMENT AND STRUCTURES .....</b>	<b>18</b>
GW-9.1	General.....	18
GW-9.2	Dismantling of Existing Installations .....	18
GW-9.3	Storage, Transportation and Re-Erection.....	18
GW-9.4	Demolition.....	18
GW-9.5	Disposal of Demolished Materials.....	19
<b>GW-10.0</b>	<b>CORROSION PROTECTION AND PAINTING .....</b>	<b>19</b>
GW-10.1	General.....	19
GW-10.2	Treatment for Shipping .....	20
GW-10.3	Application of Paint.....	20
GW-10.4	Hot Dip Galvanizing .....	22
<b>GW-11.0</b>	<b>PACKING, SHIPMENT AND STORAGE.....</b>	<b>22</b>
GW-11.1	Preparation .....	22
GW-11.2	Shipment/Transport .....	24
GW-11.3	Storage.....	24
<b>GW-12.0</b>	<b>CLEAN UP .....</b>	<b>25</b>
<b>GW-13.0</b>	<b>CERTIFICATE OF COMPLETION AND ACCEPTANCE .....</b>	<b>25</b>
<b>GW-14.0</b>	<b>GUARANTEE.....</b>	<b>25</b>
<b>GW-15.0</b>	<b>MEASUREMENT OF PAYMENT .....</b>	<b>26</b>

## PART I - TECHNICAL SPECIFICATIONS

### GW – GENERAL WORKS

#### GW-1.0 GENERAL

#### GW-1.1 Project Description

This section covers the general technical requirements for furnishing of all supervision, equipment, labor, materials, supplies, tools and other incidentals in accordance with the specifications herein and shown on the accompanying drawings for the following:

- a. Supply, delivery, installation and test, of 1 X 35 kL Fuel Oil Storage Tank and Auxiliary Equipment/Accessories including Construction of Associated Facilities for Patnanungan DPP; and
- b. Supply, delivery, installation and test of 2 X 60 kL Fuel Oil Storage Tank and Auxiliary Equipment/Accessories including Construction of Associated Facilities for Palanan DPP and Jomalig DPP

The new Fuel Oil Storage Tank (FOST) and associated auxiliaries and facilities shall serve as storage and transfer system of diesel oil and for use of the existing generating sets at Palanan DPP in Isabela and, Patnanungan DPP and Jomalig DPP in Quezon.

The work shall include all and every work and service although not specifically detailed herein but are required to fully complete and placing ready for the safe and reliable operation of the FOST, Auxiliary Equipment/Accessories and Associated Facilities.

The work shall be performed and completed with high quality workmanship in accordance with all applicable codes, standards and generally accepted modern practice in the fabrication, installation and test of the Fuel Oil Storage Tank, Auxiliary Equipment/Accessories and Associated Facilities.

All necessary corrections and deviations from the specification of the equipment and materials arising either from error in the workmanship or design made by the manufacturer with the resulting extra expenses and related damages shall be solely charged to the account of the Contractor.

The Contractor shall strictly observe the general requirements of this specification (General Works) in conjunction with the specific technical requirements specified in the relevant specifications (Mechanical, Civil & Electrical Works). The specific technical specifications shall take precedence over the General Technical Requirements in case of any inconsistency.

**GW-1.2 Project Location**

The FOST and auxiliary equipment/accessories to be fabricated and supplied by the Contractor shall be delivered, installed and tested at existing Palanan DPP, Patnanungan DPP and Jomalig DPP located in the province of Isabela and Quezon, respectively.

EXISTING MODE OF TRANSPORT FROM PORT OF MANILA		
PLANT	1	2
Palanan DPP, Brgy. Culasi, Palanan, Isabela	Port of Manila - Palanan DPP L	
Patnanungan DPP, Brgy. Poblacion, Patnanungan, Quezon Province	Port of Manila - Real Port L	Real Port – Patnanungan Island SS
Jomalig DPP, Brgy. Talisoy, Jomalig, Quezon Province	Port of Manila - Real Port L	Real Port – Jomalig Island SS
<i>NOTES: L – Land Travel; S – Sea Travel; S-S – Special Trip Sea Travel</i>		

**GW-1.3 Project Duration**

The work duration of the project is Two Hundred Forty (240) Calendar Days which shall become effective from receipt of Notice to Proceed. The total contract period is inclusive of twenty (20) rainy/unworkable days, considered unfavorable for the execution of works at site.

**GW-1.4 Contractor’s Classification**

PCAB license category of at least **Category D – General Building** with inter-agency classification of at least **Small B – Building and Industrial Plant** or **Small B – Mechanical Works**.

**GW-1.5 Minimum Required Key Personnel**

- a) One (1) Project/Site Engineer – Registered Civil Engineer who had supervised at least a project similar in nature as to the type of proposed project within the last ten years. Must have 3 years professional as Civil Engineer on similar project.
- b) One (1) Safety Officer 2 –Construction Safety Officer who has completed at least forty (40) hours of Construction Safety and Health Training (COSH) from Occupational Safety and Health Center (OSHC) or safety Training Organizations (STOs) accredited by the Department of Labor and Employment (DOLE).

**GW-1.6 Minimum Required Construction Equipment**

- a) Welding Machine (300 Amp) - 2 units
- b) Bar Cutter (32mm Ø capable) - 1 unit
- c) Concrete Mixer (1-bagger) - 2 units
- d) Oxy-acetylene Gas Cutter - 1 unit
- e) Water Truck (500 gal. cap.) - 1 unit
- f) Concrete Vibrator (3.5 hp) - 1 unit
- g) Vibratory Plate Compactor - 1 unit
- h) Cargo Truck - 1 unit

**GW-2.0 SCOPE OF WORK**

It is not the intent of this specification to specify all technical requirements or to set forth those requirements covered by applicable codes and standards. The Contractor shall furnish high quality work, materials and equipment meeting the requirements of this specification and industry standards.

The Contractor shall also be responsible to assess and determine all and every work and service although not specifically detailed but are deemed required to fully complete the work and placing ready for the safe and reliable operation of the fuel oil storage tank and associated equipment. Relative costs of any additional works or materials which the Contractor deemed required or necessary to complete the works shall be included in the bid proposal.

Any discrepancies of the scope of work specified in this section with those specified in the relevant specific technical specifications (Mechanical, Electrical and Civil Works), the specific technical specifications shall govern. However, anything mentioned in the specific technical specifications and not shown on the drawings, or shown in the drawings but not mentioned in the specifications but which are obviously necessary to make a complete installation shall be considered under the Contractor's Scope of Works.

The work to be done under this section shall comprise the furnishing of all labor, tools, equipment, supply of appurtenant materials and other incidentals to complete and make ready all the works enumerated hereunder in accordance with the Specifications contained herein and as shown in the drawings or otherwise directed by the NPC, which shall consist of but not limited to the following:

- a) Mobilization/establishment of Contractor's complete construction camp and other facilities;
- b) Site development/grading works, clearing/cutting of trees, disposal of excavated and excess material from backfill/fill in the areas to be designated by NPC;
- c) Supply, fabrication, erection/installation and test of 1 X 35 kL FOST with nominal diameter of 3.0 m and height of 5.4 m complete with valves, all tank appurtenances and accessories shown on the drawings and specified in relevant specifications including tank calibration, testing (liquid penetrant & hydrostatic), sandblasting and painting;
- d) Supply, fabrication, erection/installation and test of 2 x 60 M<sup>3</sup> Fuel Oil Storage Tank with nominal diameter of 3.6 m and height of 6.1 m complete with valves, all tank appurtenances and accessories shown on the drawings and specified in relevant specifications including tank calibration, testing (liquid penetrant & hydrostatic), sandblasting and painting;



- e) Supply, installation and test of one (1) set 10 m<sup>3</sup>/hr at 30m head Fuel Oil Transfer Pump, 240V, 1-phase, 60 hertz, gear type complete with piping, fittings, valves, strainers, flow meter, electrical amenities, control & instrumentation, concrete foundation and other accessories described in this specification – **for each Plant;**
- f) Construction of fuel pump house complete with electrical amenities and concrete foundation for fuel oil transfer pump – **for Patnanungan DPP and Jomalig DPP;**
- g) Renovation/rehabilitation of existing guard house to fuel pumphouse – **for Palanan DPP;**
- h) Construction of oil-water separator – **for Palanan DPP and Jomalig DPP;**
- i) Construction of concrete foundation for the FOST, concrete slab in tank farm and its concrete containment walls and posts including drain pits and valve boxes;
- j) Supply, installation and test of one (1) lot fuel oil pipes/waste oil, pipe fittings, pipe supports, associated valves and accessories, required excavation and backfilling works, interconnection works with existing fuel piping system and drainage systems as shown on the drawings;
- k) Supply and installation of three (3) sets of Foam (AFFF) wheeled type fire extinguisher, complete with self-contained cylinder mounted on a frame with handle, floor stand and steel wheels, 125 L (33 gallons) capacity complete with associated valves, dial gauge indicator, nitrogen expellant tank for unit pressurization, appropriate size of discharge hose of 15 m long fitted with couplings and foam nozzle assembly;
- l) Supply and installation of three (3) units of Portable Type Fire Extinguisher, Clean Agent (HCFC or Halotron I Type), 7.1 kg. (15.5 lbs), wall-hung type and UL/FM approved;
- m) Supply of three (3) units of 10 m long fuel oil sounding tape;
- n) Tagging and marking for all supplied equipment including tank, valves and piping in accordance with the requirements of the relevant technical specifications;
- o) Corrosion protection and painting;
- p) Demobilization including clearing of site/demolition of Contractor's camp facilities; and
- q) All other works and services required to complete the project.

**GW-3.0 MATERIALS AND EQUIPMENT****GW-3.1 General**

All materials to be supplied under this contract shall be new and unused, free from defects and imperfections and best suited for the purpose intended. All materials shall comply with the latest revisions or editions of the specified standards for each equipment specification unless otherwise specified or permitted by NPC.

The names of manufacturers of equipment and articles contemplated for incorporation in the work together with performance capacities and other significant information pertaining to the equipment shall be furnished for approval. Equipment or articles installed or used without such approval shall be at the risk of subsequent rejections.

The equipment and materials to be furnished under this specification shall be essentially the current standard products of the respective manufacturer regularly engaged in the production of such equipment and materials. It shall be designed and manufactured for maximum safety and reliability in accordance with quality specifications.

Original brochures, catalogs and other related technical data sheets of materials and equipment to be supplied by the Contractor under this contract, in binder with cover, shall be submitted during the project implementation for NPC's review and approval prior to fabrication and/or procurement.

Certified mill test reports as required in the relevant sections of this specification and the governing codes and standards shall be furnished by the Contractor for NPC's record. Copies of each mill test report shall be submitted to NPC prior to fabrication of materials covered.

**GW-3.2 Codes and Standards**

All materials, equipment, fabrication, construction, installation, inspection and testing furnished shall conform to the latest specifications and provisions of the following engineering societies or other internationally accepted standards. Other standards which ensure equal or higher quality than the standards mentioned below will be accepted provided they meet the requirements of existing laws and regulations of the Government of the Republic of the Philippines.

ACI	-	American Concrete Institute
AISC	-	American Institute of Steel Construction
ANSI	-	American National Standard Institute
API	-	American Petroleum Institute
ASME	-	American Society of Mechanical Engineers
ASNT	-	American Society for Non-Destructive Testing
ASTM	-	American Society for Testing and Materials
AWS	-	American Welding Society
NFPA	-	National Fire Protection Association
OSHA	-	Occupational Safety and Health Administration Act of 1970
SSPC	-	Steel Structures Painting Council

In the event of any conflict among the above listed codes or this Specification, Appendices and Attachments, Contractor shall refer the conflict to NPC for written resolution. The responsibility shall be on the Contractor to show the suitability of any alternative standards he may wish to use without NPC approval.

In addition to the above codes and standards, Contractor shall comply with all applicable State and local laws and regulations. The latest edition of each standard shall mean the latest edition available at the date of contract signing.

Other internationally recognized national standards may be accepted, if in the opinion of NPC, such will guarantee a quality not inferior to that guaranteed by the above standards. The list of these alternative standards which the Contractor proposes to adopt must be attached to his Bid for acceptance. In every case, Contractors must list fully the standards they will conform to for this Contract.

All units, dimensions and calculations shall be in metric system.

### **GW-3.3 Test of Materials**

All materials, parts and assemblies to be used shall be tested conforming to the latest specifications and provisions of approved Standards of Testing Materials. Results of the test shall be made to provide means of determining compliance with the applicable specifications. When requested, all test or trials shall be made in the presence of NPC or his duly authorized representative.

### **GW-3.4 Tropical Serviceability**

#### **GW-3.4.1 General**

In choosing materials and their finishes, due regard shall be given to the humid tropical conditions under which the equipment is to work. Some relaxation of the following provisions may be permitted where equipment is hermetically sealed but it is preferred that tropical grade materials should be used wherever possible.

#### **GW-3.4.2 Metals**

Iron and steel are in general to be galvanized or painted, as appropriate or specified. Small iron and steel plate (other than SUS 316 stainless steel) of all instruments and devices, the metal parts or mechanisms are to be treated in an approved manner to prevent corrosion. Other components which are laminated, or which cannot be rustproofed, shall have all the expected parts thoroughly cleaned and heavily enameled, lacquered or compounded.

**GW-3.5 Workmanship**

Workmanship shall be of first class quality and in accordance with the best modern engineering practice for the manufacture, assembly, installation and test of equipment, notwithstanding any omissions from the specifications and drawings. To have quality workmanship, only technicians skilled in their respective trades shall be employed.

**GW-4.0 DESIGN AND DUTY CONDITIONS****GW-4.1 Acknowledgement to Site Conditions**

The Contractor shall be responsible for visiting the site to determine the nature, location and extent of work, the physical conditions, and the availability of materials and facilities needed to undertake the work. The Contractor shall thoroughly investigate and familiarize himself with all the conditions at the site, assessment of existing facilities/installations affected by the works under this contract, the surrounding area, means of communication and transportation, and all other factors that could hamper the smooth execution of the contract.

Any and/or all expenses arising through the lack of knowledge or understanding regarding the existing conditions of the sites shall be the responsibility of the Contractor and no additional payment thereof shall be made by NPC.

**GW-4.2 Site Conditions**

The conditions stated below may be applied unless otherwise specifically indicated in the relevant section of this specification.

Elevation above sea level	:	0 to 500 m
Ambient temperature	:	25 - 40°C
Barometric pressure	:	760 mm Hg
% Relative humidity	:	up to 100%
Design for seismic loads	:	Seismic zone factor 0.4
Max. wind velocity	:	250 km/hr and/or as specified in the latest edition of National Structural Code of the Philippines.

The prevailing atmospheric condition at site is generally warm and humid.

**GW-4.3 Earthquake and Wind Design Requirements**

The equipment and its associated structure may be subjected to both horizontal and vertical seismically induced acceleration of 0.40 g. or more depending on:

- a) Natural period and mode of vibration;
- b) Damping (inherent or specifically provided);
- c) Manner of failure (ductile or brittle); and
- d) Location (at ground level or at a higher level).

The equipment and its related structure required under this contract shall meet the seismic design requirement for earthquake conditions to conform with the latest edition of National Structural Code of the Philippines.

It is evident from the design response spectra that the degree of response varies markedly with the period of vibration. It is essential, therefore, that all equipment, or its supporting structure which has modes of vibration or components with modes of vibration with a natural period longer than 0.1 seconds be identified.

Provision shall be made for seismic movement by providing seismic movement joints between components that are interconnected and may have different vibratory characteristics. These joints shall be capable of withstanding the sum of the maximum deflection of each component resulting from a design earthquake.

The equipment and its related structure under this contract shall meet the requirements for a basic wind speed of not less than 250 km/hr gust and/or as specified in the latest edition of National Structural Code of the Philippines. The wind load shall be based on ANSI Standard A58.1 – 1972.

#### **GW-4.4 Sound Control**

The Contractor shall ensure that the sound levels of equipment and tools to be used during the performance of his works are within the permissible limits for personnel as defined in DOLE's Occupational Safety & Health Standards for Noise and contractual requirements for overall plant noise levels.

If the Contractor expects the maximum sound level of his equipment to exceed 90 dBA at a distance of 1 meter, Contractor shall use acoustical treatment features to achieve the sound control design objectives.

#### **GW-5.0 EQUIPMENT MARKING, LABELING AND MISCELLANEOUS REQUIREMENTS**

##### **GW-5.1 Identification System**

Tag Numbers or Standard Plant Identification Number (SPIN) for all supplied equipment and materials such as tank, pump, valves, strainers, instruments, panels and piping shall be provided by the Contractor. Tag Numbers/SPIN are designated with an alphanumeric code allowing clear identification of the equipment and materials which will be used to achieve uniformity and standardization in identifying each component and equipment for installation, maintenance, documentation and record purposes.

The Tag Numbers/SPIN shall be clearly inscribed in a stainless steel or approved corrosion resistant metal.

Each equipment and auxiliaries shall be systematically marked both on the drawings and documents including cables, wires and terminals, as applicable.

Equipment codes or Tag Numbers/SPIN shall be indicated on all drawings and documents including bills of materials, lists of spare parts, etc. The codes will be used by respective NPC group for easy identification of stored equipment parts and materials and shall be suitable for use with a computer supported registration system.

Tender drawings are in most cases already marked with designated codes (Tag Numbers or SPIN); the system shall be expanded to include detailed diagrams, cable lists, spare parts list, etc., as approved by NPC.

#### **GW-5.2 Nameplates and Labels**

All equipment and auxiliaries to be supplied by the Contractor under this contract shall be provided with 1 mm thick of stainless steel or approved equivalent corrosion-resistant nameplate or label with clearly legible writing of approved size/thickness and pattern which shall be permanently attached to each assembled piece of equipment at an easily visible place subject to approval by NPC.

Nameplates generally contain all necessary information or brief technical description under which the equipment has been designed to operate and shall include the following: manufacturer's name, type of equipment, serial number, year of manufacture, Standard Plant Identification Number (SPIN), weight and other relevant information in compliance with applicable standards. Any special instructions shall also be shown and suitably attached, as much as practicable, to the equipment or other visible location near the subject equipment.

Equipment Nameplates which are manufacturer's standard and may not contain NPC's SPIN may be acceptable provided that Labels bearing the SPIN shall be attached to the equipment and accessories subject to NPC's approval.

Nameplates shall be attached by screws, the use of glue is only permitted for fixing labels on inside of a panel where screws are not applicable due to physical size of equipment.

Nameplate shall be provided and securely fixed to the tank at location which is readily visible. The main inscriptions on the nameplate shall include Tank Tag Number/SPIN, Manufacturer/fabricator, Design Code, Nominal Capacity, Nominal Diameter, Nominal Height, Date of Manufacture and etc.

Labels contain only the Standard Plant Identification Number (SPIN) and/or description of each component or equipment for maintenance management and record purposes. In case SPIN is already factory fixed in the Nameplate, Labels are no longer required.

Labels for valves and instruments shall be secured by screws or by flexible wires.

In addition to labels, a direction of flow for pipelines shall also be identified by arrows painted with color different from the pipe base color. Size of labels varies with the size of the equipment and subject for NPC's approval.

Labels or SPIN for piping and tank shall distinctly be printed on its external surfaces.

If it is not practical to include the SPIN or tag number on the equipment nameplate, a separate durable stainless steel tag with the identification number shall be securely attached to the equipment.

Each equipment wherever necessary, shall be provided with cautionary and warning plates and signs in accordance with the prescribed ANSI/IEEE or equivalent IEC Standards for the equipment.

Nameplates, labels and warning plates shall be in English.

#### **GW-5.3 Erection Marks**

All members comprising multi-part assemblies are to be marked with distinguishing numbers and/or letters corresponding to those of the approved drawings or material lists. These erection marks, if impressed before painting or galvanizing, shall be clearly readable.

Color banding of a code approved by NPC is to be employed to identify members of similar shape or type but of differing strengths or grades.

#### **GW-5.4 Guards**

Guards shall be provided for coupling, drive shafts, fans, etc. These shall comply with ANSI Standard B15.1, Safety Code for Mechanical Power Transmission Apparatus.

#### **GW-5.5 Lifting Lugs**

Lifting lugs or points where lifting lugs supplied can be attached to each item of equipment or component which requires to be removed for servicing and which weighs more than 20 kg shall be adequately provided.

### **GW-6.0 DRAWINGS**

#### **GW-6.1 Drawings Contained in the Tender Document**

The drawings called for in this section shall be the Bid Drawings attached to the Tender Document.

Discrepancies between the drawings and actual field conditions or between drawings and specifications shall immediately be brought to the

attention of NPC for proper resolution. All works involving discrepancies shall not be started without NPC's formal approval.

Anything mentioned in these specifications and not shown on the drawings, or shown in the drawings but not mentioned in the specifications but which are obviously necessary to make a complete installation shall be considered and included as if they are both mentioned and shown.

The drawings and the specifications are complimentary to each other and what is called for in one shall be as binding as if called for both.

Bid drawings may be used for planning the work but shall not be used for construction purposes or for furnishing materials, unless authorized or approved by NPC. Bid Drawings which show the work to be done as definitely and in as much detail as possible may be used as guide by the Contractor to proceed in the performance of his work.

Drawings which require changes or adjustments to suit with actual site conditions shall be prepared/submitted by the Contractor for NPC's review and approval.

## **GW-6.2 Contractor/Manufacturer Drawings**

### **GW-6.2.1 General**

Prior to procurement of all materials, equipment and auxiliaries to be supplied by the Contractor under this contract, the Contractor shall submit for NPC's review, approval, and/or reference, five (5) copies of prints of drawings (outline/arrangement drawings of equipment and its auxiliaries, wiring diagrams), and/or brochures. NPC shall review, comment or note corrections to be made and return two (2) copies to the Contractor within twenty (20) calendar days after receipt of the drawing. If corrections are required, the Contractor shall make all necessary corrections and re-submit such within fourteen (14) calendar days for NPC's review and approval.

Drawings approved by NPC shall in no way relieve the Contractor from entire responsibility for engineering, design, workmanship, material and all other liabilities under the Contract.

NPC reserves the right to reproduce any drawings or prints received from the Contractor as may be required despite any notice prohibiting the same appearing on the drawing or the print. All drawings are preferred in a computer-aided format. However, if unable to comply with this requirement, manual drafted drawings will be acceptable. All CAD produced drawings are to be submitted in AutoCAD formats. All other computer-generated documents are to conform to Microsoft Office.

The Contractor shall submit construction and detailed drawings as may deemed necessary, as-built drawings and other documents for NPC's review, approval, information and reference as specified in this section and relevant specifications.



Before submitting any detailed drawing for review, the Contractor shall obtain approval of a list of detail drawings he proposes to submit. Only selected drawings in the list, or any drawings as NPC deemed necessary, shall be submitted for approval. The sequence of submission shall be such that information is available for checking each drawing when it is received.

Any construction of any structure or portion thereof prior to the approval of drawings pertinent thereto shall be at the Contractor's risk. The Contractor shall be responsible for any extra cost that may arise in correcting the work already done to conform with the drawings as revised and approved.

Should an error be found in the Contractor's drawings during construction/erection, the correction including any field change considered necessary shall be noted on the drawings and shall be resubmitted for approval.

All data and information to be submitted shall be in the English language and all drawings shall be drawn using the metric system as unit of measurement.

All approved drawings shall form part of the Contract. Approval of the Contractor's drawings shall not be construed to mean relieving the Contractor of any of his responsibility for the correctness of his calculations and drawings nor for the strict compliance with the Contract.

All drawings submitted by the Contractor or by any Sub-Contractor shall contain in the lower right-hand corner, in addition to the Contractor's name, the date, drawing scale, drawing title and number, and contract number as given in the Specification. NPC Standard Specifications for Title Blocks shall be provided to the Contractor during the contract implementation.

#### **GW-6.2.2 As-Built Drawings**

The Contractor shall provide and keep up to date "As-Built" drawings of all structures constructed. These drawings shall show all changes or revisions from the original drawings and locations, embedded piping, and other concealed items of Works.

The Contractor shall furnish prints of these drawings. They shall be kept in the Contractor's field office and shall be used only as a record set. At the end of every month, all entries, changes, or revisions made in the drawings by the Contractor shall be checked and approved by NPC.

The complete and duly checked and approved "As-Built" drawings shall be submitted by the Contractor within thirty (30) calendar days from the completion of the contract or prior to the issuance of the certificate of completion, on four (4) prints and one (1) set of write-once recordable CD's. Such CD's shall be suitable for any optical drive of computer system.

Drawings and schedules shall be preferably submitted in standard A3 size.

No separate payment will be made for furnished "As Built" drawings. Contractor shall include at cost thereof in the unit and lump sum bid prices in the Bidding Form.

#### **GW-6.2.3 Processing of Drawings**

The Contractor shall address all communications pertaining to Contractor's Drawings or otherwise agreed to:

The Manager, Design and Development Department  
National Power Corporation  
BIR Road corner Quezon Avenue,  
Diliman, Quezon City 1100

All drawings and documents to be submitted by the Contractor for NPC's review and approval shall be on A4 size or A3 size folded to A4.

NPC shall review, comment or note corrections to be made and return two (2) copies to the Contractor within twenty (20) calendar days after receipt of the drawing. If corrections are required, the Contractor shall make all necessary corrections and re-submit within fourteen (14) calendar days for NPC's review and approval.

Five (5) prints with dark lines on a white background shall be furnished to NPC for each drawing submitted for approval. Two (2) copies will be returned to the Contractor either marked "Approved", "Approved with Corrections Indicated", or "Returned for Corrections". When prints of drawings are marked "Approved with Corrections Indicated" or "Returned for Corrections", the Contractor shall finalize the drawings and re-submit same in five (5) copies each for final approval. Every revision shall be shown by number, date and subject in a revision block.

Prints marked "Approved" or "Approved with Corrections Indicated" authorize the Contractor to proceed with construction or fabrication of the work shown on the drawings, with corrections, if any, indicated thereon.

If minor revisions are made after a drawing has been approved, the Contractor shall furnish two (2) additional prints, subsequent to each revision. No major revision affecting the design shall be made after a drawing has been marked "Approved" without re-submitting the drawing for formal approval of said revision.

Failure of the Supplier to submit the approved "As-Built" or "Final" Drawings to NPC on the respective dates specified in this section, NPC shall withhold Five percent (5%) of contract amount from payments due to the Supplier.

**GW-6.3 Documents for NPC's Records**

The Contractor shall furnish five (5) copies of the following documents for NPC's records:

- a) Material Data, Material Certifications and Test Reports required by governing Codes and Standards; and
- b) Factory Test/Site Test (Performance) Results

**GW-7.0 INSPECTION AND TESTS****GW-7.1 General**

The Contractor shall perform at his own expense all tests required to ensure adequacy of material, workmanship and conformance of equipment to the requirements of the specifications and standards.

The Contractor shall submit to NPC for approval, a complete test program for all his supplied materials/equipment and workmanship covered by the contract. Likewise, five (5) copies of test procedures shall be submitted for approval at least forty five (45) days prior to the conduct of actual test.

NPC and/or his duly authorized representatives shall witness all applicable tests detailed in the relevant sections. NPC shall be notified by the Contractor thirty (30) days in advance about any tests to be conducted requiring the presence of NPC.

Tests not requiring the presence of NPC shall be, in any case, notified in advance. In such case, the Contractor shall then proceed with the tests and shall submit test reports in five (5) copies to NPC. NPC's acceptance of the work by waiving the inspection of tests and receipt of the Contractor's Certified Test Reports and Inspection and Testing Certificate shall in no way relieve the Contractor of his responsibility in accordance with the requirement of the Specifications.

For inspected or tested goods that fail to conform with the Specification, the Contractor shall either replace or make any alterations necessary to meet the requirements of the Specifications at no costs to NPC.

The Contractor shall provide the required consumables, if any, to be used during the test, unless otherwise specified in the relevant sections of the technical specifications.

During the test and upon written request of the Contractor, NPC may provide personnel to assist the Contractor in the performance of the test under the direction of the Contractor.

NPC or its designated representative shall be entitled to attend the tests and/or inspections conducted on the premises of the Contractor or its Contractor(s) provided that NPC shall bear all of its own costs and expenses incurred in connection with such attendance including, but not limited to, all traveling and board and lodging expenses. The Contractor, however, shall extend all reasonable facilities and assistance during the conduct of such test and/or inspection on its premises.

**GW-7.2 Inspection/Tests at Contractor's Premises**

NPC reserves the right to inspect all shop and assembly work associated with the Works, verify quantities consigned to stores and inspect quality control and assurance records as well as shop and purchase order records. When scheduled, and as often as NPC deems appropriate, progress will be monitored with respect to Key Dates in the Contract Schedule and the sequence of events and activities on the Contractor's Detailed Contract Schedule.

The Contractor shall carry out all tests in accordance with the requirements of the specifications and submitted test procedures duly approved by NPC.

Prior to shipment and final inspection, each equipment supplied by the Contractor shall be given the manufacturer's standard factory acceptance test and/or as required in the relevant sections of the technical specifications.

The Contractor shall carry out tests, as may be required by the specified Standards and the Quality Control and Assurance Program, as well as the entire test program approved by NPC.

If NPC opted not to witness the Factory Tests, NPC will issue a Certificate of Waiver of Tests Witnessing/Inspection for the equipment and materials. In such case, the Contractor shall proceed with the Factory Tests in accordance with the requirement of the specification and the manufacturer's test specification as approved by NPC.

Issuance of the Certificate of Waiver of Tests Witnessing/Inspection for equipment required to be witnessed by NPC or its authorized representative(s) however, shall in no way relieve the Contractor of his responsibility to conform with the approved test procedures and the requirements of the Specifications.

The factory test record and dispositions, and any other pertinent supporting data and documents shall form part of a test report to be submitted in accordance with the specification.

**GW-7.3 Site Test**

After installation of all Contractor's supplied equipment and materials, the Contractor shall provide the services of highly qualified personnel who shall be responsible in providing technical advice and overall supervision for the performance of site tests. He shall also closely coordinate with NPC personnel who will be witnessing the site tests.

All tests shall be carried-out in accordance with the approved procedures submitted by the Contractor for his supplied equipment or as directed/coordinated with NPC.

The Contractor shall be responsible in compiling, recording and submitting the test reports to NPC.

Measuring and testing instruments, tools, equipment and devices shall be supplied by the Contractor.

#### **GW-7.4 Tests Failures**

If any equipment or materials supplied by the Contractor fails to pass any test, NPC may direct the Contractor to make any necessary corrections or alterations for defects or order equipment/component replacement, as maybe deemed appropriate. All expenses due to additional tests or retests made necessary by failure of Contractor's supplied equipment/component, i.e., failure to meet the acceptance criteria and other requirements of the specification, shall be borne by the Contractor.

#### **GW-7.5 Test Reports/Certificates**

Five (5) certified copies of the reports of all tests and other manufacturer standard tests shall be furnished to NPC within a maximum of fifteen (15) days following the completion of the tests.

Test certificates shall include, in addition to the test results, the following information:

- a) Equipment data; and
- b) NPC's tag number; and/or equipment serial number.

The Contractor shall bear the cost of furnishing these records and reports.

### **GW-8.0 QUALITY ASSURANCE REQUIREMENTS**

#### **GW-8.1 General**

The Contractor shall have a well-organized Quality Management System which is relevant for the Works covered under the contract to assure that items and services, including subcontracted items and services, will comply with this specification.

Within thirty (30) days of the Effective Date of Contract, the Contractor shall submit five (5) copies of his complete quality control and assurance procedures, and manuals for review and approval by NPC. The manual shall include pro-forma checklists for all requirements of the Contractor's quality control and assurance program and those called for in this Specification.

#### **GW-8.2 Quality Assurance Program**

The Contractor shall, for all work covered by the Contract:

- a) Establish procedures for adequate planning and resourcing of all quality related activities including the preparation of quality plans;
- b) Establish measures for the identification and control of items throughout all stages of the Contract. This shall include measures to maintain traceability as identified in agreed quality plans;

- c) Arrange for the protection of the quality of the product and/or services to include delivery to the specified destination and/or performance of the required services, respectively; and
- d) Control their measuring and test equipment in accordance with the established procedures for measurements and calibration systems and ensure that such equipment that may be used by subcontractors to verify work is similarly controlled.

Where any site installation and/or test and commissioning work is involved, the Contractor shall prepare contract-specific quality assurance procedures in agreement with NPC prior to commencement of such works.

The Contractor shall ensure that all computer systems and software to be utilized on the project is qualified for the application under consideration and such qualification is documented.

#### **GW-8.3 Quality Plan**

The Contractor shall establish and implement quality plans detailing the specific activities, design reviews, operations, control procedures, inspections, testing, approvals, and certification requirements as applicable. All procedures, which support the quality plan shall be referenced and distributed to NPC together with the quality plan. Quality plans shall be submitted to NPC for review and approval.

#### **GW-8.4 Records**

The Contractor shall generate records as required by the quality assurance system and quality plans. The Contractor shall make available its records including audit reports for NPC's inspection.

All records shall be concisely compiled, indexed, and cross-referenced to the project contract number and the relevant subcontract numbers. They shall be clearly identifiable to the individual parts and assemblies to which they refer.

All records generated during the course of the Contract, including those generated as evidence of effective implementation of the quality assurance program of the Contractor and his subcontractors, shall be retained by the Contractor for a minimum period of five (5) years from the date of contract completion. These records shall be made available to NPC on request during the retention period.

#### **GW-8.5 Reporting and Corrective Action**

The Contractor's quality assurance program shall provide established procedures for prompt detection and correction of all conditions adversely affecting quality, including failures, malfunctions, incidents, trends, deficiencies, deviations, non-conformances, and defective materials.

**GW-9.0 DEMOLITION AND RELOCATION OF EXISTING EQUIPMENT AND STRUCTURES****GW-9.1 General**

The Contractor shall make full provision in his bid for the relocation, dismantling, assembly or demolition of existing equipment and associated structures and installations wherever this is required or prerequisite to the performance of the works. He shall furnish all necessary plant, equipment, tools and labor and execute the dismantling, assembly, relocation and demolition including disposal of debris and transportation, storage, reassembly and re-erection of dismantled equipment in accordance with the drawings or as directed by NPC.

**GW-9.2 Dismantling of Existing Installations**

Materials and equipment which are required to be reinstalled at new locations shall be handled with care at all times to prevent damage of any kind during dismantling and any such damage shall be made good by the contractor to the satisfaction of NPC.

Dismantling operations shall be executed in an orderly sequence, by suitably skilled personnel, in such a manner as to minimize the number and size of the resulting components.

**GW-9.3 Storage, Transportation and Re-Erection**

All dismantled materials and equipment shall be transported to the location where they are to be re-erected. If not immediately required at the location, they shall be carefully stored and maintained at such place and in such a manner as NPC may direct until such time as they are required at their new location.

Dismantled materials and equipment shall always be handled with care to prevent damage during transportation, storage and re-installation and any such damage shall be made good by the Contractor to the satisfaction to NPC.

The Contractor shall provide temporary shelter/cover such as tarpauline or equivalent type of cover for protection of the equipment which requires protection from rain, dust or direct sunlight during the storage.

Re-erection and re-installation of all dismantled materials and equipment shall be carried out by skilled and qualified personnel with special training and experience in the appropriate trade.

**GW-9.4 Demolition**

The Contractor shall exercise due care and diligence during demolition structures, equipment, and installations, including the provision of screens and canopies to protect them from dust and debris. If any such damage should occur, the Contractor shall repair, replace or otherwise make good all damaged items to the approval of NPC.

All demolition operations shall be carried out in an orderly manner so as to cause minimum interference with other construction activities or the operation of the existing equipment and utilization of associated structures.

#### **GW-9.5 Disposal of Demolished Materials**

All debris and demolished materials shall be transported to a location designated by NPC and dumped or otherwise disposed of as directed by NPC.

If any demolished materials which are not required to be used elsewhere have a commercial value, he may direct the Contractor to set aside and salvage such materials, the proceeds of which shall be credited to NPC.

All salvable materials shall be carefully handled to avoid damage and shall be piled neatly at a location adjacent to the work or as directed by NPC. All salvable materials shall become the property of NPC and the Contractor shall be held responsible for all materials not accounted for. The salvable material shall not be used by the Contractor for any of his construction operations, unless otherwise authorized by NPC.

The Contractor shall clean the area of debris and hazardous materials resulting from the removal/dismantling of the equipment from the sites mentioned herein. The areas should be free from safety and environmental hazards during and after the dismantling activities.

#### **GW-10.0 CORROSION PROTECTION AND PAINTING**

##### **GW-10.1 General**

The Contractor shall be responsible for the adoption of preparation procedures and protective coating systems that are suitable for the environment experienced by the various components/elements of the Plant.

Where a specific coating system is mentioned elsewhere in the specification, the Contractor shall accept responsibility for the suitability for such system. The Contractor has the option to nominate an alternative coating system that is of equal or better-quality subject for the approval of NPC.

At least forty five (45) calendar days from the expected or planned completion of major construction and installation/erection activities of the Contract, the Contractor shall submit for the approval of NPC, a full schedule of coating systems including the following information:

- a) Plant item name;
- b) Protective coating systems including number and thickness of coats;
- c) Short list of protective coating manufacturers and applicators;



- d) Surface preparation;
- e) Workshop action; and
- f) Final color schedule as specified in the relevant sections of this specification or as directed by NPC.

#### **GW-10.2 Treatment for Shipping**

The various items of materials, which do not fall under the paintings or lining specifications in the documents, shall be surface treated for shipping.

The various items of materials and equipment which constitute the supply shall be thoroughly cleaned before shipment as to eliminate dirt, rust and grease and all welding slugs, spatters and loose metals.

All metallic machined surfaces shall be covered with a protective coating. This coating shall be effective against salty air and shall be easily removable at site.

All iron or steel external surfaces shall be covered with two (2) coats of protective anti-rust paint.

All internal surfaces of tank shall be coated with an easily washable corrosion preventive compound.

Piping, valves and other parts that have undergone hydraulic tests and which cannot be completely dried should be treated with water-absorbing corrosion inhibitor before the application of protective coating.

#### **GW-10.3 Application of Paint**

Before any painting is made, all surfaces must be prepared properly by removing all rusts, scales, welding slugs and spatters, grease and encrustation of any nature. Steel surfaces shall be white metal blast cleaned in accordance with Steel Structures Painting Council Standard. The various paints to be used shall be of high quality and type subject to approval of NPC.

No painting shall take place outdoor during the presence of rain, fog, dew or where the surfaces may be otherwise damp and no application of paint should be made on plaster surfaces that are not completely dry. No coating shall be applied unless the surface is at minimum of 3°C above dew point.

For successive coats, first coat shall be dried hard before the second coat. The color of successive coats must be sufficiently different to allow easy identification of the sequence of painting of surfaces for control purposes.

Paint shall not be applied to machined surfaces, corrosion resistant materials or linings, unless specified in relevant section of this specification.

All contact surfaces of field-welded connections shall be masked at a distance of 100 mm back from the weld joint and shall be suitably protected against corrosion.

For non-insulated surfaces exposed to high temperature, two (2) coats of Aluminum modified silicone with volume solids of  $42\% \pm 2\%$  high temperature paint shall be applied. For insulated surfaces exposed to high temperature one (1) primer coat of Aluminum modified silicone shall be applied prior to installation of insulation.

For internal surfaces for the receipt of oil, three (3) coats of paint having a phenolic-base or equivalent shall be applied. As minimum, first coat shall be applied with 80 microns DFT of zinc rich polyamide epoxy primer. Second and final coat shall be applied with 100 microns DFT polyamide epoxy top coat for each coat. External surfaces shall be painted with 80 microns DFT of zinc rich polyamide epoxy primer on first coat. On second coat, 160 microns FTF of intermediate chlorinated rubber shall be applied and 80 microns DFT chlorinated rubber topcoat as Final Coat.

All other equipment and piping installed outdoors and indoors shall be prime coated with 80 microns DFT zinc rich epoxy paint and 80 microns DFT of chlorinated rubber for each intermediate and topcoat.

All steel pipes laid underground shall be applied with two (2) coats of Coal Tar epoxy polyamide of 170 microns DFT each coat. Unless otherwise specified, asphalt jute or any approved equivalent shall be used for pipes laid underground.

Steel pipes installed underground may also be applied with tape wrapping with minimum finished thickness of 1 mm and shall be applied spirally with overlap of 50% in all parts of the pipe and fittings. Bitumen based primer shall be applied to pipe before applying the tape. The tape wrapping brochures shall be submitted for NPC approval prior to procurement and application. The wrapping shall extend for 300 mm beyond the buried portion.

Exposed fabrication, erection, or shipping marks shall be cleaned off and the areas touched-up shall be painted to match the adjacent surfaces.

For surfaces where blast cleaning and a wash primer are specified, touch-up painting shall include application of the wash primer before the touch-up coats.

Final tests and inspection shall be carried out by Contractor to ascertain the correspondence of the paintwork to the prescribed color and treatment. These tests will indicate whether or not the paintwork is correctly applied and is free from wrinkles or roughness that might affect the adhesion of the protective coating.

Should the measured dry film thickness result to less than the specified one, the Contractor shall apply additional paint to the coat inspected or shall increase the thickness of succeeding coat, as applicable, to assure the specified total dry film thickness.

**GW-10.4 Hot Dip Galvanizing**

The zinc protective coat shall be adherent, smooth and free from discontinuity and imperfections such as bubble, porosity, cracks, or other irregularities of the protective layer.

The thickness of applied layer shall correspond to a minimum rate of 550 gm/m<sup>2</sup>.

**GW-11.0 PACKING, SHIPMENT AND STORAGE****GW-11.1 Preparation**

The Contractor shall prepare materials and equipment for shipment to protect it from damage during shipment and subsequent storage.

Equipment shall be completely drained of all water and thoroughly dry prior to shipment. When such draining requires removal of plugs, drain valves, etc., the Contractor shall make sure that these parts are re-inserted or reassembled prior to shipment. Other fluids, as applicable, (coolant, fuel oil, lube oil, etc.) shall be drained only if the Contractor deems it necessary and subject to the approval of NPC.

All openings and machined surfaces shall be provided with protection to prevent damage, corrosion and entrance of foreign matter during shipment and storage.

Flanged connections shall be protected by a ½ inch (15 mm) or thicker plywood disc, or suitable alternate, bolted to the face of the flange.

Threaded or socket weld connections shall be protected with screwed or snap on type and securely held plastic protectors. Cast-iron plugs are not acceptable for protection unless part of the permanent assembly.

Butt weld connections shall be protected by wooden disks that cover the entire weld end area and shall be secured by metal straps and fasteners.

Covers, straps or fasteners shall not be welded to equipment.

Equipment shall be adequately supported for shipment. All loose parts shall be crated or boxed for shipment and appropriately identified. Where shipment is braced internally, it shall be marked conspicuously, "Remove internal braces before testing and operating".

All large and heavy shipping units shall have suitable skids for moving. Crating shall also be adequate for lifting with slings. If location of slings is critical, these locations shall be marked accordingly.

As the shipment may be left in open temporary storage at the designated place, the Contractor shall ensure that the delivered items have appropriate protection from water and other elements.

All electrical and delicate mechanical parts susceptible to damage from moisture shall be packed in hermetically sealed container or other approved containers within their packing cases, with all machined surfaces coated with a rust preventive compound. All sealed packages shall include bags of silica or equally moisture absorbing chemical. When electric space heaters are provided for that purpose, these should be wired to the outside of the equipment so that energization immediately upon receipt is possible without disassembly of crates, etc. This also requires that no combustible material will be left in the inside of the equipment.

All spare parts shall be packed in a sealed container including special and standard tools in their separate sealed toolboxes.

All packages, crate boxes, drums, bags, bundles, or other containers or any loose pieces shall carry the following identification marks on the two (2) sides in black with a stencil-proof ink or paint by means of block letters not less than 30 mm high; i.e.

**NATIONAL POWER CORPORATION**

CONTRACT No.	:	_____
ITEM NO.	:	_____
PORT OF DISCHARGE	:	_____
DESCRIPTION OF CONTENT	:	_____
NET WEIGHT	:	_____ kgs
GROSS WEIGHT	:	_____ kgs
DIMENSION	:	_____ m <sup>3</sup>
CRATE NO.	:	_____

All packages shall be forwarded with a copy of packing list placed inside the package and another copy thereof contained in a waterproof envelope placed outside the package. The packing list shall give all information on the package such as package no., packing appearance, net weight, gross weight, dimension, measurement, and description of the equipment including storage and handling instructions with descriptions for periodic inspection and/or storage maintenance to ascertain that no deterioration will occur during storage.

Prior to shipment/transport, the Contractor shall furnish advance copies of all packing lists and other pertinent documents.

The Contractor shall employ methods that will warrant safe delivery of equipment and materials to its ultimate destination, with careful consideration given to the type of commodity, method of transportation, destination, storage time, and storage facilities at point of destination.

**GW-11.2 Shipment/Transport**

The Contractor shall be responsible for the sea and land transportation of the plant equipment, materials and supplies required under this Specification and shall ensure that they are safely and timely delivered to the specified site. Contractor shall be deemed to have visited the sites and other areas on the route of delivery, including port facilities, inter-island shipping facilities, island transport, access roads, bridges, and to have acquainted themselves with all factors that will affect the cost of shipping and freight to Site.

Any damages to the roads, bridges, railways if any, etc. arising out of neglect of Contractor shall be the responsibility of the Contractor. Likewise, any additional claim attributable to Contractor's lack of knowledge or understanding on existing conditions of the site shall not be given due credence.

Upon arrival of equipment and materials at site, NPC and the Contractor or their authorized representatives shall jointly verify the plant equipment to be stored at site following the steps below:

- a) Inspection and verification of the packing list;
- b) Visual inspection of the condition of the packing & its surfaces; and
- c) Partial opening of the crates and plastic sheet protection of the plant auxiliary equipment and diesel generating sets to verify the content and its physical condition and to check pilferage or damage during shipment and storage.

A record shall be prepared carefully noting all eventual shortage, defects or damages, signed by the Contractor and concurred by NPC. All shortages and damages noted shall be immediately replaced by the Contractor at his own cost and shall ensure the timely delivery of replacement without affecting the agreed overall project implementation schedule. The Contractor shall be responsible for the care and custody of the equipment from storage until erection.

The Contractor shall keep a proper store ledger carefully noting all movements of materials within the project site. NPC has the right of access to the ledger, which shall be kept by the Contractor on site at all times.

The Contractor shall ship/transport the required equipment and materials on clear commercial bill of lading and the cost of all freight, insurance, shipping, handling and road transport charges, as applicable, shall be included in the Bid Price.

**GW-11.3 Storage**

If the supplied equipment and materials will not be immediately required for installation at the site, the materials and equipment shall be carefully stored and maintained at such place and in such a manner as NPC may direct until such time as they are ready for installation/erection. The Contractor shall provide temporary shelter/cover such as tarpauline or

equivalent type of cover for protection of the equipment during the storage.

The Contractor shall be responsible for securing all his supplied equipment at a place designated by NPC until the completion of the erection/installation, and test. Any loss and/or damage of said equipment at said storage area shall be the responsibility of the Contractor.

If the Contractor desires to use any storage area outside property at the respective sites, he may do so at his own expense and subject to the approval of NPC.

#### **GW-12.0 CLEAN UP**

When the Works are completed and before the issuance of the Certificate of Completion is made, the Contractor shall remove from the Site, without expense to NPC, all temporary structures, all materials and rubbish of every sort, shall fill and dress all holes and cavities made for his convenience, and shall leave the whole area in good order and condition, all as required and directed by NPC.

Unless otherwise directed by NPC, all excess materials and components which form part of the supplied equipment or materials and identified to be no longer required for the construction and erection/installation, shall remain at site and properly turned over to the NPC

#### **GW-13.0 CERTIFICATE OF COMPLETION AND ACCEPTANCE**

When all the works and services have been satisfactorily completed as required in the Contract, the Contractor may give notice to this effect to NPC. Such notice shall be deemed to be the basis for NPC to issue a Certificate of Completion in respect of the Works within fifteen (15) days of receipt of such notice.

After the lapse of the warranty period, provided that there are no defects found and/or pending repair works (including completion of the required Supplier's Service Personnel Services specified in Clause GW-14.0 as certified by the Plant Manager), NPC shall issue the Certificate of Final Acceptance.

#### **GW-14.0 GUARANTEE**

The Contractor shall guarantee that he will repair, and/or replace, at his own expense, equipment and materials against defect in design, materials and workmanship for a period of twelve (12) months after the issuance of the Certificate of Completion. The Contractor guarantees that when the equipment and/or material are placed in operation and/or use, it will perform in the manner as set forth in the Contract.

**GW-15.0 MEASUREMENT OF PAYMENT**

Measurement for payment for all works shall be based on the bid price of each item as shown in the Bill of Quantities. The cost shall cover all works required and described in the pertinent provisions of the specifications which include painting, equipment/pipe tagging and marking.

Failure of the Supplier to submit the approved "As-Built" or "Final" Drawings to NPC on the respective dates specified in this section, NPC shall withhold Five percent (5%) of contract amount from payments due to the Supplier.

# **SECTION VI**

# **TECHNICAL**

# **SPECIFICATIONS**

## **AW – ARCHITECTURAL WORKS**



**SECTION VI – TECHNICAL SPECIFICATIONS**

**AW – ARCHITECTURAL WORKS**

**TABLE OF CONTENTS**

<u>CLAUSE NO.</u>	<u>TITLE</u>	<u>PAGE NO.</u>
<b>AW-1.0</b>	<b>GENERAL ARCHITECTURAL REQUIREMENTS .....</b>	<b>1</b>
AW-1.1	General .....	1
AW-1.2	Submission of Samples .....	1
AW-1.3	Substitution of Materials .....	1
AW-1.4	Certification of Materials .....	2
AW-1.5	Other works which even if not specifically mentioned in the Section and Bill of Quantities shall be included: .....	2
AW-1.6	Measurement and Payment.....	3
<b>AW-2.0</b>	<b>CONCRETE MASONRY WORKS.....</b>	<b>3</b>
AW-2.1	General .....	3
AW-2.2	Materials.....	3
AW-2.3	Installation .....	4
AW-2.4	Concrete Lintel .....	4
AW-2.5	Testing of CHB.....	5
AW-2.6	Measurement and Payment.....	5
<b>AW-3.0</b>	<b>PRE-CAST CONCRETE LOUVERS .....</b>	<b>5</b>
AW-3.1	General .....	5
AW-3.2	Samples .....	5
AW-3.3	Workmanship .....	5
AW-3.4	Materials.....	6
AW-3.5	Installations .....	6
AW-3.6	Measurement and Payment.....	6
<b>AW-4.0</b>	<b>PLASTERED PLAIN CEMENT FINISH.....</b>	<b>6</b>
AW-4.1	General .....	6
AW-4.2	Materials.....	6
AW-4.3	Application.....	7
AW-4.4	Measurement and Payment.....	7
<b>AW-5.0</b>	<b>PAINING AND VARNISHING .....</b>	<b>8</b>
AW-5.1	General .....	8
AW-5.2	Inspection of Surfaces .....	8
AW-5.3	Materials.....	8
AW-5.4	Colors and Samples .....	9
AW-5.5	Workmanship .....	10
AW-5.6	Protection .....	10
AW-5.7	Paint Application.....	11
AW-5.8	Painting Systems.....	13
AW-5.9	Measurement and Payment.....	15



SECTION VI – TECHNICAL SPECIFICATIONS

<b>AW-6.0</b>	<b>WOOD DOORS.....</b>	<b>15</b>
AW-6.1	General .....	15
AW-6.2	Samples .....	15
AW-6.3	Workmanship .....	15
AW-6.4	Materials.....	15
AW-6.5	Installation.....	16
AW-6.6	Measurement and Payment.....	16
<b>AW-7.0</b>	<b>SOIL TREATMENT.....</b>	<b>16</b>
AW-7.1	General .....	16
AW-7.2	Material .....	17
AW-7.3	Application.....	17
AW-7.4	Measurement and Payment.....	17
<b>AW-8.0</b>	<b>FINISHING HARDWARE .....</b>	<b>17</b>
AW-8.1	General .....	17
AW-8.2	Packaging and Marking .....	18
AW-8.3	Qualified Supervision.....	18
AW-8.4	Material Specification .....	18
AW-8.5	Installation and Hardware.....	19
AW-8.6	Measurement and Payment.....	20



## SECTION VI - TECHNICAL SPECIFICATIONS

### AW-1.0 GENERAL ARCHITECTURAL REQUIREMENTS

#### AW-1.1 General

The work to be done under this section shall include the furnishing of all labor, materials, equipment, tools, storage and stockyards of the pertinent materials and structural components and other incidentals for all architectural works enumerated hereunder, as shown on the accompanying drawings or as otherwise directed.

The work shall be performed and completed with high quality workmanship, in accordance with generally accepted modern practice in carpentry fenestrations, tinsmithing, plumbing, painting, landscaping and masonry work, etc. notwithstanding any omission from these Specifications or drawings.

Materials and structural parts that the Contractor shall supply and install, and which will be incorporated in the structure shall be new and unused. They shall be suitable for their intended purpose and appropriately matched to each other complying with all applicable regulations, quality and dimensions standards. Defective work is not acceptable.

#### AW-1.2 Submission of Samples

At least one (1) month before the start of any installation or application of materials, the Contractor shall submit samples of materials for all sections for evaluation and approval. No work shall be done until after samples are approved by the NPC Representative in writing. All work must strictly conform to approved samples as to quality, texture, color and finish.

Failure of the Contractor to comply with the preceding stipulation shall not entitle them of any extension of time nor any claim whatsoever for any delay in the work after rectification due to disapproval of work.

To avoid unnecessary delay, it is suggested that the orders and/or purchase of imported or local materials shall be made within sufficient period in order that adequate supply is available at any time when needed.

#### AW-1.3 Substitution of Materials

The Contractor shall submit a written request for substitution of materials in lieu of those specified when deemed very necessary and urgent. Such request shall indicate the reasons for substitution. No substitute material shall be used without written authorization from the NPC Representative.

In case of approved substitution of an inferior kind of material, a reduction in the contract price equal to the difference in cost of the two kinds of materials shall be made. Market prices at the provincial capital or at a commercial center agreed upon by the NPC Representative and the Contractor on the date upon which authority for substitution is granted shall be the basis of said



price reduction. Price differentials shall be determined and agreed upon immediately by both parties and incorporated in the approved letter of substitution.

The Contractor shall submit written request for substitution at least one (1) month before such materials are actually needed. Such request shall be accompanied by samples to be substituted and corresponding certification.

No price increase will be allowed for a better kind of material.

#### **AW-1.4 Certification of Materials**

The Contractor shall submit to the NPC Representative signed certificates from manufacturer or sole distributor of equipment and materials to be furnished and installed by the Contractor, certifying as to the kind, quality, rated capacity, quantity, performance and other descriptions of the equipment and materials delivered under a receipt number and date. No equipment or materials shall be erected, installed or applied such as electrical fixtures and accessories, concrete reinforcing steel, cement, G.I. and C.I. pipes, valves and fittings, plumbing and sanitary fixtures, building materials and finishes, paint and waterproofing, etc., without the required certificates.

#### **AW-1.5 Other works which even if not specifically mentioned in the Section and Bill of Quantities shall be included:**

- The measurements for the execution and payment of the Works, including provisions of the measuring equipment and the engagement of labor
- Connecting up of water, gas and electricity from the mains of the site indicated by the NPC Representative to the points of use
- Provision of small equipment and tools
- Safeguarding the Works against surface water, which shall normally be reckoned with, and its possible necessary removal
- Protecting the Works from heat, wind and rain
- Protection and safety measures required
- Protecting the executed works and the items handed over the execution of same from damage and theft up to the time of acceptance
- Supplying of the operational materials
- Supplying of consumable stores
- Supplying of fitting dowels
- Supplying of simple type pipe covering, e.g., in the shape of pipe sheathings with corrugated cardboard and the like
- Supplying and fitting of pipe fastening elements, e.g., pipe clips, hangers, etc.
- installing and dismantling as well as providing all framework and scaffolds
- Making blackouts on concrete
- Chemical preservation of timber
- Instructing the operating and maintenance personnel

**NOTE:** The above provisions are general for all types of buildings. The Contractor shall be guided accordingly by the applicable



provisions in the specifications and what is shown in the drawings for each type.

#### **AW-1.6 Measurement and Payment**

Measurement for payment for different items in **Architectural Works** will be based on the areas, lengths, volumes and quantity placed and accepted by the NPC Representative.

Payments for each architectural item will be made at the corresponding contract unit price per square meter, linear meter, cubic meter and number of pieces/sets, for the pertinent items under Architectural Works in the Bill of Quantities.

Payment shall constitute full compensation for all labor, materials, equipment, tools and incidentals necessary for the completion of each work.

#### **AW-2.0 CONCRETE MASONRY WORKS**

##### **AW-2.1 General**

The work to be done under this section shall include the furnishing of all labor, materials, equipment, tools and other incidentals to complete the work.

Concrete masonry units of the type and thickness indicated shall be provided and shall be properly coordinated with the work of other trades. The source of supply for material which will affect the appearance of the finished work shall not be changed after the work has started.

Masonry units shall be handled with care to prevent chipping and breakage. Storage piles shall be so located as to avoid being damaged by construction operations and traffic. Cement and lime shall be stored off the ground under watertight cover until ready for use. Damaged materials shall be rejected.

##### **AW-2.2 Materials**

Concrete Hollow Blocks shall be of standard manufacture, machine-vibrated, fine and even textured and well-defined edges.

Unless otherwise shown on the drawings, concrete hollow blocks to be used shall conform to the requirements of ASTM Specification C-129-39 Minimum Compressive Strength of not less than 4.48MPa average of the fine specimens.

##### **Mortar Proportions:**

Cement mortar for laying concrete hollow blocks shall consist of one (1) part Portland cement, one-fourth (1/4) part lime and three (3) parts sand. Only sufficient water to make a workable mix will be permitted.

- a) Masonry grout for filling cells of concrete blocks shall consist of one (1) Portland cement, one-fourth (1/4) part lime, three (3) parts sand to which three (3) pea gravel is added by volume. Mortar materials shall



be accurately measured by volume and thoroughly mixed until evenly distributed throughout the batch mechanical mix. The actual mixing time shall not be less than two minutes.

- b) Intersecting hollow blocks walls and partitions shall be bonded by overlapping units on alternative course or by the use of 6.3mm (1/4") diameter ties at 610mm (24") O. C. every second course (maximum) anchored in filled cells.

Concrete lintel beams shall extend 305mm (12") beyond both sides of the opening and reinforced with four 12.7mm (1/2") bars placed over and below window openings.

- a) Concrete studs, reinforced with one 12.7mm (1/2") diameter bar, shall be placed at both sides of all window and door openings.
- b) All horizontal reinforcement shall be tied to vertical reinforcement.
- c) Reinforcement shall be as specified in Section "Structural Steel".

Cement shall be Portland cement of approved brand conforming to ASTM Specifications C150, Type I.

- a) Lime shall be made with pulverized and quicklime or with hydrated lime.
- b) Sand shall be clean, washed and free from deleterious substances.
- c) Water for mixing shall be clean and potable.

#### **AW-2.3 Installation**

Laying of all masonry units shall be plumbed, leveled and accurately spaced. All units shall be wetted before laying. The block should be laid on full mortar bedding and in such a way that no cracks are formed between the blocks and the mortar at the time the blocks are placed. All joints should be filled with mortar at the time it is laid. Any horizontal and vertical CHB wall reinforcements shall be anchored to concrete works by means of 10mm (3/8") by 609mm (24") long dowels. Embedding of anchor bolts, expansion shields, conduits, etc. shall be done as the erection progresses.

Cutting and patching of masonry required to accommodate the work of other trades shall be performed by masonry mechanics.

Finishing of all hollow block wall surfaces to be applied with cement plaster will be cleaned and evenly wet slashed with a wash of neat cement and sand followed by 1:2 cement mortar mix 10mm (3/8") thick which shall be applied with a wooden float.

#### **AW-2.4 Concrete Lintel**

Unless otherwise indicated, provide concrete lintels over all openings in concrete unit masonry walls. Lintels shall be cast-in-place and reinforced with



longitudinal bars at the bottom, and of sizes as indicated on the plans. Concrete works shall conform to Concrete Works of these Specifications.

#### **AW-2.5 Testing of CHB**

Test samples from every 500 units shall be taken at random from the CHB to be used before installation. The testing shall be performed by a laboratory approved by the NPC Representative and the cost thereof shall be charged to the account of the Contractor. Concrete hollow blocks represented by such samples, failing to meet the requirements under the latest edition ASTM 6129-70 shall be rejected.

#### **AW-2.6 Measurement and Payment**

Measurement and payment for **Concrete Hollow Blocks** including its reinforcing bars will be based on the area in place and accepted by the NPC Representative.

Payment will be made at the corresponding contract unit price per square meter for the pertinent items under Architectural Works in the Bill of Quantities.

Payment shall constitute full compensation for all labor, materials, equipment, tools and incidentals necessary for the completion of this work.

#### **AW-2.0 PRE-CAST CONCRETE LOUVERS**

##### **AW-3.1 General**

The work to be done under this section include the furnishing of materials tools and equipment and performing labor required to complete the pre-cast concrete louvers as shown on the drawings or as specified.

All accessories shall be in accordance with the applicable provisions in section *AW-8.0 Finishing Hardware*.

The Contractor shall furnish and install pre-cast concrete louvers as shown in with the applicable drawings and specification and manufacturer's standards.

##### **AW-3.2 Samples**

Samples of pre-cast concrete louvers shall be submitted by the Contractor to the NPC for approval before fabrication commences.

##### **AW-3.3 Workmanship**

The Contractor shall take special care in the manufacturing and assembly process of joint work. All joint works shall be done in accordance with accepted practices and shall be accurate and clean so as the joined elements fit perfectly together.



**AW-3.4 Materials****1. Pre-cast Concrete Louver**

- a) Warehouse Area and Engine Room – 0.25x0.25m pre-cast concrete louver window.
- b) Pre-cast concrete louvers shall be products of reputable, national known manufacturers approved by the Contracting Office.

**AW-3.5 Installations**

- a) Louvers shall be accurately fitted to its frame and hardware.
- b) Allowance shall be given for painter's finish.
- c) All louvers shall operate freely and with all hardware properly adjusted and functioning.
- d) Louvers shall be installed complete with finishing hardware, etc.
- e) Louvers shall be installed in strict accordance with the accepted manufacturers' standards, set plumb, properly aligned and securely anchored.

**AW-3.6 Measurement and Payment**

Measurement and payment for pre-cast concrete louvers will be based on the area installed and accepted by the NPC. Payment will be made at the corresponding contract unit price per area for the pertinent item under Architectural Works in the Bill of Quantities. Payment shall constitute full compensation for all labor, materials, equipment, tools and incidentals necessary for the completion of this work.

**AW-4.0 PLASTERED PLAIN CEMENT FINISH****AW-4.1 General**

The work to be done under this section includes furnishing of all labor, materials, equipment and other facilities and the satisfactory performance of all work necessary to complete all cement plaster finish. Plaster mixture is applied in layers to masonry and reinforced concrete, surface to interior or exterior walls and ceilings.

**AW-4.2 Materials**

- a) Portland cement conforming to the latest edition of ASTM Standards C-150.

Lime - Slaked quicklime or hydrated lime to make lime putty.





Sand - Natural sand, white or light grey, washed and cleaned, strong and free from injurious amount of dust and flaky particles.

Water - Clean and fresh contains no salt, potable and free from sulfur oil and other impurities that may cause discoloration of the finish.

- b) Accessories for plaster work, includes nails, picture, moulds, casings, window stools, bases, etc.

#### **AW-4.3 Application**

The total thickness of masonry and plaster shall be 15mm (5/8"). For a three-coat plastering, the scratch coat and brown coat shall be at least 6.3mm (1/4") thick and the hard finish 3.2mm (1/8") thick with a minimum thickness of 1.6mm (1/16") at any point. For a two-coat work the base shall be 12.7mm (1/2") thick and the hard finish the same as for a three-coat work.

The lath for plastering shall be leveled, plumb and well secured to the backing material. The leveling elements installed would include grounds and screeds. For walls, a screed shall be installed at the base of the wall with its top about 102mm (4") above finish floor. The screed is run horizontally, leveled and set at the exact thickness of finished plaster. Around all openings and the intersection with the ceiling grounds are installed.

All anchorage for cabinets, furniture, stair, handrails, electrical outlets, etc., should be installed before plastering is started.

All internal corners should be reinforced by lapping wire lath. Mixture for various coats should be checked to see that proportions are correct.

Manufacturer's directions for applying the various types of plaster should be followed scrupulously. The NPC Representative should check whether they conform to end use of the plaster.

#### **AW-4.4 Measurement and Payment**

The measurement for payment for all **Plaster Plain Cement Finish** will be based on the area applied and accepted by the NPC Representative.

Payment will be made at the corresponding contract unit price per square meter for the pertinent item under architectural works in the Bill of Quantities.

Payment shall constitute full compensation for all labor, material including metal lath, equipment, tools and incidentals necessary for the completion of this work.



**AW-5.0 PAINTING AND VARNISHING****AW-5.1 General**

The work to be executed under this section shall include the furnishing of all materials, labor, tools and ladders, scaffolding and other facilities necessary for the satisfactory performance of all work necessary to complete all painting and finishing of all surfaces throughout the interior and exterior of the building, except as otherwise specified.

The Contractors, providing the labor, materials or both for this project are specifically referred to the General Contract plans, to the General Conditions of the specifications, to all the Sections of the Specifications and to the various other sub-contract documents which may affect the completion of any sub-contract work. In the absence of a complete agreement between sub-contractors, supply dealers or others affected by the construction of this project, the General Contractor shall be held responsible for the co-ordination of all the work.

The Contractor shall examine all sections of this specification and perform all paintings called for therein.

All woodwork in ceiling, partitions, handrails, cabinet work, grill work, mouldings and others as specified by the NPC Representative shall be painted/varnished.

**AW-5.2 Inspection of Surfaces**

Before starting the work, the Contractor shall inspect all surfaces to be painted. If the surfaces cannot be put in proper condition to receive paint by customary cleaning methods or sanding or sparkling, the Contractor shall notify the NPC Representative in writing. The NPC Representative will cause these defects to be reminded. The commencing of the work by the Contractor indicates his acceptance of the surfaces to be painted and assumes responsibility for the rectification of any unsatisfactory finishing, resulting from his negligence.

**AW-5.3 Materials**

All paint materials shall meet the requirements of the Philippine National Standard Specifications for Paintings.

Paints shall be brought to the Site in tightly closable, convenient, original containers, if nothing to the contrary is stipulated in the Specifications. The containers shall be marked in a durable manner with the following particulars:

- Maker
- Paint and relevant thinner
- Gross and net weights
- Date of supply by the maker's factory

The openings of the containers shall leave enough room for a stirring appliance.



All containers shall be kept tightly closed until the contents are to be used. Immediately prior to use of the contents and before pouring into smaller containers for working purposes, any skin shall be removed and the contents stirred thoroughly, if necessary, with a stirring appliance.

Paints, thinners and filling cements which are not required for immediate use shall be protected against the action of frost and heat.

Only thinners supplied by the makers of the paint or those described by them as suitable shall be use for adjusting paints to working consistency. The instructions of the maker shall be followed in this respect.

Paint and filling cements shall be used in accordance with the maker's instructions.

The Contractor shall obtain from the manufacturer and shall submit to the NPC Representative a paint manufacturer's guarantee for the quality of each painting material and that each coat of paint is compatible with previous and subsequent coats.

Paints which do not have to be prepared by mixing several constituents just prior to use shall be brought to the Site in such a state of readiness that they need only be adjusted to brushing or spraying consistency to meet the relevant working conditions (e.g., temperature), by adding the particular thinners in accordance with the maker's instructions.

With the exceptions of ready-mixed materials in original containers, all mixing shall be done at the job site. No materials are to be reduced or changed except as specified by the Manufacturer of said materials.

The quality of the paints shall be such that they form no solid sediment and at most a slight skin in unopened original containers within 6 months - calculated from the marker's delivery date. A paint which has formed a solid sediment or more than just a slight skin in the unopened original containers by the time of use or which cannot be processed satisfactorily shall not be used. A sediment shall be regarded as solid if it cannot be dispelled quickly and completely by stirring.

The use of white zinc (lithophones) will not be allowed.

A place will be designated by the NPC Representative for the storage of paint materials and tools. Whenever it may be necessary to change the location of this storage place, the Contractor shall promptly move to the newly designated place. The storage space floor shall be adequately protected from damage and from paint. Paint shall be covered at all times, safeguards taken to prevent fire.

#### **AW-5.4 Colors and Samples**

All colors shall be subjected to the approval of the NPC Representative. Tinting of matching colors shall be done under the supervision of the NPC Representative. In all cases, a sample shall be applied on the job and the



NPC Representative must give his approval before work is commenced. If required, three panels, 200 mm x 250 mm (8" x 10") of each color and finish shall be prepared in advance, with the NPC Representative. "Of color selected" shall be understood as all coats specified herein.

#### **AW-5.5 Workmanship**

All work shall be done by skilled mechanics with high quality workmanship. All paints shall be evenly applied so as to be free from sags, runs, crawls or other defects. All painting materials shall be meet the requirements of stress and shall be in accordance with the relevant standards. All coatings shall be of proper consistency and well brushed out so as to show the minimum of brush marks, except varnish and enamel which shall be uniformly flowed on. All brushes shall be clean and in good condition, with heavy brushes preferred. Light brushes shall not be permitted.

Paint shall be thoroughly stirred so as to keep the pigment evenly in suspension when paint is being applied.

No painting shall be done under conditions that are unsuitable for the production of good results. No oil painting shall be done in damp weather.

Application of succeeding coats shall strictly follow the over-coating times specified by the paint manufacturer. If no specific data are available, all coats shall be thoroughly dry before painting shall be applied. At least twenty-four (24) hours shall be allowed between coats. Exterior painting under damp/wet conditions is not allowed.

Painting coat as specified are intended to cover the surfaces perfectly, if surfaces are not fully covered, further coat shall be applied to attain the desired evenness of the paint application.

All parts of moldings and ornament shall be left clean and true to details.

All finish shall be uniform as to sheen, color and texture, except when glazing is required.

#### **AW-5.6 Protection**

The Contractor shall protect the work of all other trades against damage or injury by his employees, or by his materials, tools or utensils used in connection with this contract. Any damage done by him shall be repaired at his own expense, without additional compensation beyond the contract price.

The Contractor shall note that some damage to paintwork during shipment, storage, and building-in and particularly during grouting of the steel lining is unavoidable and the application of all protective treatment shall be programmed accordingly. Care shall be taken to remove salt crystal liable to become deposited during the sea transport and/or storage at seaport by thorough washing with clean fresh water. Before any coat of paint is applied, the surface shall be prepared as hereunder described, so that it is clean and free from all deleterious matter and completely dry.



The Contractor shall be responsible for the complete shop and field coats. Shop coats shall be checked for good quality and where necessary, before proceeding with the painting or coating operations at Site, the Contractor shall clean and repair, including smooth trowel, all shop coats which are defective or damaged.

Protect all parts of the building from paint drops by using clean drop cloths and remove all paint inadvertently placed or dropped on exposed surfaces without damage to same. Close various spaces while painting and exclude dust until finish is dry.

Plumbing systems shall not be used to wash paint brushes or containers.

Temporary or permanent welding shall not be permitted on areas where the welding will damage paint or other protective coatings, unless the areas of coatings which would be damaged thereby are accessible for repairing and inspection. Materials which have been painted shall be handled with care and protected as necessary to preserve the coating in good conditions.

#### **AW-5.7 Paint Application**

Materials, which are subject to working instructions, shall be treated according to these instructions, unless stipulated differently by the relevant paint manufacturer:

Paint, gloss and coating may be worked manually or by machines, unless a particular execution has been stipulated in the Specifications.

Paint, gloss and coat shall be bond firmly and be of even surface without scars and strips.

The surface shall be smooth, if not otherwise stipulated in the Specifications, such as finely or coarsely granulated.

Any paint, gloss or coating shall be applied without filling to create a uniform surface or, when gloss is being applied, a flowing surface with the required materials according to instruction manuals, of white or light shade, unless otherwise stated in the Specifications.

Top finish shall be high gloss, unless otherwise stated in the Specifications.

If flat levels are to be formed, the prime coated surfaces shall be completely being covered with suitable undercoat filler ribbed and smoothed.

Primer protective coating shall be applied on woodwork according to manufacturer's instruction. If several coats are requested, the preceding coat shall need to be dried before applying the subsequent one. This does not apply for wet-on-wet techniques.

Drying periods prescribed by the manufacturer shall be observed, for open surfaces, as well as for edges or irregular surfaces. All edges at doors, windows, skirting, sockets, etc., shall be of sharp and straight line.



New concrete and masonry surfaces must be thoroughly naturalized either by brush or spray with a solution of 2 kg. of zinc sulfate to each gallon of water.

Surfaces so treated shall be tested to ascertain that alkalinity is removed; otherwise a second treatment with the same solution shall be applied. Within 24 hours after drying, all crystals on the surface must be brushed off applying the prime coat.

Metal works shall be kept clean and free from corrosion following installation. Abraded surfaces shall be retouched prior to finish painting, using the same type of paint as prime coat. Galvanized metals shall be weathered or pickled with the approved metal primer in accordance with printed instruction of the manufacturer.

Where components parts of steel or aluminum alloys meet, joints shall be sealed so that no moisture can penetrate between the contact surfaces.

Rivet and bolt heads, protruding corners, sharp section edges and places of difficult access shall be pre-treated.

The paint shall be applied in coats which are as uniform as possible.

The first priming coat shall be applied by brush. Further coats shall be applied by brush if nothing to the contrary is stipulated in the Specifications. Smaller and specially shaped brushes shall be used for rivet and bolt heads, protruding corners, sharp section edges and places of difficult access.

When applying paints by spray-gun, the object to be sprayed shall not be contaminated by water or oil in the compressed air.

In paint systems involving coats, the various coats of paints shall be distinguishable from each other by their shade.

All coats of paint shall be applied only to clean, dry and non-greasy surfaces. In multi-coat paint systems, the coat last applied shall always be sufficient dry, free from any superficial moisture and from dust and dirt before applying the next text coat; only when using the moist oil type of paints may it be necessary for the previous coat to be hard dry.

The Contractor shall inform the NPC Representative in good time before starting to apply the next coat so that the NPC Representative shall have the opportunity of approving the previous coat.

Painting work shall not be carried out at a temperature below +5 °C and above 50 °C. In addition, painting work shall not be carried out on surface affected by the action of rain, fog and moisture or water of condensation; work started on such surfaces may not be continued until the surfaces to be painted are completely dry.



**AW-5.8 Painting Systems**

All surfaces which are required by the Finish Schedules or specifications to be painted, or otherwise finished, shall be given coats of paints or varnish as specified herein. Individual directions printed on the label of the approved paint and varnish shall be strictly followed. Paint thinner or linseed oil of the same brand as the paint to be thinned shall be used.

All materials, supplies and articles furnished shall be the standard products of superior quality. All constituent materials shall conform to the applicable provisions of the latest edition of ASTM Specifications.

The following list indicates painting materials of special compositions considered suitable for various parts of the works.

**Concrete and Plastered Surface**

Any concrete, cement plaster exposed to high humidity 3 coats of a highly weather-resistant synthetic resin-based paint. The first coat shall contain from 5% to 20% thinner as the surface requires.

All concrete (walls, foundations, etc.) backfilled with soil or submerged.

- 1 coat of coal-tar epoxy.
- 2 coats of a mineral-filled water-resistant coat-tar epoxy.

Concrete, cement plaster, etc. exposed to oil, surface shall be dry, if possible sandblasted, clean and slightly roughened.

- 1 coat with a plastic-modified hydraulic mortar.
- 2 coats of an oil-resistant synthetic resin-based paint.

Concrete exposed to Mechanical and Chemical attack.

- 1 coat of colorless 2- pack epoxy-based paint; this shall contain from 10% to 20% thinner as the surface requires.
- 2 coats of 2-pack epoxy-based paint.

Concrete flooring exposed to mechanical wear and oil.

- 3 coats of chlorinated rubber-based paint. The first coat shall contain 15% thinner.

Internal concrete, plastered walls exposed to abrasion.

- 3 coats of an oil-free, synthetic resin-based, dust-binding paint.

Concrete flooring subject to minor mechanical wall.

- 2 coats of an oil-free, synthetic resin-based, dust-binding paint.

Internal plastered ceilings and walls.



- 2 coats of a polyvinyl-acetate dispersion type, non-chalking paint. First coat shall contain up to 30% thinner of clean, fresh water as the surface requires.

#### Wooden Surfaces

- a) Exterior Parts – N/A
- b) Surface shall be smoothed down with adhesive; if machine sanding is involved, a sanding sealer to bind the fibres shall be applied; the surface shall also be dry and free from dust.
  - 1 coat of fungicide and bactericide ingredients after first coat.
  - 2 coats of synthetic resin-based lacquer with white active pigments.
- c) Interior Parts - Application of varnish on wooden interior walls, partitions, T&G ceiling panelling and closets/cabinets.

All materials, supplies and articles furnished shall be the standard products of a known manufacturer approved by the NPC Representative.

- 1) First Coat. Fill open grained wood with natural wood paste fillers, as is, or mixed with oil-wood stain to obtain desired shade. Apply along the grain within 30 minutes. Let dry overnight and sand lightly.
- 2) Second Coat. Apply any one (1) of the colors of oil-wood stain: oak, walnut, marble, and mahogany. Dry overnight and sand lightly.
- 3) Third Coat. Spray required coats of lacquer sanding sealer. Let dry for 30 minutes and sand to smooth.
- 4) Choice of any of the following topcoats:
  - Clear flat lacquer - for standard flat effect.
  - Clear dead flat lacquer - for complete flat lacquer.
  - Super dead flat lacquer - for complete flat lacquer.
  - Clear gloss lacquer - for standard gloss effect.
  - Water white gloss lacquer - for brilliant crystal-clear effect.
  - Versatile spar varnish - for glossy thick coating also applicable for exterior wood surfaces.

When spraying under high humid conditions, add up to ten per cent (10%) by volume of lacquer thinner retarder to prevent blushing of lacquer products.

#### Steel Surfaces

Details are given General Technical Requirements.





**AW-5.9 Measurement and Payment**

Measurement and payment for **Painting and Varnishing** will be based on the area applied and accepted by the NPC Representative.

Payment will be made at the corresponding contract unit price per square meter for the pertinent items under Architectural Works in the Bill of Quantities.

Payment shall constitute full compensation for all labor, materials, equipment, tools and incidentals necessary for the completion of this work.

**AW-6.0 WOOD DOORS****AW-6.1 General**

The work to be done under this section include the furnishing of materials tools and equipment and performing labor required to complete flush type hollow core doors and other wood doors as shown on the drawings or as specified.

Doors shall be thoroughly seasoned, kiln-dried wood and pressure preservative treated. Wood doors shall be products of reputable, nationally known manufacturers approved by the NPC Representative.

All doors shall be of the type and size indicated in the drawings and as specified herein. The top and bottom edges of all wood doors shall be given a coat of water resistant coating after cutting and fittings, and prior to installation.

**AW-6.2 Samples**

Sample shall be submitted showing the corner sections of wood doors and jambs.

**AW-6.3 Workmanship**

The Contractor shall take special care in the manufacturing and assembly process of joint work. All joint works shall be done in accordance with accepted practices and shall be accurate and clean so as the joined elements fit perfectly together.

**AW-6.4 Materials**

Flush Type - Hollow Core Plywood shall be of first class quality marine plywood and the color shall be approved by the NPC Representative.

Framing shall be kiln-dried treated Tanguile for exterior framing and kiln-dried Tanguile for exposed edge framing.



Panel Type Tanguile, KD shall be used for panel doors, stiles and rails; grain and color suitable for natural finish.

Jambs shall be S4S Yakal, common to all doors.

#### **AW-6.5 Installation**

- a) Each door shall be accurately cut, trimmed and fitted to its frame and hardware.
- b) Allowance shall be given for painter's finish and possible swelling or shrinkage.
- c) Clearance shall not exceed 3.2mm (1/8") at lock and hanging stiles and at top; and, 6.3mm (1/4") at bottom.
- d) All corners shall be rounded to 0.07mm (1/26") radius. Lock and rail edges shall be slightly bevelled.
- e) The screws for hardware shall not be driven, but merely started by driving and then screwed home.
- f) All doors shall operate freely and with all hardware properly adjusted and functioning.
- g) Doors shall be installed complete with finishing hardware, e.g. doorknob with key, hinges, doorstop, etc.

#### **AW-6.6 Measurement and Payment**

Measurement and payment for **Wood Doors** will be based on the number of sets installed and accepted by the NPC Representative. Payment will be made at the corresponding contract unit price per set for the pertinent item under Architectural Works in the Bill of Quantities.

Payment shall constitute full compensation for all labor, materials, equipment, tools and incidentals necessary for the completion of this work.

No measurement of payment for door jambs, payment being included in set.

#### **AW-7.0 SOIL TREATMENT**

##### **AW-7.1 General**

The work to be done under this Section shall include all labor, materials, tools and equipment necessary for soil treatment.

The Contractor shall treat the soil under the building and immediate surroundings to make it impervious and toxic to subterranean termites, often referred to as white ants or "anay" by application of soil poison solutions.



**AW-7.2 Material**

Material to be used shall be a solution commonly used by licensed companies or entities engaged in pest control or pest eradication. Banned solutions must not be applied.

**AW-7.3 Application**

The application of solutions follows the sequence of construction and the following are the order treatment:

- a) Thoroughly saturate every linear meter of excavation for footings and other cement work.
- b) After grading and leveling the soil in the ground and layers of gravel laid preparatory to the pouring of concrete, flood or soak every square floor area.
- c) As soon as the building is constructed, just prior to the landscaping of the lawn and garden, saturate every linear meter perimeter of the building, about three (3) meters wide, with the termite proofing solution.
- d) Treat earth fills thoroughly as they may carry termite colonies. As soon as the fill is packed and leveled, saturate every one square meter area with 4 liters of the termite-proofing solution.

An ordinary watering can (sprinkling can) can be used to saturate or saturate areas with the termite-proofing solution. However, for convenience and thorough and faster application, use a power sprayer with 3 to 5 gallons per minute capacity.

**AW-7.4 Measurement and Payment**

Measurement for payment for Soil Treatment will be based on what is required on the Bill of Quantities

**AW-8.0 FINISHING HARDWARE****AW-8.1 General**

This section includes furnishing and installing all finishing hardware, complete. The schedules in this section are intended to indicate the various hardwares but are not guaranteed as to quantity. The Contractor shall check the schedule and drawings for count and any item similar location elsewhere in the building.

In order to identify and establish each kind of hardware, genuine American, Japanese & European products shall be used.



**AW-8.2 Packaging and Marking**

Each item of finishing hardware shall be individually packed and delivered in the manufacturer's original container. Each package or box shall be clearly marked with the manufacturer's name, catalogue number and other markings required for easy identification of the hardware.

A packaging list should be furnished to clearly identify the quantity and type of hardware in every box numbered in accordance with this list.

All hardware shall have the required screws, bolts and fastening necessary for installation packed in the same package with hardware. All packages shall be legibly and adequately labeled indicating the part of the work for which it is intended.

**AW-8.3 Qualified Supervision**

Materials shall be procured from a source of supply approved by the NPC Representative as competent to correctly evaluate the plans, details, and specifications and be prepared at all times to promptly and satisfactorily service the hardware on the job. This supplier must be an established Contractor for builder's hardware who meets all above requirements and who operates an office in this field.

**AW-8.4 Material Specification**

a) Butt Hinges shall conform to U.S. Federal Specifications unless otherwise specified.

- 1) For doors up to 914mm (3' - 0") wide or less, 90mm x 90mm (3-1/2" x 3-1/2") hinges shall be used.
- 2) For closet doors, use long span hinges.
- 3) Where the jamb trim projects to such an extent that the width of the leaf of butt hinges will not allow the door (in normal opening) to clear such trim, butt hinges with leaves of sufficient width shall be provided.
- 4) Finish and Material
  - i. Hinges used for doors to receive point shall be Bonderized and prime coating for painting.
  - ii. Hinges used for doors to receive natural finish shall be wrought steel highly finished, polished and plated.
  - iii. Use only non-ferrous material butt hinges for doors exposed to the weather.

b) Locksets shall conform to U.S. Federal Specifications.



- c) **Hardware Selection and Door Control.** To obtain satisfaction and maximum services, consideration should be given to all of the following basic factors:
- 1) Proper lock selection. Depends on expected usage (lock, series, function), climatic conditions.
  - 2) Proper installation. The use of right installation tools is recommended.
  - 3) Proper door control. To protect locks and other hardware items, the use of door closers and other control devices is vital under certain conditions.
- d) **Keying and Key.** Locks shall be keyed in sets and sub-sets to provide maximum expansion. All sets shall be grand master keyed, and all entrance locks shall be great-master keyed. Designation shall be by the NPC Representative.

Permanent cylinders with construction inserts are to be assembled with all locksets. Change keys are to be packed in cartons marked "packing list". On completion of the job, the NPC Representative will collect all construction keys, remove the construction inserts from the lock cylinders and distribute the lock change keys as directed. Retain Contractor and construction keys for future key system control.

#### Construction

- a) **Mechanism.** Wrought steel zinc plated and dischromated with coil compression springs.
- b) **Exposed trim and parts.** Wrought brass, bronze, aluminium or stainless.

**Installation.** For hollow wood doors and frame, uniform application regardless of function completely reversible for R.H. or L.H. doors.

**Warranty.** Locksets are engineered to meet or exceed applicable government and industry standards for strength, durability and performance. They are fully guaranteed against defects in materials for workmanship.

- Door Closers
- Push/Pull Handles
- Door Stops
- Door Catches

#### **AW-8.5 Installation and Hardware**

All hardware shall be installed in a neat, crafts manlike manner following the manufacturer's instruction. Fasteners supplied together with the hardware, shall be used to secure the hardware in place. Wood screws set in expansion shields, shall be used for securing hardware to concrete or masonry surfaces.



Through-bolts shall be used where specified or necessary for satisfactory installation. After installation, hardware shall be protected from paint, stains, blemishes and damage until acceptance of the work. All hardware shall be properly adjusted and checked out in the presence of the NPC Representative to see that the hinges, locks, bolts and closers operate properly. Any error in cutting or fitting, or any damage to the adjoining work shall be replaced as directed.

**AW-8.6 Measurement and Payment**

No measurement for payment will be made for **Hardware**, the cost of which shall be included in the contract unit price for the pertinent items where hardware is required under Architectural Works in the Bill of Quantities.



**SECTION VI**

**TECHNICAL  
SPECIFICATIONS**

**CW – CIVIL WORKS**

**SECTION VI – TECHNICAL SPECIFICATIONS**

**CW – CIVIL WORKS**

**TABLE OF CONTENTS**

<u>CLAUSE NO.</u>	<u>TITLE</u>	<u>PAGE NO.</u>
<b>CW-1.0</b>	<b>GENERAL CONSTRUCTION FACILITIES.....</b>	<b>1</b>
CW-1.1	Scope.....	1
CW-1.2	Moving-in.....	1
CW-1.3	Contractor’s Camp Facilities.....	1
CW-1.4	Water Supply.....	1
CW-1.5	Sewerage Disposal and Sanitation .....	2
CW-1.6	Fire Protection .....	2
CW-1.7	Construction Power.....	2
CW-1.8	Camp Security.....	2
CW-1.9	Construction Material Storage .....	2
CW-1.10	Removal of Camp and Construction Facilities .....	3
CW-1.11	Measurement and Payment.....	3
<b>CW-2.0</b>	<b>CARE OF WATER DURING CONSTRUCTION.....</b>	<b>3</b>
CW-2.1	Scope.....	3
CW-2.2	Drainage and Dewatering.....	3
CW-2.3	Measurement and Payment.....	3
<b>CW-3.0</b>	<b>ENVIRONMENTAL REQUIREMENTS FOR CIVIL WORK.....</b>	<b>4</b>
CW-3.1	Scope.....	4
CW-3.2	General Conditions .....	4
CW-3.3	Measurement and Payment.....	5
<b>CW-4.0</b>	<b>SITE GRADING.....</b>	<b>5</b>
CW-4.1	Scope.....	5
CW-4.2	Clearing, Grubbing and Miscellaneous Work.....	6
	CW-4.2.1 Clearing and Grubbing .....	6
	CW-4.2.2 Miscellaneous Works .....	6
CW-4.3	Grading .....	6
	CW-4.3.1 General .....	6
	CW-4.3.2 Classification of Materials.....	6
	CW-4.3.3 Stripping .....	6
	CW-4.3.4 Excavation and Fill.....	6





	CW-4.3.5 Slides .....	7
	CW-4.3.6 Slip-Outs .....	8
CW-4.4	Disposal .....	8
CW-4.5	Sources of Fill Materials .....	8
CW-4.6	Environmental Requirements .....	8
CW-4.7	Measurement and Payment.....	8
	CW-4.7.1 Clearing and Grubbing .....	8
	CW-4.7.2 Miscellaneous Works .....	8
	CW-4.7.3 Stripping .....	9
	CW-4.7.4 Grading Excavation.....	9
	CW-4.7.5 Grading Fill.....	9
<b>CW-5.0</b>	<b>STRUCTURAL EXCAVATION, FILL AND BACKFILL.....</b>	<b>9</b>
CW-5.1	Scope.....	9
CW-5.2	Materials .....	10
	CW-5.2.1 Structural Excavation .....	10
	CW-5.2.2 Structural Fill .....	10
	CW-5.2.3 Special Foundation, if any .....	10
	CW-5.2.4 Structural Backfill .....	11
CW-5.3	Construction .....	11
	CW-5.3.1 Excavation.....	11
	CW-5.3.2 Structural Foundation Fill.....	12
	CW-5.3.3 Special Foundations.....	12
	CW-5.3.4 Backfill.....	13
CW-5.4	Measurement and Payment.....	13
	CW-5.4.1 Structural Excavation .....	13
	CW-5.4.2 Structural Foundation Fill.....	14
	CW-5.4.3 Special Foundations.....	14
	CW-5.4.4 Structural Backfill .....	14
	CW-5.4.5 Trench Excavation and Backfill for Sewerage, Drainage and Water Supply Pipes and Cable Trench .....	14
<b>CW-6.0</b>	<b>CONCRETE .....</b>	<b>14</b>
CW-6.1	Scope.....	14
CW-6.2	Class of Concrete .....	15
CW-6.3	Materials .....	15
	CW-6.3.1 Cement .....	15
	CW-6.3.2 Reinforcing Steel .....	15
	CW-6.3.3 Water .....	15
	CW-6.3.4 Aggregates.....	15
	CW-6.3.5 Formwork .....	15

CW-6.4	Storage of Materials.....	16
	CW-6.4.1 Cement and Aggregates .....	16
	CW-6.4.2 Reinforcing Steel .....	16
CW-6.5	Concreting.....	16
	CW-6.5.1 General.....	16
	CW-6.5.2 Formwork Construction .....	16
	CW-6.5.3 Placing Reinforcement.....	18
	CW-6.5.4 Mixing Concrete.....	18
	CW-6.5.5 Placing Concrete .....	18
	CW-6.5.6 Finishing Concrete.....	18
	CW-6.5.7 Removal of Forms.....	19
	CW-6.5.8 Curing and Protection .....	19
	CW-6.5.9 Sampling and Testing of Concrete.....	19
	CW-6.5.10 Tolerances and Repair for Concrete Construction .....	20
	CW-6.5.11 Second Stage Concrete .....	20
CW-6.6	Measurement and Payment.....	21
<b>CW-7.0</b>	<b>REINFORCING STEEL.....</b>	<b>21</b>
CW-7.1	Description .....	21
CW-7.2	Material Requirement.....	21
	CW-7.2.1 Bar Reinforcement.....	21
	CW-7.2.2 Sampling .....	22
CW-7.3	Construction Requirement.....	22
	CW-7.3.1 Order List for Bent Bars.....	22
	CW-7.3.2 Fabrication .....	22
	CW-7.3.3 Protection of Material .....	22
	CW-7.3.4 Placing and Fastening Reinforcement & Miscellaneous Material (ACI-301) .....	23
	CW-7.3.5 Splicing .....	24
CW-7.4	Measurement and Payment .....	25
<b>CW-8.0</b>	<b>STRUCTURAL STEEL.....</b>	<b>26</b>
CW-8.1	General .....	26
	CW-8.1.1 Submittals .....	26
	CW-8.1.2 Delivery and Storage.....	27
CW-8.2	Materials .....	27
	CW-8.2.1 Steel.....	27
	CW-8.2.2 Bolts, Nuts and Washers:.....	27
CW-8.2.3	Accessories:.....	28
CW-8.3	Execution .....	28
	CW-8.3.1 Fabrication .....	28

CW-8.3.2 Welding of Structural Steel Work: .....28

CW-8.3.3 Shop Painting .....28

CW-8.3.4 Erection.....29

CW-8.3.5 Tests and Inspections .....29

CW-8.4 Measurement and Payment.....30

**CW-9.0 DRAINAGE SYSTEM AND APPURTENANT STRUCTURES .....30**

CW-9.1 Scope.....30

CW-9.2 Materials .....30

    CW-9.2.1 Non-Reinforced Concrete Drainage Pipes.....30

    CW-9.2.2 Reinforced Concrete Drainage Pipes .....30

    CW-9.2.3 PVC Pipes.....31

    CW-9.2.4 Concrete Covered Rectangular Ditch.....31

    CW-9.2.5 Bedding Material.....31

CW-9.3 Construction .....31

    CW-9.3.1 Trench Excavation and Backfill.....31

    CW-9.3.2 Concrete Canal.....31

    CW-9.3.3 Appurtenant Structures .....32

CW-9.4 Pipe Installation .....32

    CW-9.4.1 General .....32

    CW-9.4.2 Non-Reinforced and Reinforced Concrete Drainage Pipes.....32

CW-9.5 Measurement and Payment.....33

    CW-9.5.1 Concrete Rectangular Ditch.....33

    CW-9.5.2 Concrete Drainage Pipes and PVC Pipes .....33

    CW-9.5.3 Appurtenant Structures .....33

    CW-9.5.4 Bedding .....33

**CW-10.0 GROUTING .....34**

CW-10.1 Scope.....34

CW-10.2 Physical Properties .....34

CW-10.3 Submittals .....34

CW-10.4 Measurement and Payment.....34

**CW-11.0 HIGH DENSITY POLYTHYLENE LINER .....34**

CW-11.1 Scope.....34

CW-11.2 Physical Properties .....35

CW-11.3 Submittals .....35

CW-11.4 Measurement and Payment.....35

---

<b>CW-12.0 DRAIN PIPES.....</b>	<b>35</b>
CW-12.1 Scope.....	35
CW-12.2 Physical Properties .....	35
CW-12.3 Submittals .....	34
CW-12.4 Measurement and Payment.....	35
<b>CW-13.0 PVC WATERSTOP .....</b>	<b>36</b>
CW-13.1 Scope.....	36
CW-13.2 Physical Properties .....	36
CW-13.3 Submittals .....	36
CW-13.4 Measurement and Payment.....	36

## TECHNICAL SPECIFICATIONS

### CW – CIVIL WORKS

#### **CW-1.0 GENERAL CONSTRUCTION FACILITIES**

##### **CW-1.1 Scope**

This section covers the construction and/or maintenance of access roads, drainage system and other appurtenant structures, moving-in of the Contractor's construction equipment, setting up of the Contractor's camp and the disposition of the Contractor's various facilities at the end of the Contract.

##### **CW-1.2 Moving-in**

The Contractor shall bring to the site all his necessary construction equipment and plant and install all stationary construction equipment and plant at location and in the manner approved by the NPC. The Contractor shall submit sufficient detailed plans showing the proposed location of such stationary equipment and plant and other pertinent data. No installation of such stationary equipment shall be undertaken unless the corresponding plans have been approved by the NPC.

##### **CW-1.3 Contractor's Camp Facilities**

The Contractor shall provide and grade his camp site, construct his camp, employee housing, warehouse, machine and repair shops, fuel storage tanks and provide such related facilities and sanitary conveniences that the Contractor deems necessary for maintaining health, peace and order in the camp and work areas. The areas that may be used by the Contractor within the plant site shall be designated by the NPC.

The Contractor shall provide, maintain and operate, under competent direction, such camps and facilities as are necessary for the housing, feeding and accommodation of his employees.

##### **CW-1.4 Water Supply**

The Contractor shall, at his own expense, be responsible for the supply, installation, operation and maintenance of a safe and adequate supply of drinking and domestic water. Whenever there is a possibility of contamination of the water supply for drinking and domestic purposes, chlorination or some other approved methods of sterilization shall be carried out. The installation and maintenance of these services shall be subject to the approval of the NPC.

**CW-1.5 Sewerage Disposal and Sanitation**

The Contractor shall, at his own expense, be responsible for the installation operation and maintenance of an adequate sewerage disposal and sanitation system and shall provide adequate toilet and wash-up facilities for his employees at his camp and in the areas where work is being carried out.

The Contractor shall execute the work with due regard to adequate sanitary provisions and applicable codes and shall take all necessary steps to prevent the pollution of water in any spring, river, or other sources of water supply. All toilets or wash-up facilities shall be subject to the prior and continuing approval of the NPC.

**CW-1.6 Fire Protection**

The Contractor shall observe all necessary precautions against fire, shall provide and maintain at his own expense, portable fire-fighting equipment he may deem necessary, and shall comply with all applicable laws of the Philippines relating thereto.

In the event of an uncontrollable fire occurring in the area of the Contractor's operation, the Contractor shall have to extinguish the fire immediately at his own expense, to the full extent of the manpower and equipment employed under the contract at the time of the fire.

The Contractor shall indemnify NPC against all liabilities, claims, damages and/or lawsuits arising thereto.

**CW-1.7 Construction Power**

The Contractor shall be responsible for providing his own electric power supply required for construction and erection/installation. If power is available from NPC and should the Contractor elect to utilize the NPC's power supply, he shall make an arrangement with NPC concerned group as to the billing rates and other requirements needed for direct connection to NPC.

**CW-1.8 Camp Security**

The Contractor shall provide his own security force to the extent that he deems necessary for maintaining peace and order in the camp and work areas and to safeguard materials and equipment. Nothing under the provisions of this paragraph shall relieve the Contractor from full responsibility for the maintenance of peace and order and protection of life and property in all areas where he operates.

**CW-1.9 Construction Material Storage**

The Contractor is required to put up warehouse(s) with capacities sufficient to store the construction materials required in the work. The warehouse(s) shall be specifically for this contract, notwithstanding his other facilities in the site that may serve the purpose.

**CW-1.10 Removal of Camp and Construction Facilities**

After the completion of the work covered by the contract and prior to acceptance of the completed work, the entire camp facilities of the Contractor, including its water supply system, electric distribution system, quarters, warehouses, shops, dining halls, commissaries, temporary shed and other facilities therein shall be removed by the Contractor. The site shall be cleared and cleaned as directed by the NPC.

**CW-1.11 Measurement and Payment**

No separate measurement and payment will be made for the Contractor's Construction Facilities. The entire cost thereof shall be included in the various pay items in the Bill of Quantities.

**CW-2.0 CARE OF WATER DURING CONSTRUCTION****CW-2.1 Scope**

In accordance with the specifications contained in this section or otherwise directed, the Contractor shall construct and maintain all necessary temporary drainage ditches and other temporary protective works and he shall also furnish, install, maintain and operate necessary pumping equipment and other devices to protect construction operations free from water coming from any source, including rain.

**CW-2.2 Drainage and Dewatering**

The Contractor shall be responsible for dewatering foundation areas so that work can be carried out on a suitably dry condition. The Contractor shall construct drainage ditches, holes, culverts, furnish, maintain and operate at his own expense all necessary pumps and other dewatering devices to keep all work areas free from water.

After the work is completed and before it is accepted by the NPC, the Contractor shall remove all pumping equipment and shall remove, fill or plug all temporary drainage structures as directed, all at his expense.

**CW-2.3 Measurement and Payment**

No separate measurement and payment will be made for the Care of Water During Construction operations. The cost of furnishing, constructing, maintaining, operating and removing of temporary drainage structures, pumping system and other dewatering devices necessary to keep construction operations free from water, shall be included in the various pay items in the Bill of Quantities for structures where such care of water is required.

**CW-3.0 ENVIRONMENTAL REQUIREMENTS FOR CIVIL WORKS****CW-3.1 Scope**

This section pertains to the environmental and safety provisions, requirements and conditions that shall govern during the execution of all civil works under this project.

**CW-3.2 General Conditions**

The Contractor shall ensure compliance with the applicable environmental and safety regulations, as well as ECC conditions, during installation/construction of this project through the implementation of measures that include, but not limited to, the following:

- a) Designate a Safety Officer and a Pollution Control Officer who shall respectively handle all safety and environmental concerns of the project.
- b) Prepare and submit Construction Safety and Health Plan (CSHP).
- c) Properly manage debris and various waste generated during installation/construction, such as the following:
  - Dispose of demolition and construction debris in a designated or NPC approved disposal area(s);
  - Stockpile (and cover if possible) or haul to the designated and/or pre-developed dump sites (spoil disposal areas) that shall be provided with suitable drainage – equipped with sediment traps, stripped top soil, spoils from quarry/borrow sites and excavated materials;
  - Segregate solid wastes, such as empty cement sacks, scraps of tin or wood, used wires and other domestic garbage, for recycling or storage in NPC-approved temporary storage areas and further disposal to LGU-designated disposal sites.
  - Properly handle, store and dispose-off, through DENR-accredited transporter/treater, hazardous wastes i.e. used oils, paints, thinner, etc.
- d) Limit construction activities that generate excessive noise to daytime works only to prevent nuisance to nearby residents during rest hours.
- e) As far as practicable, undertake site stripping, grading and excavations during dry weather.
- f) Construction/Installation shall be carried-out in a manner where landslides and erosions are minimized.



- g) Avoid unnecessary opening/clearing of areas outside construction sites or destruction of vegetative cover, especially cutting of existing trees; and to re-vegetate disturbed areas.
- h) Implement biological control measures such as maintenance of vegetation buffers (i.e. sodding of grass, planting of creeping vines, herbs, shrubs and trees) to shield streams/rivers from sedimentation; planting of vegetative cover over erodible surfaces; and planting of exposed sloping areas with shallow-rooted species like grasses, herbs or creepers.
- i) Locate fill slopes and spoil heaps away from drainage routes and properly remove/dispose the same as soon as practicable.
- j) Preserve or replace, if practicable, natural drainage patterns (when disturbed by civil works) with appropriate drainage channels.
- k) Convey oil-contaminated wastewater from workshops, garages, or gas filling stations through an oil trap (i.e. improvised oil-water separator) prior to discharge.
- l) Spray water, wherever and whenever necessary, to minimize dust generation.
- m) Provide PPEs and other safety provisions required by DOLE, for its project/site works.
- n) Take all necessary steps to prevent the pollution of groundwater and/or water bodies in the vicinity of the project site.

### **CW-3.3 Measurement and Payment**

No separate measurement and payment will be made for the Contractor's compliance to the foregoing. The entire cost thereof shall be included in the various pay items in the Bill of Quantities.

### **CW-4.0 SITE GRADING**

#### **CW-4.1 Scope**

In accordance with the specifications contained herein and in conformance with the lines, slopes, grades and extent shown on the plans or otherwise directed by the NPC, the Contractor shall furnish all equipment, labor and materials and shall perform the required grading work.

#### **CW-4.2 Clearing, Grubbing and Miscellaneous Work**

##### **CW-4.2.1 Clearing and Grubbing**

The Contractor shall perform clearing and grubbing on the project site. The site shall be cleared and grubbed of all trees and brush except particular trees,

which may be retained by the NPC for preservation. Particular trees to be left in place shall be protected from scarring and/or other injuries during clearing and grubbing work and other construction operations.

All stumps, roots and brush shall be removed to a depth of thirty (30) cm below original ground surface and disposed of in a place designated by the NPC. Downed timber, which may be ordered saved by the NPC for future use, shall be cut into logs as directed and neatly piled in a place designated by the NPC, otherwise they shall be disposed of same as above.

#### **CW-4.2.2 Miscellaneous Works**

Where shown on the drawings or if not shown but directed by the NPC, the Contractor shall perform miscellaneous work like demolition, removal, chipping, replacement or transfer of existing structures and other miscellaneous work. All demolished structures shall be disposed of as directed by NPC.

#### **CW-4.3 Grading**

##### **CW-4.3.1 General**

The word "grading" as defined herein means bringing to required grades all areas in accordance with the lines, slopes, elevations and grades shown on the drawings or as directed by the NPC.

##### **CW-4.3.2 Classification of Materials**

All materials in grading work shall be unclassified regardless of the nature of materials encountered during grading excavation and of materials used in grading fill. It is on the basis of unclassified material that Contractor shall determine his unit bid price for grading excavation and grading fill.

##### **CW-4.3.3 Stripping**

Fill areas to be brought to grade shall first be stripped of their top soil as directed but in no case less than twenty (20) centimeters in depth and disposed of properly in spoil areas designated by the NPC. Only materials from grading excavation and intended to be used for filling or backfilling purposes shall be stripped of top soil in the same manner as above.

##### **CW-4.3.4 Excavation and Fill**

Areas required to be brought to grade shall be excavated or filled as the case may be. Grading work shall be carried out in such a manner that the free drainage is maintained at all times and nowhere shall pondage be found in any part of the work.

The NPC may require the modification of slopes and grades according to the conditions actually encountered during excavation, but such change or modification shall not be construed to mean by the Contractor as a basis for additional compensation over and above the contract unit prices.

Any over-excavation performed by the Contractor for any purpose or reason, except as may be ordered by the NPC, shall be at the Contractor's expense and any excess of excavation shall be refilled, where required, with approved materials that shall be furnished, placed and properly compacted at the expense of the Contractor.

Unsuitable materials, as determined by the NPC, which may be encountered below established grade, shall be removed to a depth as directed and accordingly replaced with suitable materials approved by the NPC. The removal and proper disposal of such unsuitable materials shall be paid for at the contract unit price for the item, Grading Excavation, and payment for placing and compacting suitable material be made at the contract unit price for the item, Grading Fill, in the Bill of Quantities.

Fill work shall not be started until the area has been inspected and approved by the NPC after stripping. Grading fill shall be spread and compacted in layers of 15 cm. loose volume and compacted with approved roller weighing not less than 10 tons. Each layer shall be moistened or dried as directed for maximum compaction. No succeeding layer shall be placed thereon unless the preceding layer has been tested for compaction and approved by the NPC.

In the event that construction of concrete footing or other concrete foundations is on fill, the fill shall be compacted efficiently and thoroughly so that when the fill is tested for compaction at the required foundation elevation for the structure, the required bearing capacity is attained but in no case less than 17.24MPa. In no case shall filling and compaction work to be done without the presence of NPC's inspectors. The Contractor shall be held liable for any structural instability or damage that might result in consequence to non-compliance of this requirement. The Contractor shall institute corrective measures to bring the foundation base to a condition or state that will conform to the required bearing capacity; and also to repair and make good any damage on the structure to the satisfaction and at no cost to NPC.

#### **CW-4.3.5 Slides**

In the event that slides occur along excavated slopes during grading operations or after completion of grading but prior to acceptance of the work, the Contractor shall remove and dispose the slide materials and also to trim the slopes as directed to leave the slopes in a safe and neat condition all at no additional cost to NPC, unless occurrence of such slides is occasioned by causes beyond control of the Contractor. In such event, payment for the satisfactory removal and proper disposal of slide material and finishing and rounding of slopes will be paid for at the equivalent of thirty percent (30%) of the contract unit price per cubic meter for the item Grading Excavation.

#### **CW-4.3.6 Slip-Outs**

In the event of slip-outs in any part of the grading fill prior to final acceptance of the work, the Contractor shall rebuild such portion of the fill. In the case it is determined that the slip-outs was caused through the fault of the Contractor, the rebuilding of the fill shall be performed by the Contractor at no extra cost to

NPC; otherwise, the reconstruction of the fill will be paid for thirty percent (30%) of the contract unit for the item, Grading Fill.

**CW-4.4 Disposal**

All excess materials from grading work (including excess materials in structural excavation and miscellaneous work) shall be disposed of by the Contractor. The acquisition of the right-of-way for the area of disposal including the access thereto, permits, and other requirements, shall be the responsibility of the Contractor at no cost to NPC. The Contractor shall be held solely liable for any claim by third parties that may arise from improper transport and disposal of excess materials. The cost of acquisition of the above-mentioned right-of-way shall be included in the unit bid price for excavation.

**CW-4.5 Sources of Fill Materials**

When suitable materials from grading excavation are deficient to meet the quantity required for grading fill, additional fill materials shall be obtained from other sources proposed by the Contractor and approved by the NPC. Cost of excavating, hauling, placing and compacting additional materials from borrow sources shall be included in the unit price bid for the item, Grading Fill. Acquisition of right-of-way to these sources shall be the responsibility and account of the Contractor.

**CW-4.6 Environmental Requirements**

All construction activities to be performed by the Contractor shall be in accordance with the restrictions stated in the approved Environmental Clearance Certificate (ECC) and the conditions set forth in Clause 3.0 – Environmental Requirements for Civil Works.

**CW-4.7 Measurement and Payment**

**CW-4.7.1 Clearing and Grubbing**

Unless otherwise specified in the bill of quantities, no separate measurement and payment will be made for Clearing and Grubbing. Corresponding cost hereof shall be included in the unit bid price of relevant item(s) in the bill of quantities.

**CW-4.7.2 Miscellaneous Works**

Measurement for payment for miscellaneous work such as demolition, restoration, etc., shall be made on a lot basis unless otherwise specified in the bill of quantities. Payment will be made at the contract unit price for the item Miscellaneous Works, which payment shall cover all cost for furnishing labor, equipment and incidentals necessary for demolition and restoration, disposal, and other related works required to complete the item.

**CW-4.7.3 Stripping**

Unless otherwise specified in the bill of quantities, no separate measurement and payment will be made for Stripping. Corresponding cost hereof shall be included in the unit bid price of relevant item(s) in the bill of quantities.

**CW-4.7.4 Grading Excavation**

Measurement for payment for Grading Excavation shall be based on the number of cubic meters excavated and properly disposed. Volume shall be computed by the average end area method which shall be the volume between the original ground (as determined by survey to be made by representatives of both NPC and the Contractor) and graded surface on the drawings or as established by NPC. To this volume shall be added, for purpose of payment, all authorized excavations below grade.

Payment will be made at the contract unit price for the item Grading Excavation in the Bill of Quantities, which payment shall constitute full compensation for furnishing of all labor, construction equipment and incidentals necessary excavate, dispose and other related work required to complete the work item.

**CW-4.7.5 Grading Fill**

Measurement for payment for Grading Fill shall be based on the number of cubic meters of the materials placed, graded, compacted and accepted. Volume shall be computed by the average end area method which shall be the volume between the ground surface after stripping and the finished grade surfaces on the drawings or as established by NPC.

Payment will be made at the contract unit price for the item Grading Fill in the Bill of Quantities, which payment shall constitute full compensation for furnishing of all materials, labor, construction equipment and incidentals necessary to complete the work item.

**CW-5.0 STRUCTURAL EXCAVATION, FILL AND BACKFILL****CW-5.1 Scope**

In accordance with the specifications contained herein and as shown on the drawings and otherwise directed, the Contractor shall perform all the required structural excavation, fill and backfill for the entire project, including the proper disposal of excess excavated materials.

**CW-5.2 Materials****CW-5.2.1 Structural Excavation**

No classification will be made on the materials excavated. The Contractor shall determine his/her unit bid price for structural excavation based on unclassified material regardless of the nature of the materials actually encountered and excavated.

**CW-5.2.2 Structural Fill**

a. Sand and Gravel Fill

The material shall be of the same classification as the sand and gravel base consisting of river sand and gravel as approved by the NPC. The composite material shall be free from vegetable matter and lumps or balls of clay, and shall be uniformly graded from coarse to fine in accordance with the grading requirements shown below:

<b>Sieve Designation (Square Mesh Sieves)</b>	<b>Percentage by Weight Passing</b>
50.0 mm (2")	100
25.4 mm (1")	55-85
9.5 mm (3/8")	35-60
4.76 mm (No. 4)	25-50
2.08 mm (No. 10)	20-40
0.42 mm (No. 40)	8-20
0.074 mm (No. 200)	2-8

b. Structural Earth Fill

Structural earth fill shall consist of filling with suitable materials obtained from grading excavation or from borrow areas approved by the NPC.

**CW-5.2.3 Special Foundation, if any**

The NPC shall have the option to use one or both of the following materials for special foundations, whether or not shown on the drawings:

a. Lean Concrete

The strength of lean concrete shall be 13.79MPa or as designated by the NPC.

b. Selected Materials

Selected materials shall consist of compactable material which, when compacted, shall attain the required bearing capacity. The material could be a combination of earth and rock particles not greater than 8 cm including sandy clay, gravelly clay, or shale, all approved by the NPC.

Bed materials for water pipes and/or drainage culverts shall use sand fills.

**CW-5.2.4 Structural Backfill**

Backfill for Structures Other Than Pipes – Material for backfill shall consist of compactable and approved material taken from grading and structural excavations. Any additional material needed shall be obtained from borrow areas proposed by the Contractor and approved by the NPC.

Backfill for Sewerage and Drainage Pipes – The layer of backfill materials immediately above, up to 60 cm. from the top of pipe, and on the sides of the pipe shall consist of selected material consisting of clay soil and/or other fine materials that are free from stone particles, roots, debris. The upper layer shall consist of compactable materials taken from pipe trench and other structural excavation.

Backfill for Water Supply Pipes – Backfill for water supply pipes shall consist of compactable materials taken from trench excavation and approved by the NPC.

**CW-5.3 Construction**

**CW-5.3.1 Excavation**

a. General

The Contractor shall notify the NPC sufficiently in advance before the beginning of any excavation so that a joint survey for baseline data and cross-sectional measurements can be undertaken on the undisturbed/natural ground surface. All excavation shall be carried out according to the lines, slopes and grades shown on the drawings. In case an increase or decrease in quantities occur as a result of changes made by the NPC to such lines, slopes, and grades, the provisions on Variation Orders under the General Conditions of Contract (GCC) shall apply.

After each excavation is completed or where replacement of unsuitable material below required foundation grade has been undertaken, the Contractor shall notify the NPC so that proper inspection and confirmatory test on the bearing capacity of the foundation material can be made. In no case that concrete, sewer, drainage or water supply pipe can be placed unless a written approval has been issued by the NPC.

Over-excavation performed by the Contractor due to his carelessness shall be filled and properly compacted with the suitable material approved by NPC, at no additional cost to NPC.

b. Structural Excavation, Structure Other Than Pipes

The Contractor shall excavate the foundations to the specified side slopes and depths shown on the drawings, after which the NPC will conduct tests on the underlying material below foundation grade to determine the actual bearing capacity at such depth. If the required bearing capacity is not attained, the NPC shall instruct the Contractor to excavate further down until, in the opinion of the NPC, the bearing capacity is adequate to sustain the applied load on the foundation.

Compliance to such instruction shall not entitle the Contractor for additional compensation over and above the unit prices for excavation regardless of the nature of material excavated. For purposes of measurement, the applicable paylines for the excavation under this condition or situation shall be as shown on the drawings that show the paylines for excavation and special foundation materials.

c. Drainage and Sewerage Pipes and Cable Trench

The width of trench excavation for drainage and sewerage pipes and cable trench shall be as indicated on the drawings. All trench bottoms shall be excavated to the foundation grade indicated, regardless of the foundation material classification.

d. Water Supply Pipes

Trenches for main or feeder lines shall be excavated to the depth of no less than 0.25 meter on open ground and 0.60 meter under roadways and parking areas, both depths measured from the finished grade surface.

Service pipes shall be buried to a depth of at least 0.15 meter below grade line.

**CW-5.3.2 Structural Foundation Fill**

No fill materials shall be placed in any part of the fill foundation unless the foundations have been inspected and approved by the NPC. Fill materials shall be placed and spread in layer covering the entire length and breadth of the section under construction, each layer not to exceed 15 cm. in loose volume thickness and compacted thoroughly to the desired compaction as determined by the NPC. No succeeding layer shall be placed until the previous layer has been tested and approved, as to compaction, by the NPC.

**CW-5.3.3 Special Foundations**

If unsuitable material is encountered or if the foundation material is unsuitable such that the required bearing capacity of the foundation cannot be attained at the required elevation, further excavation shall be performed by the Contractor as stated in CW-5.3.1b.

Excavated materials below foundation grade shall be replaced at the direction of the NPC, either by lean concrete or by selected materials as mentioned in CW-5.2.3.

Selected materials shall be placed in 15-cm layers and compacted until the required bearing capacity is attained.

**CW-5.3.4 Backfill**

1. Structures, Other Than Pipes

Excavated areas around structures for backfilling shall be backfilled with approved materials in horizontal layers, each not exceeding 15cm. (6") in loose volume thickness. Each layer shall either be moistened or dried as directed and thoroughly tamped with tampers having no less than 160 cm<sup>2</sup> of tamping area and weighing not less than 20 kg. The last layer shall be neatly brought up to the level of the adjoining finished grade surface.



In no case shall backfill be placed around concrete structures until after fourteen (14) days from placement of the concrete.

## 2. Drainage and Sewerage Pipes

After the pipes have been installed and grouted joints sufficiently cured, but in no case less than seven (7) days allowed for curing as specified in NSCP and the whole pipeline inspected, backfill materials specified herein shall be placed in layers as directed, each layer either dried or moistened as directed and thoroughly tamped. The backfill shall be brought up evenly on both sides of the pipe up to the top of the pipe and finally up to the finished grade surface.

## 3. Water Supply Pipes

After the pipeline has been installed and tested it shall be backfilled in layers as directed and compacted to the satisfaction of the NPC.

### **CW-5.4 Measurement and Payment**

#### **CW-5.4.1 Structural Excavation**

Measurement for payment for structural excavation performed by the Contractor for structures (except drainage, sewerage and water supply pipes, and appurtenances of which cost of excavation and backfill is included in the cost of installed pipe and constructed appurtenances) will be based on the number of cubic meters of materials excavated.

For purpose of payment, all authorized excavation below foundation grade (like in the case of unsuitable materials encountered) shall be included in the measurement.

Payment will be made at the contract unit price for Structural Excavation in the Bill of Quantities, which payment shall constitute full compensation for furnishing all labor and equipment necessary for excavation work and proper disposal of excess material excavated.

#### **CW-5.4.2 Structural Foundation Fill**

Measurement for payment for Structural Foundation Fill will be based on the number of cubic meters of fill materials placed within the neat lines as shown on the drawings.

Payment will be made at the contract unit price for the item, Sand and Gravel Fill/Base, in the Bill of Quantities, which payment shall constitute full compensation for furnishing, placing and compacting fill materials; labor which include spreading, compacting, etc., equipment and other incidentals necessary to complete the item.

**CW-5.4.3 Special Foundations**

Measurement for payment for lean concrete and/or selected materials placed within the pay lines for excavation will be based on the number of cubic meters in-place and accepted.

Payment will be made at the contract unit price for the corresponding item shown in the Bill of Quantities, which payment shall cover all costs for furnishing all labor, materials, equipment and tools necessary to complete the item.

**CW-5.4.4 Structural Backfill**

Measurement for payment for Structural Backfill (except backfill for drainage and sewerage pipes, appurtenances and other structures of which cost of backfill is included in the cost of installed pipes and appurtenances) will be based on the number of cubic meters of approved materials, backfilled, satisfactorily compacted and accepted. Any backfill material placed outside the pay lines for excavation to replace slides or over-excavation will not be paid.

Payment will be made at the contract unit price for the item, Structural Backfill, in the Bill of Quantities, which payment shall constitute full compensation for furnishing all labor, materials and equipment necessary for backfilling work.

**CW-5.4.5 Trench Excavation and Backfill for Sewerage, Drainage and Water Supply Pipes and Cable Trench**

No separate measurement and payment will be made for trench excavation and backfill for all sewerage, drainage and water supply pipes. Payment for trench excavation and backfill for pipes shall be included in the payment pertaining to pipes as shown in the Bill of Quantities.

**CW-6.0 CONCRETE****CW-6.1 Scope**

In accordance with the specifications contained in this section, the Contractor shall furnish all materials, labor, equipment and tools and perform all concreting works in accordance with the drawings, or as otherwise directed.

**CW-6.2 Class of Concrete**

Class of concrete or strength shall be as indicated on the drawings, which shall conform to the minimum requirement for compressive strength indicated on the provision of NSCP for Concrete and, in no case, shall not be less than 20.7 MPa.

**CW-6.3 Materials****CW-6.3.1 Cement**

Cement for concrete works shall be furnished by the Contractor and shall conform to the requirements of the latest edition of the Standard Specifications for Portland Cement (ASTMC150).

Unless otherwise specified, cement shall be ordinary Portland Cement. Type I for general construction which concrete is not in contact with soils or ground water and Type II for concrete in contact with soil or ground water.

Changing of brand or type of cement within the same structure will not be permitted unless with prior permission and approval obtained from the NPC.

**CW-6.3.2 Reinforcing Steel**

The Contractor shall furnish all reinforcing steel of the sizes shown on the drawings and in accordance with the herein specifications for reinforcing steel.

**CW-6.3.3 Water**

Water for use in concrete shall be subject to the approval of the NPC. It shall not be salty and shall be reasonably clear and free from oil, acid, injurious alkali or vegetable matter.

**CW-6.3.4 Aggregates**

All coarse and fine aggregates shall consist of hard, tough, durable and clean, uncoated particles. All foreign materials and dust shall be removed by processing. Aggregates shall generally be rounded and reasonably free from thin, flat and elongated particles in all sizes and well graded from coarse to fine.

**CW-6.3.5 Formwork**

Timber, lumber and plywood to be used for falsework and formwork shall be sound and shall comply with the requirements of this specifications. Use forms where a smooth form finish is required. Lumber shall be square-edged or tongue-and-groove boards, free or raised grain, knotholes and the other surfaces defects. Steel when used shall conform to the requirements of the ASTM A36. Steel form surfaces shall not contain irregularities, dents, or sags.

Forms shall be wood, plywood, or steel. Wood forms for surfaces exposed to view in the finished structure and requiring a smooth form finish, shall be plywood. For unexposed surfaces, undressed square-edge lumber may be used. Forms for surfaces requiring special finishes shall be plywood, or shall be lined with plywood, a non-absorptive, hard-pressed fiberboard, absorptive-type lining or other suitable material. Plywood, other than for lining, shall be concrete-form plywood free of raised grain, torn surfaces, worn edges, patches, or other surface defects, which would impair the texture of the concrete surface. Surfaces of steel forms shall be free from irregularities, dents, and sags.

**CW-6.4 Storage of Materials****CW-6.4.1 Cement and Aggregates**

All cement shall be stored, immediately upon delivery at the Site, in weatherproof building that will protect the cement from dampness. The floor shall be adequately raised from the ground and in buildings placed in the locations approved by NPC. Provisions for storage shall be ample, and the shipments of cement as received shall be separately stored in such a manner that allows the earliest deliveries to be used first and to provide easy access for identification and inspection of each shipment. Storage buildings shall have capacity for storage of sufficient quantity of cement to allow sampling at least twelve (12) days before the cement is to be used. Bulk cement, if used, shall be transferred to elevated air tight and weatherproof bins. Stored cement shall meet the test requirements at any time after storage when NPC orders retest. At the time of use, all cement shall be free flowing and free of lumps.

Handling and storing of concrete aggregates shall be such that segregation or inclusion of foreign materials is sufficiently prevented. NPC may require that aggregates be stored on separate platforms at satisfactory locations.

In order to secure greater uniformity of concrete mix, NPC may require that the coarse aggregate be separated into two or more sizes. Different sizes of aggregates shall be stored in separate bins or in separate stockpiles and relatively away from each other to prevent the material at the edges of the piles from intermixing.

**CW-6.4.2 Reinforcing Steel**

Reinforcing steel shall be stored in accordance with the specifications for reinforcing steel.

**CW-6.5 Concreting****CW-6.5.1 General**

The written approval of the NPC shall be secured prior to any concreting work. All concrete shall be poured on dry and cleaned surfaces.

**CW-6.5.2 Formwork Construction**

Forms shall be installed mortar and watertight, true to the dimensions, lines and grades of the structure and with the sufficient strength, rigidity, shape and surface smoothness as to leave the finished works true to the dimensions shown on the drawings or required by NPC and with the surface finish as specified.

The inside surfaces of forms shall be cleaned of all dirt, mortar and foreign material. Forms, which will subsequently be removed, shall be thoroughly coated with a release agent or coating prior to its use. The release agent shall be commercial quality form oil or other approved coating which will permit the ready release of the forms and will not discolor the concrete.

Formwork for concrete placed underwater shall be watertight.

Forms shall be constructed so that the form surface of the concrete does not undulate excessively in any direction. Undulations exceeding either 2 mm or 1/270 of the center distance between studs, joints, form stiffeners, form fasteners, or wales will be considered to be excessive. Should any form of the forming system, even though previously approved for the use, produce a concrete surface with excessive undulations, its use shall be discontinued until modifications, satisfactory to NPC's Representative, have been made.

Portions of concrete structures with surface undulations in excess of the limits herein stated may be rejected by the NPC.

Form fasteners consisting of bolts, clamps or other devices shall be used as necessary to prevent spreading of the forms during concrete placement. The use of ties consisting of twisted wire loops to hold the forms in position will not be permitted.

All formworks shall be provided with adequate clean-out openings to permit inspection and easy cleaning after all reinforcement has been placed. Where forms for continuous surfaces are placed in successive units, the forms shall be fitted over the completed surface to obtain accurate alignment of the surface and to prevent leakage of mortar. Panel forms shall be constructed so that they can be removed without damaging the concrete. All exposed joints, edges, and external corners shall be chamfered a minimum of 20 mm unless specified otherwise herein. Forms for heavy girders and similar members shall be constructed with a proper camber.

Coating: Before placing the concrete, the contact surface of forms shall be coated with a non-staining mineral oil or suitable non-staining form coating compound or shall be given two coats of nitrocellulose lacquer, except as specified otherwise. Mineral oil shall not be used on forms for surfaces, which are to be painted. For surfaces not exposed to view in the finished structure, sheathing may be wetted thoroughly with clean water. All excess coating shall be removed by wiping with cloths. Reused forms shall have the contact surfaces cleaned thoroughly. Those that have been coated shall be given an additional application of the coating. Plaster waste molds shall be layered with two coats of the thin shellac or lacquer and coated with soft or thinned non-staining grease.

Tolerance and Variations: The Contractor shall set and maintain concrete forms to ensure that, after removal of the forms and prior to patching and finishing, no portion of the concrete work will exceed any of the tolerances specified. Variations in floor levels shall be measured before removal of supporting shores. The Contractor shall make the necessary corrective measures for the variations resulting from deflection, or when the latter affects concrete quality or curing. The tolerances specified shall not exceed by any portion of the concrete surfaces; the specified variation for one element of the structure shall be considered unacceptable when it permits another element of the structure to exceed its allowable variations. Except as otherwise specified herein, tolerances shall conform to ACI 347.

**CW-6.5.3 Placing Reinforcement**

Reinforcing steel and embedded items shall be properly and securely installed prior to the placing of concrete.

In no case shall concreting start without prior inspection and approval by the NPC of the placed reinforcement and other embedded items.

**CW-6.5.4 Mixing Concrete**

Mixing of concrete shall conform to the requirements of ACI Code for Concrete Construction.

**CW-6.5.5 Placing Concrete**

Concrete shall be conveyed from mixers to the forms or to the place of deposit as rapidly as possible and by methods that will prevent segregation or loss of ingredients. There shall be no vertical drop greater than 1.5 meters except where suitable equipment like metal pipe or tremie is used. The pipe or tremie shall be kept full of concrete and its end shall be kept buried in the newly placed concrete. Chutes through which concrete is delivered to the structure in a thin, continuously exposed flow will not be permitted except for very limited or isolated sections of the work.

Earth surfaces, upon which concrete shall be placed, shall be cleaned, dry and thoroughly compacted before placing the concrete.

Rock surface, upon which concrete shall be placed, shall be thoroughly cleaned of loose or semi-detached or unsound rock particles. Before placing concrete, all surfaces shall be wetted thoroughly to keep them in a completely moist condition, after which leveling mortar of the same cement ratio as the concrete mix complete contact between concrete and the leveled surface.

**CW-6.5.6 Finishing Concrete**

After the concrete has been deposited, distributed and vibrated, the concrete shall be struck off and screened by mechanical means approved by the NPC. The finishing machine shall be of the screening and troweling type designed and operated both to strike off and to consolidate. Hand finishing may be employed when suitable finishing machines are not available. Finishing of concrete shall be done, as directed, to the satisfaction of the NPC.

All finished surfaces shall be tested with 3 meters straight edge and any variation of the surface from the desired crown or cross section shall be properly corrected.

**CW-6.5.7 Removal of Forms**

Formwork shall not be removed without the permission of NPC; where such permission, however, shall not relieve the Contractor of its responsibility for the safety of the work. Blocks and bracing shall be removed at the time the forms

are removed and in no case shall any portion of the wood forms be left in the concrete.

Falsework removal for continuous structures shall be as directed by NPC but in which case shall be temporarily supported such that the structure is gradually subjected to its working stresses. False work shall not be released in any span until the strength specified hereunder is attained.

When concrete strength tests are to be used as basis for the removal of forms and supports, the compressive strength of concrete must meet the following minimum requirements:

	Min. Time	Min.% Strength
Centering under girders and beams	14 days	80%
Sides of beams and all vertical surfaces	1 day	70%
Floor Slabs	14 days	80%

The site shall be cleared of all debris and refuse resulting from work.

**CW-6.5.8 Curing and Protection**

Concrete shall be cured for a period of not less than fourteen (14) consecutive days by keeping the surfaces of concrete continuously (not periodically) wet. Where tongue and groove forms were used and left in place of curing, they shall be kept wet at all times prevent opening at the joints and drying out of the concrete.

**CW-6.5.9 Sampling and Testing of Concrete**

The Contractor shall furnish all materials, either separately or mixed, as required by NPC. Selection of materials and the making of test specimens shall be made under the supervision of NPC and delivered to NPC laboratory or any NPC-accredited testing agency at the Contractor's expense.

The expense of making and curing all concrete specimens including the materials comprising the concrete specimens shall be borne by the Contractor. The cost of shipping and testing the concrete shall likewise be at the expense of the Contractor.

No concreting work on the project will be permitted to be done until NPC signifies in writing that, following the performance of the necessary tests, he gives his approval to the use of all materials involve in making the concrete.

As work progresses, test cylinders shall be fabricated from the concrete samples and tested in accordance with ASTM C31 and ASTM C39. At least one set of four (4) cylinders shall be made from each 10 cu.m of the concrete placed of each class. Also at least one set shall be made per day for each class of concrete placed each day.

Two (2) cylinders shall be tested at 28 days for specification compliance and one shall be tested at 7 and 14 days respectively for information. The acceptance test result shall be the average of the strength of the two cylinders tested at 28 days.

The compressive strength of the concrete shall be deemed acceptable if the averages of the three consecutive strength test results is equal to or exceeds the specified strength and no individual test falls below the specified strength by more than 3.50 MPa.

Concrete deemed to be not acceptable using the above criteria maybe rejected unless the Contractor can provide evidence, by means of core tests, that the quality of concrete represented by the failed test result is acceptable in place. Three (3) cores shall be taken in accordance with ASTM C42 and soaked for 24 hours prior to testing. Concrete in the area represented by the cores will be deemed acceptable if the average strength of the cores is equal to at least 85% of and no single core is less than 75% of the specified strength.

#### **CW-6.5.10 Tolerances and Repair for Concrete Construction**

Concrete structures shall be constructed to the lines shown on the drawings or where so required to suit actual field requirements. Any structure that does not conform to such lines shall be repaired or removed and made anew by the Contractor at no additional cost to the Corporation.

Repairs shall be made at surface imperfections due to faulty placing of concrete and cuts on the structures due to the removal of excess concrete on the lines shown on the drawings. Such repairs shall be made immediately after early stripping of the forms, after the imperfections have been identified and the methods of repair appropriately established.

#### **CW-6.5.11 Second Stage Concrete**

The second stage of concrete finishing shall be done only after the final installation of all pertinent equipment, anchorages, pipings, conduits and other embedded items as may be required for all electromechanical works.

#### **CW-6.6 Measurement and Payment**

Measurement for payment for Concrete, except concreting works that are associated to various construction and/or installation/erection works (i.e. equipment foundation and pedestals, perimeter wall footing and posts, etc.) included in the Bill of Quantities under separate pay item, will be based on the volume of concrete placed and accepted within the neat lines of the structure as shown on the drawings or in accordance with the manner of measurement set forth in the various sections of the Technical Provisions. No deduction will be made for rounded or beveled edges or space occupied by the metal items 10 sq. cm. or less in cross section, embedded in concrete.

Payment will be made at the corresponding contract unit price for the various items of concrete shown in the Bill of Quantities. Payment shall cover all costs



for furnishing all labor, materials, including equipment and tools required for concreting work. Payment shall also include non-shrink cementitious grout and epoxy grout inside foundation block out and above engine base plate and care of water.

No separate measurement for payment will be made for formworks of which the cost shall be included in concreting works.

## **CW-7.0 REINFORCING STEEL**

### **CW-7.1 Description**

This work shall consist of furnishing, fabricating, and placing of steel reinforcement of the type, size, shape and grade required in accordance with these specifications and in conformity with the requirements shown on the Drawings or as directed by the NPC.

### **CW-7.2 Material Requirement**

All material shall conform to the requirements hereinafter given. Certified test reports (mill test or other) shall be submitted to the NPC for all reinforcement steel used. These tests shall show the results of all chemical and physical tests made.

#### **CW-7.2.1 Bar Reinforcement**

Reinforcement bars for concrete shall be hot-rolled, weld able, deformed billet-steel bars conforming to the requirements specified in ASTM A615 and PNS 49 unless shown on the Drawings or as required by the NPC. The use of the cold twisted bars is not permitted. Bar reinforcement shall be shipped in standard bundles, tagged and marked in accordance with the Code of Standard Practice of the Concrete Reinforcement Steel Institute.

#### **CW-7.2.2 Sampling**

The NPC's Representative will sample reinforcement bars at the source of supply or at the point of distribution, and the Contractor shall notify the NPC in sufficient time in advance to permit sampling and testing before shipment is made. Three (3) samples from each size shall be taken at random representing five (5) tons or fraction thereof of each size.

### **CW-7.3 Construction Requirement**

#### **CW-7.3.1 Order List for Bent Bars**

Before materials are ordered, the Contractor shall furnish all order lists and bending diagrams for the approval of the NPC. The approval of order lists and bending diagrams by the NPC shall in no way relieve the Contractor of responsibility for the correctness of such lists and such lists and diagrams. Any expenses incident to the revisions of materials furnished in accordance with

such lists and diagrams to make them comply with the drawings shall be borne by the Contractor.

Shop Drawings for Reinforcing Steel (ACI 315): Indicate bending diagrams, assembly diagrams, splicing and laps of bars, shapes, dimensions and details of bar reinforcing, accessories and concrete cover. Do not scale dimensions from structural drawings to determine lengths of reinforcing steel.

#### **CW-7.3.2 Fabrication**

Bent bar reinforcement shall be cold bent as shown on the drawings or as required by the NPC. Bars shall be bent around circular pin having the following diameters (D) in relation to the diameter of the bar (d):

Bars 6mm $\Phi$ to 20mm $\Phi$ inclusive	D=6d
Bars 25mm $\Phi$ and 28mm $\Phi$	D=8d
Bars 32mm $\Phi$ and greater	D=10d

Bends and hooks in stirrups and lateral ties may be bent to the diameter of the principal bar enclosed therein.

#### **CW-7.3.3 Protection of Material**

Steel reinforcement shall be protected at all times from injury. When placed in the work, it shall be free from dirt, detrimental scale, paint, oil or other foreign matter. However, when steel has on its surface easily removable and detrimental rust, loose scale or dust, it shall be cleaned by a satisfactory method, approved by the NPC.

Store reinforcement of the different sizes in racks raised above the ground with accurate identification. Protect reinforcing steel from contaminants such as grease, oil and dirt.

#### **CW-7.3.4 Placing and Fastening Reinforcement & Miscellaneous Material (ACI-301)**

All reinforcement bars, stirrups, hanger bars, wire fabric, spirals and other reinforcing materials shall be provided as indicated in the drawing or required by the specification, together with all necessary wire ties, chairs, screws, supports, and other devices necessary to install and secure the reinforcement properly. All reinforcement, when placed, shall be free from rust, scale, oil, grease, clay, and other coatings, and foreign substances that would reduce or destroy the bond. Rusting of reinforcement shall not reduce the effective cross sectional area of the reinforcement to the extent that the strength is reduced beyond specified values. Heavy, thick rust or loose, flaky rust shall be removed by rubbing with burlap or other approved method, prior to placing. Reinforcement that has bends not shown on the project drawings or on approved shop drawings, or is reduced in section by rusting such that its weight is not within permissible ASTM tolerances, shall not be used. All reinforcement shall be supported and wired together to prevent displacement by construction loads or by the placing of concrete. Unless directed otherwise by the NPC,

reinforcement shall not be bent after being partially embedded in hardened concrete. Detailing of reinforcing shall conform to ACI 315. Where cover over reinforcing steel is not specified or indicated, it shall be in accordance with ACI 318.

All steel reinforcement shall be accurately placed in position shown on the drawings or as required by the NPC and firmly held there during the placing and setting of the concrete. Bars shall be tied at all intersections except where spacing is less than 30 mm in each direction, when alternate intersections shall be tied. Ties shall fasten on the inside.

Distance from the forms shall be maintained by means of stays, blocks, hangers or other approved supports. Blocks for holding reinforcement from contact with the forms shall be pre-cast mortar blocks of approved shape and dimensions or approved chairs. Layers of bars shall, be separated by pre-cast mortar blocks or by other equally suitable devices. The use of pebbles, pieces of broken stone or brick, metal pipe and wooden blocks or metal chairs shall not be permitted. Unless otherwise shown on the Drawings or required by the NPC, the minimum distance between bars shall be 40mm. Reinforcement in any member shall be placed and then inspected and approved by the NPC before the placing of concrete commences. Bundled bars shall be tied together at not more than 1.80 meters intervals.

Reinforcement shall be placed accurately and secured. It shall be supported by suitable chairs and spaces or by metal hangers. On the ground, and where otherwise subject to corrosion, concrete or other suitable non-corrodible material shall be used for supporting reinforcement. Where the concrete surface will be exposed to the weather in the finished structure or where rust would impair the appearance or finish of the structure, all reinforcement supports, within specified concrete cover, shall be galvanized or made of a suitable non-corrodible material.

All placement or movement of reinforcing steel after placement, to positions other than indicated or specified, shall be subject to the approval of the NPC.

Concrete protection for reinforcement shall be as indicated, or if not indicated, in accordance with ACI 318.

The minimum concrete cover for reinforcement specified in the bid documents shall takes precedence over all permissible reinforcement placement variations; nothing in the variations listed below is to be constructed as permitting violation or compromise thereof:

- |  |                 |
|--|-----------------|
| a. Height of bottom bars                 | ±6mm above form |
| b. Lengthwise positioning                | ±50mm of bars   |
| c. Spacing bars in walls and solid slabs | ±25mm           |
| d. Spacing bars in beams and footings    | ±6mm            |
| e. Height of top bars                    | ±6mm            |
| f. Stirrup spacing:                      |                 |

- (1) For any one stirrup ±25mm
- (2) For over-all group ±25mm of stirrup

Anchors and bolts; including but not limited to those for the machine and equipment bases; frames or edgings, hangers and inserts, door bucks, pipe supports, pipe sleeves, pipe passing through walls, metal ties, conduits, flashing reflects, drains and all other materials in connection with the concrete construction shall, where practicable be placed and secured in position when the concrete is placed. Anchor bolts for machines shall be set to templates, shall be plumbed carefully and checked for location and elevation with an instrument, and shall be held in position rigidly to prevent displacement while concrete is being placed.

**CW-7.3.5 Splicing**

Splicing of reinforcement shall be in accordance with ACI 318, except as indicated otherwise or modified herein. Where splices in addition to those indicated on the drawings are necessary, they shall be approved by the NPC prior to their use. Splices shall not be made in beams, girders, and slabs at points of maximum stress. Butt Splicing shall preferably be used over lapping for bar sizes larger than 32 mmΦ. Splices to be welded shall conform to AWS D1.4; certification of weld ability of the reinforcement by the manufacturer, shall be submitted to the NPC. If the Contractor elects to use butt splicing of reinforcing, he shall submit complete details of the process to be used by the NPC. If the butt splices are used the Contractor shall ensure that the splice meets the requirements specified herein by performing at least three splices which shall be submitted for tests to a testing laboratory that has been approved for such testing by the NPC. The cost of these shall be borne by the Contractor.

All reinforcement shall be furnished in the full lengths indicated on the Drawings. Splicing of bars, except where shown on the Drawings will not be permitted without the written approval of the NPC. When allowed, splices shall be staggered as far as possible and with a minimum separation of not less than 40 bar diameters. Not more than one-third of the bars may be spliced in the same cross section, except where shown on the Drawings.

Unless otherwise shown on the Drawings, bars shall be lapped a minimum distance of:

<u>Splice Type</u>	<u>Grade 40 Min.Lap</u>	<u>But Not Less Than</u>
Tension	24d	300mm
Compression	20d	300mm

Where d is the diameter of the bar. In lapped splices, the bars shall be placed in contact and wired together. Lapped splices will not be permitted at locations where the concrete section is insufficient to provide a minimum clear distance of one and one-third the maximum size of coarse aggregate between the splice and the nearest adjacent bar. Welding of reinforcing steel shall only be done if detailed on the Drawings or if authorized by the NPC in writing. Spiral



reinforcement shall be spliced by lapping at least one and half (1 1/2) turns or by butt-welding unless otherwise shown on the drawings.

**CW-7.4 Measurement and Payment**

The quantity to be paid for shall be the calculated theoretical number of kilograms of reinforcement steel bars as determined from the net length of the steel shown on the drawings, incorporated in the concrete and accepted.

The weight of deformed bars will be computed from the theoretical weight of the same nominal size as shown in the following tabulation:

<u>Designation</u>	<u>Size (mm)</u>	<u>Weight (kg/m)</u>
#2	6	0.222
#3	10	0.616
#4	12	0.888
#5	16	1.579
#6	20	2.468
#8	25	3.854
#9	28	4.833
#10	32	6.313
#11	36	7.991

Clips, ties, separators and other and related materials used for positioning and fastening the reinforcement in place as required by the NPC shall not be included in the weight-calculated payment under this item. If bars are substituted upon the Contractor's request and as a result, more steel is used than specified – only the amount specified shall be included.

When laps are made for splices, other than those shown on the drawings or required by the NPC and for the convenience of the Contractor, the extra steel shall not be measured nor paid for.

The accepted quantity shall be paid at the corresponding unit price for the item, Reinforcing Steel as shown in the Bill of Quantities which price and payment shall be made in full compensation for furnishing materials, labor, equipment and incidentals necessary to complete this item.

**CW-8.0 STRUCTURAL STEEL**

**CW-8.1 General**

This section covers the fabrication, erection, and shop painting of structural steel in accordance with the AISC "Manual of Steel Construction" referred to herein. In the AISC "Manual of Steel Construction" referred to herein, the Specification for Design, Fabrication, and Erection of Structural Steel for Buildings," and "Structural Joints using A325 or A490 Bolts" shall be considered a part thereto.



**CW-8.1.1 Submittals**

Shop Drawings of all structural steel in five (5) copies for approval prior to fabrication of structural steel with complete information necessary for the fabrication and erection of the component parts of the structure including the location, type and size of all bolts and welds, member sizes and lengths, camber & connector details, blocks, copes, and cuts. Include all welds by standard welding symbols.

Erection Plan consists of descriptive data to illustrate the structure steel erection procedure including the sequence of erection and temporary shoring and bracing, and written description of the detailed sequence of all welding, including each welding procedure to be performed.

Certificates of Conformance for the following:

- Bolts, Nuts and Washers
- Welding Electrodes and Rods
- Paint
- Steel
- Certified Test Reports

Chemical Analysis and Tensile Strength Test of structural steel in accordance to ASTM A53.

For high strength bolts and nuts, the Contractor shall also submit chemical analysis, including tensile strength and hardness tests as required by ASTM A325.

**CW-8.1.2 Delivery and Storage**

All materials shall be handled, shipped and stored in a manner that will prevent distortion or other damages. Materials shall be stored in a clean and properly drained location and out of contact with the ground. Damaged materials shall be replaced or, when permitted by NPC, may be repaired in an approved manner at no additional cost to NPC.

**CW-8.2 Materials**

All the materials shall be of the best quality of their kind, well graded and within the allowable distortions. They shall be free from flakes, corrosion, scale of fragments that could reduce the resistance and durability or injure the external appearance.

Except as modified herein, blast clean surfaces in accordance with SSPC SP6. Wash clean surfaces that become contaminated with rust, dirt, oil, grease or other contaminants with solvents until thoroughly clean. Ensure that steel to be embedded in concrete and surfaces when assembled, are free from rust, grease, dirt and other foreign matter.

**CW-8.2.1 Steel**

Materials shall conform to the respective specifications specified herein. Materials not otherwise specified herein shall conform to the AISC "Manual of Steel Construction".

Structural Steel:	ASTM A36
Steel Pipe:	ASTM A53, Type E or S, Grade B, ASTM A501
Steel W-Shape Piles (Soldier Piles):	ASTM A328

**CW-8.2.2 Bolts, Nuts and Washers:**

All bolts, nuts and washers shall be of hot-dip galvanized steel, in accordance with the following:

Bolts:	ASTM A307, Grade C or ASTM A36 for Anchor Bolts; ASTM A325 for Fastening Bolts
Nuts:	ASTM A563, Grade A, heavy hex style, except nuts less than 38mm may be provided in hex style
Washers:	ANSI B18.22.1, Type B

**CW-8.2.3 Accessories:**

Welding electrodes and steel structural members shall use:

Rods	E70XX electrodes
Non-shrink Grout	ASTM C827, non-metallic

**CW-8.3 Execution**

**CW-8.3.1 Fabrication**

Structural steel fabrication shall be in accordance with the applicable provisions of the Specification for the Design, Fabrication, and Erection of Structural Steel for Buildings as set forth in the AISC "Manual of Steel Construction".

**CW-8.3.2 Welding of Structural Steel Work:**

All welding works shall be as indicated in the drawings and shall conform to AWS D1.1 - 77 "Structural Welding Code". Unless specified on the drawings, fillet welds shall be a minimum of 5 mm (3/16") and welding electrodes shall be with a tensile strength of 485 MPa.

All welding works shall be executed by the AWS D1.1 qualified welders, welding operators and trackers, whose workmanship shall be subject to the approval of NPC.

### **CW-8.3.3 Shop Painting**

Except as otherwise specified, shop prime surfaces of all structural steel, except steel to be embedded in concrete or mortar. Surfaces to be welded shall not be coated within 12 mm from the specified top of the weld prior to welding. Insure that the surfaces are thoroughly dry and clean when the paint is applied. Do not paint on wet weather except under cover. Do not apply paint to steel, which is at a temperature that will cause blistering or porosity, or will otherwise be detrimental to the life of the paint. Apply paint with high quality workmanship, and coat all joints and crevices thoroughly. Prior to assembly, paint all surfaces that will be concealed or inaccessible after assembly.

Shop prime coat surfaces as soon as possible after cleaning. Apply one coat of inorganic zinc to a minimum dry film thickness of 100 microns.

- **Field painting:** When the erection work is complete, the heads of field bolts, all welds and any surface from which the shop coat of paint has become worn off or has otherwise become defective, shall be cleaned and thoroughly covered with one coat of shop coat paint. When the paint applied for touching up bolt heads and abraded surfaces has become thoroughly dry, apply two field coats of marine epoxy paint subject to the approval of NPC.

- **Marking:** Prior to erection, members shall be provided with a painted erection mark. In addition, connecting parts assembled in the shop for remaining holes in field connections shall be matched marked with scratch and notch marks. Do not locate erection markings on areas to be welded. Do not locate erection markings in areas that will decrease member strength or cause stress concentrations.

### **CW-8.3.4 Erection**

Except as modified herein, erect steel in accordance with the AISC "Manual of Steel Construction". Where parts cannot be assembled or fitted properly as a result of errors in fabrication or of deformation due to handling or transportation, report such condition immediately to the NPC's Representative and obtain approval there from for the methods of correction for straightening, including members of steel conforming to ASTM A514.

Drain Steel work properly; fill pockets in structures exposed to the weather with an approved waterproof material.

Provide safety belts and lines for workmen aloft on high structures unless safe working platforms or safety nets are provided.

When calibrated wrenches are used for tightening bolts, calibrate them at least one each working day using not less than three typical bolts of each diameter. Do not use impact torque wrenches to tighten anchor bolts set in concrete.



**Connections:** Connections shall be executed as shown on drawing. In case, connections are not detailed, it shall be designed in accordance with AISC "Manual of Steel Construction". Build connections into the existing work. Punch, sub-punch and ream, or drill bolt holes.

**Tolerances:** Structural steel shall be furnished and installed to the lines and levels as shown on the drawings.

Any structure that does not conform shall be repaired, removed and/or erected anew by the Contractor at no additional cost to NPC.

Tolerances on structural steel shall be in accordance with the "Code of Standard Practice" of the AISC "Manual of Steel Construction".

#### **CW-8.3.5 Tests and Inspections**

**Visual Inspection of Welding:** After the welding is completed, hand or power wires brush welds, thoroughly clean them before the inspector makes the check inspection. Inspect welds with magnifiers under strong, adequate light for surface cracking, porosity, and slag inclusions; excessive roughness; unfilled craters; gas pockets; undercuts; overlaps; size and insufficient throat and concavity. Inspect the preparation of groove welds for adequate throat opening and for snug positioning of backup bars.

**Non-Destructive Testing<sup>1</sup>:** In accordance with AWS D1.1 Twenty-five percent (25%) of the total number of joints, as selected by the NPC, shall be tested. If more than 20 percent of welds contain defects identified by testing, then all welds shall be tested by radiographic or ultrasonic testing, and to be approved by the NPC. When all welds made are required to be tested, magnetic particle testing shall be used only in areas inaccessible to either radiographic or ultrasonic testing. Retest defective areas after repair.

#### **CW-8.4 Measurement and Payment**

Measurement for payment for structural steel shall be based on the total kilogram of structural steel placed and accepted.

Payment will be made at the contract unit price for the item Structural Steel in the Bill of Quantities, which payment shall constitute full compensation for furnishing all labor, materials and equipment necessary to complete the item.

#### **CW-9.0 DRAINAGE SYSTEM AND APPURTENANT STRUCTURES**

##### **CW-9.1 Scope**

In accordance with the specifications contained herein, the Contractor shall furnish all materials, labor, equipment and tools, perform all required excavation and backfill, install all pipes and construct canals and ditches, as the case may be, where indicated on the drawings or where directed

<sup>1</sup> Not applicable on non-critical structures/joints and as directed/required by NPC Design Engineer.

conforming with the lines and grades as established in the field by the NPC. The Contractor shall also construct or install, where required, appurtenant structures like street inlet, street inlet-catch basin combination, manhole, catch basin for downspouts, drainage outlets, etc. as well as joints and connections as may be required to complete the system.

## **CW-9.2 Materials**

### **CW-9.2.1 Non-Reinforced Concrete Drainage Pipes**

Non-reinforced concrete drainage pipes shall meet the requirements of ASTM C14-68.

One pipe length shall be taken at random representing a group of fifty (50) pipes or fraction thereof of the same size and shall be submitted for test. Any group represented by corresponding test specimens that do not meet the strength and other test requirements shall not be used in the work.

### **CW-9.2.2 Reinforced Concrete Drainage Pipes**

Reinforced concrete drainage pipes shall meet the design and test requirements for Class II Reinforced Concrete Pipes in accordance with ASTM C76-68 and ASTM C497-67.

One (1) pipe length shall be taken at random representing a group of fifty (50) pipes or fraction thereof of the same size and shall be submitted for test. Any group represented by corresponding test specimens that do not meet the strength and other requirements shall not be used in the work.

### **CW-9.2.3 PVC Pipes**

Polyvinyl Chloride (PVC) Pipes shall be unplasticized conforming to ISO4435 or equivalent. Details/scheme of perforation shall be as indicated in the bid drawing or as directed by NPC.

### **CW-9.2.4 Concrete Covered Rectangular Ditch**

Cement, reinforcing steel, aggregate and water to be used for the construction of concrete covered rectangular ditch and open rectangular canal shall conform to the requirements set forth in Section CW-6.0 – Concrete. Foundation base material for concrete canal shall be sand and gravel as described in Section CW-5.0.

### **CW-9.2.5 Bedding Material**

#### **A. For Stable Soil and Rock Foundation**

Bedding material for sewerage and drainage pipes in stable soil and rock foundation, as determined by NPC, shall consist of sand or natural sandy soil in which all the materials passes a 9.5 mm (3/8") sieve but not more than 10% passes a 0.074 mm (No. 200) sieve.

**B. For Unstable Foundation**

Bedding for sewerage and drainage pipes in soft and unstable foundation as determined by the NPC, shall consist of 13.79MPa concrete cradle in conformity with the dimensions shown on the drawings, or as determined by the NPC.

**C. Foundation under Roadways and Parking Areas**

Bedding for sewerage and drainage pipes crossing under roadways and parking areas with pipe cover (excluding concrete or asphalt pavement) of 60.9 cm (2 ft.) or less shall consist of 13.79MPa concrete cradle in conformity with the dimensions shown on the drawings, or as determined by the NPC.

**CW-9.3 Construction****CW-9.3.1 Trench Excavation and Backfill**

Trench excavation and backfill work shall be done in accordance with the pertinent provisions of Section CW-5.0.

**CW-9.3.2 Concrete Canal**

Concrete canal, open or covered, shall be constructed in accordance with the lines and grades shown on the drawings. Class of concrete shall be as indicated on the drawings or directed by the NPC.

**CW-9.3.3 Appurtenant Structures**

Appurtenant structures like street inlet, street inlet-catch basin combination, manhole, catch basin for downspouts, catch basin for intersecting perforated PVC pipes, septic tank, drainage outlets, etc. shall be constructed at locations indicated on the plans or at the other convenient locations designated by the NPC. All appurtenant structures shall be of 17.30 MPa concrete unless otherwise shown on the drawings.

**CW-9.4 Pipe Installation****CW-9.4.1 General**

Before any drain pipe is installed, the sand or concrete bedding shall have been prepared and approved in accordance with the grade, shape, and dimensions shown on the drawings, or as directed by the NPC. No pipe over 45.7 cm (18") in diameter shall be laid on concrete bedding until seven (7) days have been elapsed after placing the concrete bedding. Pipes under 45.7 cm (18") in diameter may be laid after five (5) days elapsed after placing the concrete bedding.

All drain pipes shall be laid carefully, hubs upgraded, ends fully and closely jointed, and true to the lines and grades given. Succeeding pipe shall be jointed to the previously laid pipe, correct in alignment and grade. Any pipe, which has

been damaged during installation or before acceptance of the work, shall be replaced and laid by the Contractor at his expense.

#### **CW-9.4.2 Non-Reinforced and Reinforced Concrete Drainage Pipes**

Whenever possible, concrete pipes shall be handled and installed with the aid of mechanical equipment and not just rolled or pushed into the trench from the bank. For small pipes, rope slings may be placed at both ends of the pipes and the rope slowly paved out until the pipe rests on the trench bed. proper and careful handling and laying should be observed at all times to prevent unnecessary structural damage to the pipe, especially at the pipe ends.

For pipes on sand bedding, before joining the next pipe length to the last pipe already laid, the bottom of the trench shall be excavated to the shape, size and location of the collar below the joint. The next pipe section shall then be securely attached to the previously laid pipe seeing to it the correct alignment and grade is always attained. Same procedures shall be observed for the remaining pipes.

All pipe joints shall be filled with stiff mortar composed of one (1) part cement and two (2) parts clean sand and enough water. The inside part of the joint shall be plastered properly to bring the inside surfaces of jointed pipe ends flush even. Sufficient mortar shall be placed on the outside surface of joint to form a bead around the joint. Plastering work shall be as directed and approved by the NPC. After initial set, the mortar on the outside surface shall be protected from air and sunlight with a cover thoroughly wetted earth or burlap. Curing of the joint shall be done for a period of at least seven (7) days within which no backfill shall be placed on the installed pipeline.

#### **CW-9.5 Measurement and Payment**

##### **CW-9.5.1 Concrete Rectangular Ditch**

Measurement for payment for rectangular ditch and other channels will be based on the number of linear meters of canal constructed and accepted.

Payment will be made at the corresponding contract unit price per linear meter of the pertinent items shown in the Bill of Quantities. Payment shall constitute full compensation for furnishing all labor, materials, equipment and tools necessary for the construction of the concrete canal including attendant excavation and backfill.

##### **CW-9.5.2 Concrete Drainage Pipes and PVC Pipes**

Non-reinforced and reinforced concrete drain pipes, and PVC pipes in place and accepted will be measured by the linear meter along the centerline of the pipeline.

The quantities measured as provided above, completely installed and accepted, will be paid at the contract unit price for each size and kind of pipe shown in the Bill of Quantities. Payment shall constitute full compensation for furnishing all labor, material, equipment and tools for fabricating, hauling,

installing and jointing of pipes. Payment shall also include the cost of attendant excavation, bedding and backfilling.

#### **CW-9.5.3 Appurtenant Structures**

Measurement for payment of appurtenant structures like street inlet, street inlet-catch basin combination, manhole, catch basin for downspouts, septic tank, drainage outlets, etc. will be based on the number of structures constructed/installed and accepted.

The Contractor will be paid at the contract unit price for the pertinent item for each appurtenant structure shown in the Bill of Quantities. Such payment shall cover all costs for furnishing all equipment, labor, materials and tools necessary to complete the construction of the aforementioned appurtenant structures. Payment also includes the cost of attendant excavation and backfill, furnishing, scheduling, cutting, bending and placing of reinforcing steel.

#### **CW-9.5.4 Bedding**

Measurement for payment for sand or natural sandy soil bedding and concrete cradle will be based on the number of cubic meters of materials placed and accepted.

Payment will be made at the corresponding contract unit price for the item. Sand Bedding for Pipes, and item, Concrete Cradle for Pipes, in the Bill of Quantities, which payment shall constitute full compensation for furnishing all labor, materials, equipment and tools necessary to complete the items.

Braces such as flat and x-braces, shall be attached where required. The braces shall be attached by the Supplier in accordance with the drawings. All nuts shall be tightened adequately.

Payment will be made at the contract unit price for the items, Steel Pole and; Steel Cross-arms and Braces in the Bill of Quantities, which payment shall constitute full compensation for furnishing of all materials, labor and hardwares and accessories necessary to complete the items.

#### **CW-10.0 GROUTING**

##### **CW-10.1 Scope**

This specification covers the requirements for the furnishing and installation of 2 component concrete epoxy grout unless shown otherwise on the design drawings.

##### **CW-10.2 Physical Properties**

The cured product shall have the following properties:  
Tensile Strength = 27.65 MPa (4000 psi) min.

Compressive Strength = 63.60 MPa (9200 psi)

**CW-10.3 Submittals**

The Contractor shall submit copies of brochures/specifications for NPC's approval.

**CW-10.4 Measurement and Payment**

Measurement for payment for Grouting will be based on the number of liters placed and accepted by NPC. Payment shall be made at the corresponding contract price for Grouting shown in the Bill of Quantities. Payment shall include all costs including supply of labor and materials and other incidentals necessary for the completion of the work.

**CW-11.0 HIGH DENSITY POLYTHYLENE LINER**

**CW-11.1 Scope**

This specification covers the requirements for the furnishing and installation of High Density Polyethylene Liner unless shown otherwise on the design drawings.

**CW-11.2 Physical Properties**

The High Density Polyethylene Liner shall be made from virgin homopolymer (petroleum product) with carbon black for UV protection and it should be resistant to most acids, chemicals and compounds.

**CW-11.3 Submittals**

The Contractor shall submit copies of brochures/specifications for NPC's approval.

**CW-11.4 Measurement and Payment**

Measurement for payment for High Density Polyethylene Liner will be based on the number of square meters placed and accepted by NPC. Payment shall be made at the corresponding contract price for High Density Polyethylene Liner shown in the Bill of Quantities. Payment shall include all costs including supply of labor and materials and other incidentals necessary for the completion of the work.

**CW-12.0 DRAIN PIPES**

**CW-12.1 Scope**

This specification covers the requirements for the furnishing and installation of PVC Drain Pipes unless shown otherwise on the design drawings.

**CW-12.2 Physical Properties**

The drain pipes shall be Polyvinyl Chloride and shall be unplasticized conforming to ISO 4435 or equivalent.

**CW-12.3 Submittals**

The Contractor shall submit copies of brochures/specifications for NPC's approval.

**CW-12.4 Measurement and Payment**

Measurement for payment for PVC Drain Pipes will be based on the number of linear meters placed and accepted by NPC. Payment shall be made at the corresponding contract price for PVC Drain Pipes shown in the Bill of Quantities. Payment shall include all costs including supply of labor and materials and other incidentals necessary for the completion of the work.

**CW-13.0 PVC WATERSTOP****CW-13.1 Scope**

This specification covers the requirements for the furnishing and installation of PVC Drain Pipes unless shown otherwise on the design drawings.

**CW-13.2 Physical Properties**

The PVC Waterstop shall have the following properties:  
Tensile Strength = 13.82 MPa (2000 psi) min.  
Tear Resistance = 115.87 N/mm (300 lb/in)

**CW-13.3 Submittals**

The Contractor shall submit copies of brochures/specifications for NPC's approval.

**CW-13.4 Measurement and Payment**

Measurement for payment for uPVC Drain Pipes will be based on the number of linear meters placed and accepted by NPC. Payment shall be made at the corresponding contract price for PVC Drain Pipes shown in the Bill of Quantities. Payment shall include all costs including supply of labor and materials and other incidentals necessary for the completion of the work.

## **PART I**

# **TECHNICAL SPECIFICATIONS**

## **MW - MECHANICAL WORKS**





**PART I - TECHNICAL SPECIFICATIONS**

**MW – MECHANICAL WORKS**

**TABLE OF CONTENTS**

<u>CLAUSE NO.</u>	<u>TITLE</u>	<u>PAGE NO.</u>
MW-1.0	GENERAL .....	1
MW-2.0	SCOPE OF WORK.....	1
MW- 3.0	FUEL OIL STORAGE TANK (FOST) .....	2
MW-3.1	General.....	2
MW-3.2	Scope of Work .....	3
MW-3.3	Materials .....	4
MW-3.4	Design and Construction.....	4
MW-3.4.1	Shell .....	5
MW-3.4.2	Bottom .....	5
MW-3.4.3	Roof .....	6
MW-3.4.4	Shell Attachments and Tank Appurtenances .....	6
MW-3.4.4.1	Vertical Caged Ladders and Hand railings .....	6
MW-3.4.4.2	Manholes and Nozzles.....	7
MW-3.4.4.3	Grounding Pads & Rod .....	7
MW-3.4.4.4	Nameplate .....	7
MW-3.4.4.5	Holding Down Bolts .....	8
MW-3.4.4.6	Piping, Valves and Fittings.....	8
MW-3.4.4.7	Gauges and Instrumentation.....	8
MW-3.4.4.8	Sounding Tape (10 m long).....	9
MW-3.5	Erection .....	9
MW-3.6	Test and Inspection .....	10
MW-3.6.1	Weld Inspection .....	10
MW-3.6.2	Methods of Inspecting Vertical and Horizontal Joints .....	11
MW-3.6.3	Tank Testing .....	11
MW-3.6.4	Repairs .....	12
MW-3.7	Tank Calibration.....	13
MW-3.8	Painting Requirements.....	13
MW-3.8.1	General .....	13
MW-3.8.2	Surface Preparation.....	13
MW-3.8.3	Painting Application .....	13
MW-4.0	FUEL OIL TRANSFER PUMP .....	14
MW-4.1	General.....	14
MW-4.2	Scope of Works .....	14
MW-4.3	Design and Construction.....	16
MW-4.4	Spare Parts.....	17
MW-4.5	Pump House.....	17
MW-4.6	Submittal.....	18
MW-4.7	Pump Testing .....	18
MW-4.8	Painting .....	18
MW-5.0	FUEL OIL TRANSFER AND WASTE OIL/WATER PIPING SYSTEM .....	19
MW-5.1	Scope of Works .....	19

MW-5.2	Piping .....	19
MW-5.3	Valves.....	20
MW-5.4	Strainers .....	20
MW-5.5	Pressure Gauges.....	20
MW-5.6	Flowmeters .....	20
MW-5.7	Testing.....	21
MW-5.8	Painting .....	21
<b>MW-6.0</b>	<b>FIRE EXTINGUISHER SYSTEM .....</b>	<b>22</b>
MW-6.1	General.....	22
MW-6.2	Portable Fire Extinguishers.....	22
MW-6.2.1	Scope of work .....	22
MW-6.2.2	Technical Requirements .....	22
MW-6.2.3	Submittals.....	23
<b>MW-7.0</b>	<b>EQUIPMENT MARKING AND LABELING .....</b>	<b>23</b>
<b>MW-8.0</b>	<b>GUARANTEE.....</b>	<b>24</b>
<b>MW-9.0</b>	<b>MEASUREMENT OF PAYMENT .....</b>	<b>24</b>

## PART I - TECHNICAL SPECIFICATIONS

### MW - MECHANICAL WORKS

#### MW-1.0 GENERAL

The work to be done under this specification shall include the furnishing of all labor, materials, equipment, tools and other incidentals required for all mechanical and associated works specified herein and shown on the accompanying drawings for the **Supply, Delivery, Installation And Test of 1 x 35 kL and 2 x 60 kL FOST for Patnanungan DPP, Palanan DPP, and Jomalig DPP including Construction of Associated Facilities under Package 1.**

All equipment and materials to be supplied by the Contractor shall be new and unused, of current manufacture, and of the highest Grade and the best of their respective kinds, and free from defects and imperfections. They shall be suitable for their intended purpose and shall comply with all applicable regulations, quality, and dimension standards.

The work shall be performed and completed in a high quality workmanship in accordance with all applicable codes, standards and generally accepted modern practice in the Supply, Fabrication, Installation and Test of the Fuel Oil Storage Tank, Auxiliary Equipment/Accessories and Associated Facilities. To have quality workmanship, only technicians skilled in their respective trades shall be employed.

The Contractor shall strictly observe the requirements specified in this Specific Technical Specification (Mechanical Works) in conjunction with the General Technical Specification (General Works), if applicable. The Specific Technical Specification shall take precedence over the General Technical Specifications in case of any inconsistency.

#### MW-2.0 SCOPE OF WORK

In accordance with the specifications contained in this section and as shown on the drawings, the scope of this Contract covers the supply, delivery, fabrication, installation/erection and test of all mechanical equipment and materials as required for the various facilities including all other works and services as required to complete the project, but not limited to the following:

- a) One (1) set of 35 m<sup>3</sup> Diesel Fuel Oil Storage Tanks complete with associated valves and piping works, level gauge, vertical caged ladder and other tank appurtenances/accessories including tank calibration, testing (hydrostatic and liquid penetrant), sandblasting and painting;
- b) Two (2) sets of 60 m<sup>3</sup> Diesel Fuel Oil Storage Tanks complete with associated valves and piping works, level gauge, vertical caged ladder and other tank appurtenances/accessories including tank calibration, testing (hydrostatic and liquid penetrant), sandblasting and painting;

- c) One (1) set of Fuel Oil Transfer Pump with capacity not less than 10m<sup>3</sup>/hr at a discharge head of 30m complete with associated valves and piping works, controls and instrumentation and other accessories including spare parts for one (1) year operation (for each plant);
- d) One (1) lot of piping materials complete with valves, fittings, supports and accessories, interconnection works with the common piping and existing piping systems (fuel oil storage tank & fuel oil day tanks' supply/filling), oil-waste piping to existing/new oil-water separator and associated structural steel supports, including any required excavation and backfilling works; coating and painting (for each plant);
- e) Supply and installation of three (3) sets of Foam (AFFF) wheeled type fire extinguisher, UL/FM approved, complete with self-contained cylinder mounted on a frame with handle, floor stand and steel wheels, 125 L (33 gallons) capacity complete with associated valves, dial gauge indicator, nitrogen expellant tank for unit pressurization, appropriate size of discharge hose of 15 m long fitted with couplings and foam nozzle assembly;
- f) Supply, delivery, installation of three (3) units of UL/FM approved Fire Fighting Equipment (Portable Fire Extinguisher); and
- g) All other works and services required to complete the project.

**MW- 3.0 FUEL OIL STORAGE TANK (FOST)**

**MW-3.1 General**

The design, fabrication, erection and testing of FOST shall conform to the requirements specified in this general specifications, applicable codes & standards and as shown on the accompanying drawings.

Upon completion of erection and testing, FOST shall be shot blasted internally and externally and painted with approved quality paint to withstand the anticipated service conditions.

FOST shall be provided with necessary nozzles for connections to all pipeworks as shown on the drawings which include tapping points for instrumentation, manholes, vents, drains and other appurtenances such as stairways, caged ladder, hand railings, and etc.

The tank shall be provided with two hinged and jointed manhole doors (@ shell and roof) secured by bolts and winged nuts.

Prior to the purchase of materials, fabrication and erection/installation of the FOST, the Contractor shall submit for approval by NPC, brochures for tank materials, associated valves and piping materials, painting specifications, test procedures including necessary erection/installation details as required.

**MW-3.2 Scope of Work**

The work shall comprise all labor, tools, supply of appurtenant materials and other incidental for all works enumerated hereunder in accordance with the Specifications contained herein and as shown in the drawings or otherwise directed by the NPC.

The scope of the work shall consist of but not limited to the following:

**a. Patnanungan DPP**

- a.1 Design, fabrication, delivery, installation/erection and testing of one (1) unit of FOST with a nominal capacity of 35 cu. m. with a diameter of 3.0 m and height of 5.4 m;
- a.2 Fabrication/installation of vertical caged ladder, railings, manholes, roof vents, intake and discharge nozzles, air-foam chamber nozzles, drain and overflow nozzles, sounding gauge hatches, heat detector nozzles, level gauges and switches and other accessories shown on the bid drawings or specified herein;
- a.3 Three (3) units of 65 mm Ø gate valves for FOST inlet, outlet and spare nozzle;
- a.4 One (1) unit of 50 mm Ø gate valve for drain line;
- a.5 One (1) unit of 150 mm Ø butterfly valve for tank farm drain outlet;
- a.6 One (1) lot of sandblasting, painting and testing; and
- a.7 One (1) unit of 10 m long fuel oil sounding tape.
- a.8 Two (2) units of 50 mm Ø check valves

**b. Palanan DPP and Jomalig DPP**

- b.1 Design, fabrication, delivery, installation/erection and testing of two (2) units of FOST with a nominal capacity of 60 cu. m. with a diameter of 3.6 m and height of 6.1 m;
- b.2 Fabrication/installation of vertical caged ladder, railings, manholes, roof vents, intake and discharge nozzles, air-foam chamber nozzles, drain and overflow nozzles, sounding gauge hatches, heat detector nozzles, level gauges and switches and other accessories shown on the bid drawings or specified herein;
- b.3 Six (6) units of 65 mm Ø gate valves for FOST inlet, outlet and spare nozzle;
- b.4 Two (2) units of 50 mm Ø gate valve for drain line;
- b.5 Two (2) units of 150 mm Ø butterfly valve for tank farm drain outlet;
- b.6 One (1) lot of sandblasting, painting and testing (for each plant; and
- b.7 Two (2) units of 10 m long fuel oil sounding tape.
- b.8 Five (5) units of 65mm Ø check valves
- b.9 Twelve (12) units of 25mm Ø gate valves

**MW-3.3 Materials**

All materials to be used for the FOST shall be new and unused and of the best grade and quality for the purpose. All manufactured items shall be standard commercial products of reputable manufacturers and in case where the materials shown in the drawing are not covered by the standards or specifications, the Supplier/Contractor shall furnish high quality materials which are acceptable to the applicable specifications and provisions of ASTM A-36 and AISC Standard Specifications or equivalent approved by NPC.

All materials used for pipes and fittings shall be carbon steel, Schedule 40, seamless, conforming to ASTM A53 Grade B, unless otherwise approved. Valves shall be cast or forged carbon steel body materials, flanged ends, with rising stem and generally be of gate valve type for size 65 mm in diameter, unless otherwise specified. Valves 50 mm  $\varnothing$  and below shall be of all bronze material, unless otherwise specified.

Plates shall be shaped at shop and edges be sheared, machined or chipped to suit the curvature of the tank and shall be marked before shipment to site.

Dimensions of tank plates shown on the accompanying drawings are in equivalent SI (metric) units converted from a standard size plates with US customary units. Plates of standard size with SI units may be used by the Supplier/Contractor subject to submission of relevant assembly/construction drawings for NPC's review and approval.

Certified mill test reports, covering all steel plate and structural shapes to be used in the work and as required by the governing codes and standards shall be furnished by the Supplier/Contractor for NPC's record. Copies of each mill test report shall be submitted to the NPC prior to fabrication of materials covered.

**MW-3.4 Design and Construction**

The FOST shall be of all welded construction designed, fabricated, constructed and erected in accordance with the requirement of API Standard 650 including Appendix E and shall be supplied complete with manholes, nozzles, level gauge, spiral stairways, caged ladder, railings, associated valves and piping works as shown on the drawings.

The FOST shall be vertical, cylindrical and with self-supporting conical roof.

The FOST shall be designed for erection on a concrete ring wall type foundation and shall conform to API standard requirements. The foundations shall be in accordance with the requirements shown on the relevant Civil Work drawings.

The fuel storage tank shall be designed and constructed with the following criteria:

**MW-3.4.1 Shell**

The shell plates of the tanks shall be constructed of not less than the thickness (corrosion allowance included) specified and shown on the drawings conforming to ASTM A 36 material.

The shell plates of the tanks shall be designed to have all courses truly vertical.

Shell vertical joints shall be by butt-weld with complete penetration and fusion as attained by double welding or by other means which obtain the same quality of deposited weld metal on the inside and the outside weld surface. Vertical joints in adjacent shell courses shall not be in alignment, but shall be offset from each other a minimum distance of five (5) times the thickness of the thicker course at the offset point.

Shell horizontal joints shall be by butt weld with complete penetration and fusion. Abutting shell plates shall have a common vertical centerline.

Top angles of A 36 material shall be attached to the shell either by butt joint which shall be of complete penetration and fusion or an alternative joint as shown on the drawing. Top angle size shall not be less than 75mm x 75mm x 6mm and the outstanding leg extends outside the tank.

Shell plates shall be of standard size conforming to 1,200mm (4ft.) wide, 2,440mm (8ft.) long and edges shall be properly squared and/or prepared for butt welding. Minimum thickness shall be 5mm or as shown on drawings.

Shell plates of standard size conforming to 1,830mm (6ft.) wide, 6,100mm (2ft.) long may be used if transportation to the specified plant site is accessible through land transportation direct from the source. Accordingly, detailed drawings showing arrangements of plates for shell, roof and bottom shall be submitted by the Contractor for NPC's review and approval.

**MW-3.4.2 Bottom**

Bottom plates shall have a minimum thickness of 8.0mm (5/16") (allowance for corrosion included) or as shown on the drawings with standard plate size similar the shell plates and conforming to A36 material. The plates shall be joined by lap welding, arranged as shown in the bid drawings. Three (3) plate laps in tank bottoms shall not be closer than 300mm (12") from each other and also from the tank shell. The bottom plates under the bottom shell ring shall have the outer ends of the joints fitted and lap-welded to form a smooth bearing for the shell plates.

Where butt-welded bottom plates are employed, the edges shall be prepared with either square or V-grooves. The butt welds shall be made by applying a backing strip 3mm (1/8") thick or heavier by tack welding to the underside of the plate. The bottom plates shall have a minimum slope of 1:100mm.

The attachment between the bottom edge of the lowest course shell plate and the bottom plates shall be a continuous fillet weld laid on each side of the shell plate.

#### **MW-3.4.3 Roof**

The roof of the 35 m<sup>3</sup> of the tanks shall be of self-supported-cone type provided with rafters. The roof and its supports shall be constructed in accordance with API 650, Standard for Construction of Welded Steel Tank.

The slope self-supporting cone type roof shall be 15 degrees or as shown on the drawings. All roofs and supporting structures shall be designed to support dead load, plus a uniform live load of not less than 1.0 kPa (20 lbs/sq.ft.) of projected area. Roof plates shall have a minimum nominal thickness of 5mm (3/16") and its material shall be ASTM A36.

The roof plates shall be welded to each other on top side with a continuous full-fillet weld on all seams and shall not be attached to the supporting members. The roof plate circumference shall be attached to the top angle (not less than 75mm x 75mm x 6mm) of the tank with a continuous fillet weld on the top side only. Rafters supported on shell by means of rafter lugs are welded to the tank shell and connected to the collar plate or center column if required, as shown on the drawings. Where other construction is employed, detailed drawings shall be submitted by the Contractor for NPC's review and approval.

#### **MW-3.4.4 Shell Attachments and Tank Appurtenances**

The tanks shall be provided with the following appurtenances generally arranged in accordance with the bid drawings:

- a) Vertical Caged Ladder and Hand railings
- b) Roof manhole
- c) Shell manhole
- d) Shell outlet nozzle
- e) Shell inlet nozzle with riser pipe
- f) Water draw off sump nozzle & piping
- g) Roof vent
- h) Overflow nozzle & piping
- i) Sounding gauge hatch
- j) Level gauge nozzles
- k) Heat detector nozzle
- l) Air-foam nozzle with riser pipe
- m) Grounding pads
- n) Nameplate
- o) Sounding Tape

##### **MW-3.4.4.1 Vertical Caged Ladders and Hand railings**

The tank shall be provided with vertical caged ladders. Caged ladder shall be 450 mm wide with 25 mm round bar ladder rungs spaced at 300 mm center to center. Cage starts at 2000 mm from the bottom of ladder and extends 1000 mm over the top of the ladder or at the same level of the tanks hand railings. Cage horizontal bars and vertical supports shall



be 50 mm x 6 mm. Center of rung to cage shall be 675 mm and radius of loop shall be at least 375 mm.

All parts shall be made of A36 except otherwise specified and hot dipped galvanized.

#### **MW-3.4.4.2 Manholes and Nozzles**

Manholes and nozzles shall be provided and constructed in accordance with the bid drawings or with API 650. Reinforcing plates for these openings shall be made of one piece only. The minimum cross-section area of the reinforcement shall not be less than the product of the vertical diameter of the hole in the shell and gross plate thickness used. The necks, reinforcing plates and shell-plate openings which have either sheared or oxygen-cut surfaces shall have such surfaces uniformed and smoothen, with corners rounded, except where such surfaces are fully covered by attachment welds.

The tank atmospheric vent shall be fitted with a stainless filter of a replaceable type. Vent shall conform to the requirements of API Standard 2000.

Manholes and nozzles attached or fitted on the tank shall be of carbon steel, Schedule 40, seamless pipe conforming to ASTM A53 Grade B. Manholes may be fabricated using carbon steel plate or approved material subject however to radiographic test (RT) after fabrication.

Manholes on tank shall be furnished with hinged cover as shown on the drawings. Design of hinged components other than those shown on the drawings may be used provided that detailed drawings shall be submitted by the Contractor for NPC's review and approval.

#### **MW-3.4.4.3 Grounding Pads & Rod**

Each tank shall be provided with at least two (2) grounding pads equally spaced around the exterior of the tank for grounding protection. Grounding pads shall be type 304 stainless steel or approved equivalent and shall be welded to the tank. Pads shall be at least 65mm by 75mm by 6mm thick and shall be drilled and tapped to the full thickness of the pad for hex head cap screws. Screw hole spacing and location shall match that of NEMA Standard hole terminals or as shown on the drawings.

Grounding rods to be used shall be of copper with minimum size of 20mm  $\varnothing$  and 3m long with connecting copper wire between grounding pad and rod or as required.

#### **MW-3.4.4.4 Nameplate**

Nameplate shall be provided and securely fixed to the tank at location which are readily visible. The main inscriptions on the nameplate shall include Tank Tag Number or SPIN (FO01TNK), Manufacturer/fabricator, Design Code, Nominal Capacity, Nominal Diameter, Nominal Height, Date of Manufacture and etc.

In addition to the nameplate, the lettering "NPC" and the NPC Logo shall be painted on one side of the outside wall surfaces of the fuel oil storage tank facing the national road or main highway. The exact location of which shall be as directed by NPC. Each letter shall have at least a height of 0.6 m and approximately 0.45 m. width, or as otherwise directed by NPC. The color of the letters shall be luminous black. The color of NPC logo shall conform to its standard color.

#### **MW-3.4.4.5 Holding Down Bolts**

Holding down bolts shall be provided to protect the tank from skidding or overturning due to wind load or earthquake load. Number and size of bolts shall be provided as shown on drawings and equally spaced high strength bolts conforming to ASTM A 307 or approved equivalent.

#### **MW-3.4.4.6 Piping, Valves and Fittings**

Interconnecting piping to be installed shall be as shown on the drawings. Piping and fittings shall be of carbon steel, Schedule 40, seamless pipe conforming to ASTM A53 Grade B.

Inlet, outlet, water draw-off nozzles including spare nozzle shall be supplied with valves of sizes preferably similar to the nozzles unless otherwise specified or shown on the drawings. Air foam and heat detector nozzles for future use shall be provided with blind flanges or plug as applicable. Valves 65 mm and above shall be of rising stem, cast and forged carbon steel body, and with flange ends. Valves 50 mm and under shall be of bronze material, rising stem and with flanged or screwed ends. Gate valves shall generally be used, except for 150 mm Ø valve installed on waste oil drain to oil water separator, which is butterfly valve.

All valves that are directly connected to the tank nozzles shall have flanged ends.

#### **MW-3.4.4.7 Gauges and Instrumentation**

The tank shall be outfitted with all the proper instrumentation and/or gauge necessary for the accurate monitoring and control of the Diesel Fuel Oil.

The tank shall be provided with a ground receding level gauge. The level gauge shall be completed with welded hollow shell float, guide wires, tape, sheave elbows, tape conduit (pipe), support brackets, gauge head and level switches. The level gauge shall be constructed of the following materials:

- |    |                         |   |                    |
|----|-------------------------|---|--------------------|
| a) | Gauge head              | - | Aluminum           |
| b) | Sheave elbows           | - | Aluminum           |
| c) | Sheaves                 | - | Stainless steel    |
| d) | Float                   | - | Stainless steel    |
| e) | Guide & gauge wires     | - | Stainless steel    |
| f) | Guide wires anchor      | - | Stainless steel    |
| g) | Support brackets        | - | Carbon steel       |
| h) | Gauge wire conduit pipe | - | ASTM 53 galvanized |

The level gauge shall be so located that tank liquid level can be accurately indicated to a height equal to the straight side height of the tank.

All connection lugs or openings in the tank required for gauge equipment installation shall be furnished.

A calibration scale shall be printed on the tank and shall be large enough so it can easily be visible preferably from the powerhouse.

Wires and cables to be used and installed aboveground shall be enclosed in a rigid steel conduit (galvanized) except those laid on cable trays. Cables installed underground shall likewise be enclosed and pipe sleeve are coated with bituminous paint.

#### **MW-3.4.4.8 Sounding Tape (10 m long)**

The Contractor shall include the supply of three (3) sets of 10-meter long sounding Tape. Tape body/frame shall be of aluminum alloy with stainless steel tape and brass dropper.

#### **MW-3.5 Erection**

The Contractor shall furnish all labor, tools, welding equipment and cables, falsework, scaffolding and other equipment necessary for the erection of the tank complete and ready for use. Lifting lugs attached to the tank for erection purposes shall be removed by the Contractor and any noticeable projection of weld metal shall be chipped-off.

Shell plates shall be shaped to suit the curvature of the tank at the shop prior to shipment to the project site.

Tank shell seams shall be so positioned that they do not pass through vessel connections. Inside seam shall be ground smooth for application of the internal's protective coating.

The tank and their structural's shall be welded by shielded metal-arc, the gas metal-arc, the flux-cored-arc, the electroslag or the electrogas process using suitable equipment. Welding may be performed manually, automatically or semi-automatically according to procedures described in ASME Section IX. Welding shall be performed in a manner to ensure complete fusion with the base metal. No welding of any kind shall be performed when the surfaces to be welded are wet, dirty nor during high winds unless the welder and the work are properly shielded. Each layer of weld metal or multi-layer shall be cleaned of slag and other deposits before applying the next layer.

The edges of all welds shall merge with the surface of the plate without a sharp angle. The maximum acceptable undercut shall be 0.4mm (1/64") of the base metal for vertical butt joints and 0.79mm (1/32") in depth for horizontal butt joints.

Tack weld, a weld made to hold parts of a weldment in proper alignment until final welds are made, shall not be considered as having any strength value in the finished structure.

The minimum size of fillet weld shall be as follows: plates 5mm (3/16") thick, not less than one-third the thickness of the thinner plate at the joint, with minimum of 5mm (3/16"). Single welded lap joints are permissible only on bottom plates and roof plates. Lap-welded joints, as tack-welded, shall be lapped not less than five (5) times the nominal thickness of the thinner joints, the lap need not exceed 50.8mm (2") and 25.4mm (1") for single welded lap joints. The reinforcement thickness of the welds on all butt joints on each side of the plate shall not exceed 2.4mm (3/32") and 3.2mm (1/8") for vertical and horizontal joints respectively. The reinforcement need not be removed except that it exceeds the maximum acceptable thickness. During the welding operation, plates shall be held close contact at all lap joints. Tack welds used in the assembly of vertical joints of the shell shall be removed when such joints are, welded manually. Tack welds, whether removed or left in place, shall be made using a fillet weld or butt weld procedure. Tack welds to be left in place shall be made by qualified welder and shall be examined visually for defects. Defective tack shall be removed.

Misalignment in completed vertical joints shall not exceed 10% of the plate thickness or 1.6mm (1/16"), whichever is larger. The upper plates in completed horizontal butt joints shall not project beyond the face of the lower plate at any point by more than 20% of the upper plate thickness, with a maximum projection of 3.2mm (1/8"), except that a projection of 1.6mm (1/16") is acceptable for upper plates less than 7.9mm (5/16") thick.

### **MW-3.6 Test and Inspection**

Test and inspection of all materials and equipment shall be performed in accordance with the requirements of all applicable codes and standards, unless otherwise stated in this specification.

The Contractor shall establish test procedure in accordance with the requirements of this specification which will be used as guide in the performance of field test and inspection for all works furnished. The test procedure shall be submitted to NPC for review and approval.

Upon completion of works, the Contractor shall conduct and perform test and inspection for the system's equipment furnished which will be in accordance with the approved test procedure. The tests shall be performed in the presence of NPC representative. Prior to start of tests, the Contractor shall notify NPC of the date when such tests are to be performed.

Any defect found during the tests shall be rectified by the Contractor in the same manner described herein.

#### **MW-3.6.1 Weld Inspection**

##### **a) Butt Welds**

Complete penetration and fusion is required for welds joining shell plates to shell plates. Inspection for quality of welds shall be made

by liquid penetrant testing method. Where visual inspection by NPC inspector indicates unsatisfactory welds, acceptance or rejection shall be based on inspection of liquid penetrant test results.

**b) Fillet Welds**

Fillet welds are welds of approximately triangular section joining two (2) surfaces approximately at right angle to each other as in lap joint, tee joint or corner joint.

Inspection of fillet welds shall be made by visual examination. Where visual inspection by the NPC inspector indicates unsatisfactory welds, acceptance or rejection shall be based on sectioning such areas by chipping with a mechanical round-nosed chipping tool.

**c) Cost**

All costs for liquid penetrant testing and any necessary repairs shall be borne by the Contractor. However, if the NPC inspector requires liquid penetrant testing in excess to the number specified in this Section or requires chipouts of fillet welds in excess of one per 30m (100') of welds is disclosed, the cost of the additional inspection shall be borne by NPC.

**MW-3.6.2 Methods of Inspecting Vertical and Horizontal Joints**

Liquid penetrant examination is required for shell butt welds, annular plate butt welds and flush-type connection with butt welds. Inspection by liquid penetrant examination shall not be required for roof plate or bottom plate welds nor for welds joining roof plates to the top angle, top angle to shell plate, shell plates to bottom plates or appurtenances to tanks.

The method of liquid penetrant examination shall be in accordance with Section V, of ASME Code and applicable editions/addenda. The examination shall be performed in accordance with a written procedure prepared by the Manufacturer in compliance with the applicable requirements of Section V of the ASME Code.

All materials to be used shall be of a recognized commercial quality per manufacturer's recommendation.

Liquid Penetrant Examination shall be properly recorded and documented and submitted to NPC including rejectable indications and its location and extent.

Any defect found during the tests shall be rectified by the Contractor.

**MW-3.6.3 Tank Testing**

**a) Testing Tank Bottom Welds**

Upon completion of welding the tank bottom, all joints shall be tested by vacuum using a soap film solution.

**b) Testing Tank Shell**

Upon completion of the entire tank and the performance of weld inspection specified in Section MW-3.5.1, the tank shell shall be tested by one of the following:

- b.1 If water is available, the tank shall be filled with water and inspected frequently during the filling operation. Filling of water shall be 50mm (2") above the top leg of the top angle;
- b.2 If water is not sufficient to fill the tank, the test shall be made by one of the following:
  - b.2.1 Painting all joints on the inside with a highly penetrating oil and carefully examining the outside of the joint for leakage.
  - b.2.2 Applying vacuum to either side of the joints or applying internal air pressure as specified in Item c) of this Section and carefully examining the joints for leak.

**a) Testing Tank Roof**

Upon completion, the tank roof shall be tested by applying internal air pressure or external vacuum to the seams with a soap film solution. The internal pressure shall not exceed the weight of the roof plates.

**MW-3.6.4 Repairs****a) Repair of Welds**

All defects found shall be called to the attention of the NPC inspector and his approval shall be obtained before they are repaired. Pinhole leaks or porosity in tank bottom joints may be repaired by applying an additional weld bead over the defective area. Other defects or cracks in tank bottom joint or leaks in shell joints or in the shell-to-bottom joints shall be required by chipping or melting out the defects from one or both sides of the joint, as required, and rewelding. Only sufficient cutting out the defective joints is required as is necessary to correct the defects. Isolated pinhole leaks in roof joints may be caulked mechanically. Considerable porosity in the roof joints or of cracking shall be added with bead of weld metal laid over the affected portion. Mechanical caulking is not permitted for any other repairs. Repairs of defect discovered after the tank has been subjected to hydrostatic test shall be made with the water level at least 300 mm (1') below the point being repaired or with the tank empty if repair is on or near the tank bottom.

All repaired welds shall be checked by repeating the original inspection procedure and by repeating one of the testing methods.

**MW-3.7 Tank Calibration**

The tank shall be calibrated for accurate measurement of Diesel Fuel Oil. Five (5) copies of calibration table shall be furnished by the Contractor to NPC.

The Contractor shall include the supply of three (3) sets of 10 meter long Fuel Oil Tank Sounding Tape. Tape body/frame shall be of aluminum alloy with stainless steel tape and brass dropper.

**MW-3.8 Painting Requirements**

**MW-3.8.1 General**

The tank and other surfaces shall be painted in accordance with first class standard practices suitable for the purpose.

All paints and shop primer to be used shall be of standard types of a well-known manufacturer subject to the approval of NPC.

**MW-3.8.2 Surface Preparation**

Prior to painting all weld spatter, mill scale, burrs, rust, loose particles, and flux shall be removed. Grinding and deburring shall be performed with a wheel that will assure a clearly cut surface.

Blast cleaning with iron-free sand or grit shall be used. The grit shall be new and unused. Surface preparation of external surface of tank that will be carried-out at the site shall be done by power tool cleaning to avoid scattering of abrasives caused by blast cleaning.

All cleaned surfaces shall be primed within six (6) hours or before any rust bloom forms on the blasted surface.

**MW-3.8.3 Painting Application**

Application of painting shall be in accordance with the Manufacturer's recommendations and standard practices. No painting shall be applied on wet or damp surfaces.

The tank external surfaces, appurtenances and other surfaces shall be painted to conform with the following:

- a) Primer Coat (75 microns DFT) : Zinc rich epoxy polyamide primer
- b) Intermediate Coat (100 microns DFT) : Epoxy polyamide
- c) Final Coat (50 microns DFT) : Polyurethane enamel

The tank inside surfaces including structural shall be painted to conform with the following:

- a) Primer Coat (50 microns DFT) : Zinc rich epoxy polyamide primer
- b) Intermediate Coat (100 microns DFT) : Polyamide amine cured epoxy coating
- c) Final Coat (100 microns DFT) : Polyamide amine cured epoxy coating

The underside of the tank bottom shall be coated with coal tar epoxy, 400 microns DFT.

The Contractor shall provide test instruments used for testing dry film thickness.

Should the measured dry film thickness result to less than the specified one, the Contractor shall apply additional paint to the coat inspected or shall increase the thickness of succeeding coat, as applicable, to conform with the specified total dry film thickness.

Final color of paint on external surfaces of the tank shall be silver or as directed by NPC. Final color of associated piping and equipment shall be similar to the existing facilities unless otherwise directed by NPC.

**MW-4.0 FUEL OIL TRANSFER PUMP**

**MW-4.1 General**

The fuel oil transfer pump shall be used for unloading/transferring of diesel oil from a tanker/lorry or 210-liter drum to FOST; and from FOST to Day Tank.

The pumps shall be installed inside the respective plant pump house complete with concrete foundation, anchor bolts and electrical amenities and shall conform to the requirements of relevant Civil and Electrical Works Specifications.

**MW-4.2 Scope of Works**

The works shall include the supply and installation of associated valves, strainers, gauges, power cables, controls and other accessories necessary for the safe and reliable operation of the fuel oil transfer pump, but not limited to the following:

**a. Patnanungan DPP**

- a.1 One (1) set of Fuel Oil Transfer Pump, with capacity not less than 10m<sup>3</sup>/hr at a discharge head of 30m, shall be supplied, installed and tested complete with accessories necessary for the safe and reliable operation of the pump including spare parts as specified and recommended by the manufacturer for one (1) year operation and its concrete foundation, anchor bolts, pump house and spare parts for one (1) year operation;



- a.2 Five (5) units of 65 mm Ø Gate Valve;
- a.3 Two (2) units of 65 mm Ø Swing type Check Valve @ F.O. Transfer Pump outlet and pump's bypass line;
- a.4 One (1) unit of 50 mm Ø Swing type Check Valve;
- a.5 Seven (7) units Globe Valve, 25mm Ø, cast bronze, flanged or screwed ends, OSY or rising stem, Class 150
- a.6 Two (2) units of 65 mm Ø Simplex Strainer (40 mesh size);
- a.7 Two (2) units of 100 mm Ø dial size Pressure Gauge @ F.O. Transfer Pump Inlet and outlet;
- a.8 One (1) unit of 10 m<sup>3</sup>/hr rated flow Flowmeter, 65 mm Ø @ downstream of F.O. Transfer Pump; and
- a.9 One (1) lot of Piping Materials, pipe fittings, pipe supports, pipe coating and other accessories including any required excavation and backfilling works.

**b. Palanan DPP and Jomalig DPP**

- b.1 One (1) set of Fuel Oil Transfer Pump, with capacity not less than 10m<sup>3</sup>/hr at a discharge head of 30m, shall be supplied, installed and tested complete with accessories necessary for the safe and reliable operation of the pump including spare parts as specified and recommended by the manufacturer for one (1) year operation and its concrete foundation, anchor bolts, pump house and spare parts for one (1) year operation;
- b.2 Sixteen (16) units of 65 mm Ø Gate Valve;
- b.3 Six (6) units of 25 mm Ø Globe Valves @ fuel oil supply lines to existing fuel day tanks;
- b.4 Six (6) units Globe Valve, 25mm Ø, cast bronze, flanged or screwed ends, OSY or rising stem, Class 150
- b.5 Two (2) units of 65 mm Ø Simplex Strainer (40 mesh size);
- b.6 Two (2) units of 100 mm Ø dial size Pressure Gauge @ F.O. Transfer Pump Inlet and outlet;
- b.7 One (1) unit of 10 m<sup>3</sup>/hr rated flow Flowmeter, 65 mm Ø @ downstream of F.O. Transfer Pump; and
- b.8 One (1) lot of Piping Materials, pipe fittings, pipe supports, pipe coating and other accessories including any required excavation and backfilling works.

**MW-4.3 Design and Construction**

The pump shall be horizontal gear type with a capacity of not less than 10 m<sup>3</sup>/hr at a discharge head of 30m. Pump casing shall be made of cast iron material capable of withstanding a hydrostatic pressure of 150% of the maximum pumping pressure under which the pump could operate at design speed.

The fuel oil transfer pump shall conform, as minimum, to the following requirements:

- |            |   |                            |
|------------|---|----------------------------|
| a) Casing  | : | Cast Iron                  |
| b) Gear    | : | Ductile Iron               |
| c) Shaft   | : | High Strength Carbon Steel |
| d) Bushing | : | Bronze (Graphited)         |

Gland shall be made of cast iron stuff with graphite gland packing. Oil pan shall be provided at the gland section to catch possible oil leaks.

Pump shall be equipped with adjustable safety valve or relief valve to protect the unit from overpressure. Safety valve box and cover shall be made of cast iron.

Lifting lugs and eyes and other special tackle shall be provided as necessary to permit easy handling of the pump and its components.

The pump shall be driven by a direct-coupled motor mounted on a common metal base ready for installation on concrete foundation. Concrete foundation and anchor bolts shall be included in the scope of work and shall conform to the general requirements of relevant Civil Works Specifications.

Pump Motor shall be selected so that the pump brake HP requirement throughout the entire capacity range shall be within the nameplate rating of the motor. Motors shall be capable of operating continuously at rated output within  $\pm 5\%$  of rated frequency and at any voltage within  $\pm 10\%$  of rated value.

Pump motor shall generally be of the squirrel cage rotor induction type and shall comply with ANSI Standards plus amendments. Standard frame sizes should be used.

Pump Motor shall be of the totally enclosed guarded fan cooled type, suitable for continuous operation and direct on line starting. Motors shall conform to the requirements specified in the electrical Works specifications. The pump to be supplied shall be operated at 240 V/1 $\phi$ /60 hz.

Local panel shall be provided at the fuel pumphouse and in the powerhouse. Local Panel at the Powerhouse shall be located midway of the fuel day tanks' area. Each local panel shall be provided with start and stop push buttons with respective status indicating lights. Local panel at the pump house shall be provided with local/remote selector switch which shall be utilized for preference of fuel pumps operation either from the

powerhouse or fuel pump house. Provisions for monitoring of Start and Stop status for the pump in the Control Room Panel shall also be provided.

All cables and conduits including ground wire of appropriate size required for the connection of the motor to the existing station panelboard shall be provided by the Contractor in coordination with the plant management.

The Contractor shall furnish a UL/CSA listed moulded-case circuit breaker equipped with thermal magnetic trip current protection, rated 100 AT, 240V, 1-phase, 60 Hz in an enclosure to be installed in the pump house and another unit of circuit breaker shall be provided and installed at the power station to be tapped at the existing 240 V system for the power source supply.

The local control panel shall be provided with start and stop push buttons with status indicating lights.

All cables and conduits of appropriate size required for the connection of motor from the existing station's panelboard shall be provided by the Contractor. Cable size shall not be less than the requirements in the Electrical Works Technical Specifications.

The technical requirements of the associated valves, flowmeter, strainers, gauges, testing and spare parts shall conform to the requirements specified in this section.

#### **MW-4.4 Spare Parts**

The Contractor shall supply the manufacturer's recommended spare parts for one (1) year operation of pump to be supplied which shall include the following as minimum:

- a) One (1) set of bearings for pump and motor; and
- b) One (1) set of bushings, wearing rings, packing and gaskets for the pump.

#### **MW-4.5 Pump House**

**Palanan DPP:** The Contractor shall renovate/rehabilitate the existing guardhouse at Palanan DPP (Refer to relevant Electrical and Civil Works Technical Specifications and drawings).

**Patnanungan DPP and Jomalig DPP:** The Contractor shall construct a new pump house to house the fuel transfer Pump in accordance with the attached Civil Work drawings. The pump house shall be provided with lighting, drainage system and other amenities to conform with the requirements specified in this section and in the relevant Electrical and Civil Works Technical Specifications and drawings.

Lighting fixture to be used shall be of compact LED type, 9 watts, 230V, vapor tight and fitted with clear glass globe.

Each Pump house shall be provided with the following:

- a) One (1) unit of (Convenience Outlet) 16 Amps, 230 V, duplex;
- b) One (1) unit of (Single) Convenience Outlet rated 16 Amps, 230 V;
- c) One (1) unit Single pole switch rated, 10 Amps, 230 V, 1 gang; and
- d) 2 x 2 Watts, 230 V, Emergency Lighting Fixture

#### **MW-4.6 Submittal**

The Contractor shall submit for NPC evaluation and approval for the following:

- e) Catalogues or brochures for pumps and associated electrical device technical data, outline drawings, including detailed drawings of pump's concrete foundation;
- f) Test procedures prior to test; and
- g) Test and inspection reports

#### **MW-4.7 Pump Testing**

The pump and motor shall be subjected to factory tests to determine its conformance with the design and operating characteristics and shall be performed in accordance with the approved test procedures and applicable codes and standards which shall include the following:

- a) Pressure hydrostatic proof of the spiral case to 1.5 times the maximum pressure for 30 minutes;
- b) Report of the characteristic curve of at least one (1) pump of each type such as Height vs. Flow, Power absorbed against Flow, Efficiency against Flow;
- c) Test of uninterrupted operation to full flow and maximum height of each pump motor set for one (1) hour; and
- d) Test of uninterrupted operation without load for each pump motor set for one (1) hour.

#### **MW-4.8 Painting**

Pump's associated valves and other accessories are generally delivered with final paint applied at the manufacturer's shop. Any part of the final paint that will be damaged during transport and installation shall be re-painted or touched-up after installation and testing. Final color shall be per manufacturer's standard unless otherwise directed by NPC.

### **MW-5.0 FUEL OIL TRANSFER AND WASTE OIL/WATER PIPING SYSTEM**

#### **MW-5.1 Scope of Works**

The Contractor shall supply, install and test a complete Fuel Oil Transfer and Waste Oil/Water Piping System including pipe supports, fittings, necessary accessories, all required excavation and backfill of pipe

trenches, painting and other necessary accessories as required and shown on the attached drawings.

The F. O. Transfer piping system shall consist of piping interconnections for a rubber hose at fuel oil transfer pump inlet, pump bypass line from a fuel oil delivery truck up to the storage tank and storage tank to day tank through fuel oil transfer pump.

Waste Oil/Water shall consist of piping interconnections from the Fuel Oil Tank's drain pit to oil-water separator and waste water from oil-water separator to existing drainage system or to a discharge area.

The works shall include the supply and installation of piping materials, valves, asphalt tape/jute of embedded fuel oil piping and other accessories to complete and make ready for the safe and reliable operation of the fuel oil transfer system but not limited to those shown on the attached drawings.

#### **MW-5.2 Piping**

Fuel oil piping shall be constructed from ASTM A53 Gr. B, seamless pipe and Schedule 40. All piping 65mm and larger shall be constructed with flanged joints or butt-welded joints and fittings. Piping 50mm and below shall be constructed with flanged joints or socket welded joints and fittings.

Fuel oil piping shall generally be installed above ground. In case fuel oil piping shall be installed underground, subject to the approval of NPC, steel pipes laid underground shall be applied with two (2) coats of Coal Tar epoxy polyamide of 170 microns DFT each coat prior to application of asphalt jute. Asphalt jute of 6 mm thickness or approved equivalent shall be applied to the external surface of pipes laid underground.

Waste oil/water piping shall be constructed of Unplasticized Polyvinyl Chloride (*uPVC*) pipe, Schedule 80 or Class 150, conforming to ASTM D-1784 or approved equivalent.

Unplasticized PVC pipe connection joints 80 mm (3") Ø and above shall be joined by rubber ring or solvent cement type connection. Smaller sizes shall be of solvent cement type connection. Flanged connections shall be used for connecting to flanged surfaces or to flanged-ends valve and shall be of the same material with the connected pipe with a rating of Class 150 or ANSI 150.

The waste oil/water piping system shall generally be laid underground. All trenches shall be provided with a cushion pad of at least 100mm sand and sandy soil bedding materials. All pipeline excavations shall be backfilled up to the level of the finished grade surface in layers of 150mm and each layer shall be thoroughly compacted. Backfill materials shall be compatible soil taken from trench excavation and approved by NPC.

All pipes that crosses roadways shall be provided with pipe sleeve made of steel material or RCP pipe to protect the pipe from various loads imposed by vehicles and shall extend 600mm beyond shoulder of each

pavement side. Embedded pipes in open areas shall be laid not less than 300mm from the ground surface to the bottom of pipe.

PVC pipe installed aboveground or with associated isolation valve shall be properly supported to avoid pipe sagging. Pipe covering made of steel or metal shall be provided in case there is high risk of damaging the pipe during normal operation and maintenance.

All trench excavation and backfill works shall be done in accordance with pertinent provisions specified in the Civil Works Specifications.

#### **MW-5.3 Valves**

All gate or globe valves to be supplied shall be of the outside screw and yoke design or with rising stems. Valves body material shall be of cast iron for sizes more than 50mm diameter and cast bronze or stainless steel for 50mm and smaller. All valves shall have flanged ends with a rating of not less than 150 lb. The use of screwed ends may be applied to 50 mm diameter subject to the approval of NPC. Check valves shall be of swing type.

#### **MW-5.4 Strainers**

Strainers shall be of basket type or approved equivalent with body cast iron material and flanged ends. Body drain and vent connections shall be included. Drain plugs shall be threaded. Screen elements shall be of stainless steel construction with minimum 32-mesh size or as shown on the drawings. Magnets shall be included to trap small iron and steel particles for use in fuel oil lines.

#### **MW-5.5 Pressure Gauges**

Pressure gauges for fuel oil system shall be provided with dampener. Each pressure gauge shall be provided with isolation valve. Pressure gauge shall be of bourdon tube type with solid front case, and minimum size of dial gauge shall be of 100mm Ø.

#### **MW-5.6 Flowmeters**

Flowmeter shall be provided at fuel oil system. Accuracy of flow meters shall be  $\pm 0.5\%$  of total flow with 0.2% repeatability. Flowmeters shall be of LCD display and capable of monitoring the Total/Accumulated Flow, resettable total flow and instantaneous flow rate. Flowmeter shall be selected so that the designed flow in the fuel supply and return line shall be between 50% to 75% design regions, of the flow meter. Simplex strainer with minimum 60 mesh size and stainless steel filter element shall be provided upstream of the flowmeter. The flowmeter shall be made of aluminum or approved equivalent with flanged ends and shall utilize an internal battery that can last up to at least 5 years. The flowmeter shall be equipped with pulse generator or 4-20mA current output and ready for future interconnections.

**MW-5.7 Testing**

The piping system shall be hydrostatically tested at a pressure of 1.5 times the operating pressure of the system.

The assembled fuel oil piping system may be tested using a compressed air at a pressure of 1.25 times the operating pressure of the system and maintaining it for a minimum of 10 minutes, subject to the approval of NPC. Examination for leakage detected by soap bubble or equivalent method shall be made of all joints and connections. The piping system shall show no evidence of leaking.

During initial pipe filling and trial operation of the fuel oil piping system, piping fittings and joints shall be visually inspected against leak.

Waste oil/water may be applied to sections or the entire system. The test shall be made between valves and sections of not more than 305 m (1000 ft.) in accordance with the American Water Works Association (AWWA). There shall be no leakage whatsoever from the pipes, fittings and connections for each section tested while the system is under test pressure for the period of not less than thirty (30) minutes or the total time to inspect all portions of the waterline under test, whichever is longer. During the test, valves shall be opened and closed. Any leakage or any defect disclosed by the tests prior to the acceptance shall be corrected and repaired by the Contractor at his own expense to the satisfaction of NPC.

Before any test is made, the Contractor shall notify NPC in advance so that such test may be witnessed. All expenses that may be incurred during the tests shall be borne by the Contractor.

**MW-5.8 Painting**

All steel piping installed outdoors and indoors shall be prime coated with 80 microns DFT zinc rich epoxy paint and 80 microns DFT of chlorinated rubber for each intermediate and topcoat.

All steel pipes laid underground shall be applied with two (2) coats of Coal Tar epoxy polyamide of 170 microns DFT each coat and finally wrapped with 6mm thickness asphalt jute.

Painting for waste oil/water PVC piping is not required.

Final color for Fuel Oil piping and associated valves installed above ground shall conform to Munsell No. 7.5R 3/12 and/or similar to the existing facilities or as directed by NPC.

**MW-6.0 FIRE EXTINGUISHER SYSTEM****MW-6.1 General**

This section provides the essential information for the design, manufacture, fabrication, supply, installation, delivery to site and test of the specified Fire Extinguisher System.

All equipment and materials necessary for the complete installation shall be furnished complete, even though not necessarily mentioned in this specification but are necessary for the safe and reliable operation of the Fire Extinguisher System.

All the Fire Fighting System equipment shall be supplied by the Contractor complete with their corresponding technical brochures written in English that would aid in the installation, operation and maintenance of the equipment.

The Fire Extinguisher System shall be designed, installed and tested in accordance with the requirements of National Fire Protection Association (NFPA) Standards.

The Contractor shall design, furnish, install and test all the equipment specified below.

**MW-6.2 Portable Fire Extinguishers****MW-6.2.1 Scope of work**

The Contractor shall supply the specified number of UL/FM approved Portable Type Fire Extinguishers per plant complete and ready for operation and shall be installed at their corresponding place of use as specified below and shown on the drawings.

- a.1 Supply and installation of three (3) sets of Foam (AFFF) wheeled type fire extinguisher, UL/FM approved, complete with self-contained cylinder mounted on a frame with handle, floorstand and steel wheels, 125 L (33 gallons) capacity complete with associated valves, dial gauge indicator, nitrogen expellant tank for unit pressurization, appropriate size of discharge hose of 15 m long fitted with couplings and foam nozzle assembly;
- a.2 Supply and installation of three (3) units of Portable Type Fire Extinguisher, Clean Agent (HCFC or Halotron I Type), 7.1 kg. (15.5 lbs), wall-hung type and UL/FM approved, for the pumphouse;

**MW-6.2.2 Technical Requirements**

Fire extinguishers shall be Underwriter Laboratories and/or Factory Mutual approved and of rechargeable cylinder with five (5) years guarantee against leak. Each fire extinguisher cylinder shall be complete with release valve, dial gauge indicator, appropriate length of hose with nozzle and locking pin.



The 7.1 kg (15.5 lbs.) capacity wall-hung type fire extinguishers shall be complete with carrying handle and wall-mounting bracket. Portable fire extinguishers shall be suitable for the protection against class ABC fires using Clean Agent (HydroChloroFluoroCarbon or Halotron I Type) that is environmentally safe and leaves no residue.

The Foam (AFFF) wheeled type fire extinguisher units shall consist of a completely self-contained cylinder mounted on a frame with handle, floorstand and steel or rubberized wheels, 125 L (33 gallons) capacity complete with associated valves, dial gauge indicator, nitrogen expellant tank for unit pressurization, appropriate size of discharge hose of 15 m long fitted complete with couplings and foam nozzle assembly.

The fire extinguishers shall be check-weighed at interval of six (6) months from the date of delivery for a period of one (1) year and if found to be undercharged (unless used by an NPC personnel) shall be filled and recharged by the Contractor at no expense to NPC.

Painting of Fire Fighting Equipment and applicable piping shall be in accordance with the requirements of Section GW-10.3 of the General Works Specifications. Final color to be used for all fire fighting equipment shall be Munsell No. 7.5 R 4/14.

#### **MW-6.2.3 Submittals**

The Contractor shall submit the type and model of the fire extinguishers for the approval of NPC prior to purchase.

#### **MW-7.0 EQUIPMENT MARKING AND LABELING**

All equipment and devices to be supplied by the Contractor under this contract shall be provided with a corrosion-resistant nameplate with clearly legible writing of approved size and pattern and shall be permanently attached at an easily visible place. It shall provide all necessary information or brief technical description under which the equipment has been designed to operate and shall include the following: manufacturer's name; type of equipment; serial number; year of manufacture; weight and other relevant information in compliance with applicable standards.

All labels and nameplates shall be of engraved stainless steel or equivalent non-corrodible material.

Tag Numbers for instruments and other devices shall also be provided as necessary and practicable.

Appropriate labels shall also be provided for equipment and devices mounted on control boards, relay cabinets, desks, and other places as required for proper identification, as well as for operational, functional, and safety reasons.

The labeling, size of label plates, and their location shall be subject to approval by NPC. A sample label-plate (with indication of material used) with lettering shall be submitted for this purpose. The inscription shall be printed or stenciled but in any case, water-proof, oil-proof and wear-resistant.

Each equipment, wherever necessary, shall be provided with cautionary and warning plates and signs.

Nameplates, labels, and warning plates shall be in English.

The nameplates and labels shall be protected during erection especially during painting. Damaged or illegible labels or nameplates shall be replaced by new ones.

No separate payment shall be made by NPC for nameplates and labels. Corresponding costs thereof shall be included by the Contractor in the bid price for each equipment to be furnished under the Contract.

#### **MW-8.0 GUARANTEE**

The Contractor shall guarantee that he will repair, and/or replace, at his own expense, equipment and materials against defect in design, materials and workmanship for a period of twelve (12) months after the issuance of the Certificate of Completion. The Contractor guarantees that when the equipment and/or material are placed in operation and/or use, it will perform in the manner as set forth in the Contract.

#### **MW-9.0 MEASUREMENT OF PAYMENT**

Measurement of payment for all Mechanical Works shall be based on the bid price of each item in the Bill of Quantities. The cost shall cover all works required and described in the pertinent provisions of the specifications.

# PART I

# TECHNICAL SPECIFICATIONS

# EW - ELECTRICAL WORKS

**PART I - TECHNICAL SPECIFICATION**

**EW-ELECTRICAL WORKS**

**TABLE OF CONTENTS**

<u>CLAUSE NO.</u>	<u>TITLE</u>	<u>PAGE NO.</u>
EW-1.0	GENERAL.....	2
EW-2.0	SCOPE OF WORK.....	2
EW-3.0	STANDARD OF MATERIALS .....	2
EW-4.0	LIGHTING AND POWER SYSTEM .....	3
EW-4.1	Technical Requirements and Characteristics.....	3
EW-4.2	Lighting Fixtures, Luminaires and Accessories.....	4
EW-4.2.1	Lighting Fixtures.....	4
EW-4.2.2	Luminaires.....	4
EW-4.3	Conductors.....	5
EW-4.3.1	Conductor Installation .....	5
EW-4.4	Conduit System.....	5
EW-4.4.1	Non-Metallic Conduits.....	6
EW-4.5	Junction / Utility and Pull Boxes .....	6
EW-4.5.1	Junction / Utility Boxes.....	6
EW-4.5.2	Pull Boxes .....	6
EW-5.0	CONTROL, PROTECTION AND MONITORING PANELS OF MOTOR PUMP....	6
EW-5.1	Technical Requirements and Characteristics.....	7
EW-5.1.1	Panel Construction.....	7
EW-5.1.2	Combination Motor Starter and Breaker Unit .....	7
EW-5.1.3	Nameplate.....	9
EW-5.1.4	Equipment Grounding.....	10
EW-6.0	DATA AND DOCUMENTATION REQUIREMENTS .....	10
EW-7.0	MEASUREMENT OF PAYMENT.....	10

## EW - ELECTRICAL WORKS

### EW-1.0 GENERAL

The works to be done under these specifications consist of Lighting and Power System for Fuel Oil Storage Tank (FOST) Pump House for Patnanungan DPP, Palanan DPP and Jomalig DPP.

### EW-2.0 SCOPE OF WORK

In accordance with the specification contained in this section and as shown on the bid drawings, the scope of this contract shall include all engineering services such as furnishing, installation, testing and commissioning of electrical devices and materials.

The works required are as follows:

1. Supply, Installation and Test of Pump Motor Power Supply including necessary control, monitoring and protective devices;
2. Supply, Installation and Test of Power and Lighting System;
3. Supply, Laying and Test of Insulated Copper Conductors; and
4. Supply and Installation of Conduit System.
5. Dismantling of Lighting Fixture, Convenience Outlet, Cables and Conduits for Palanan DPP.

In addition, the following shall be provided by the Contractor:

1. Provision of services of a highly qualified and competent Electrical Engineer with experience in the implementation of electrical works to perform/direct supervision during installation and test of all supplied devices, including cabling works;
2. Conduct of inspection to verify and assess the extent of the related and incidental works needed to implement the project competently and efficiently; and

The Contractor shall bear full responsibility that the materials have been designed and fabricated in accordance with all codes, standards, and applicable governmental regulations and performs under the conditions and to the standards specified herein.

### EW-3.0 STANDARD OF MATERIALS

All materials to be used in the work shall be new, of high quality, free from all defects and of proven acceptability for the intended purpose. Unless otherwise specified, materials shall conform to the latest applicable standard issued by the following authorities:

1. American National Standards Institute (ANSI)
2. International Electrotechnical Commission (IEC)
3. Institute of Electrical and Electronic Engineers (IEEE)
4. Underwriter's Laboratory (UL)
5. National Electrical Manufacturer's Association (NEMA)
6. National Electrical Code (NEC)
7. Philippine Electrical Code (PEC)

Other recognized national standards may be accepted if, in the opinion of NPC representatives, such will guarantee a quality not inferior to that guaranteed by the above standards.

In case of conflicting requirements between authorities cited above and those specified, such disagreement shall be resolved by representative of whose decision shall be final.

#### **EW-4.0 LIGHTING AND POWER SYSTEM**

The lighting and power system covered by this specification includes lighting and power outlets (convenience and power), switches, associated conduits and cables, lighting fixtures (indoor and emergency), fittings, transformer, fuse disconnect switch with lightning arrester combination, etc.

The devices/materials furnished shall be in accordance with, but not limited to, the latest issues of the Applicable Codes and Standards, including all addenda, in effect at time of purchase order unless otherwise stated in this specification.

All materials and parts which are not specifically mentioned herein but are necessary for the proper installation and safe operation of the lighting system shall be identified by the Contractor and shall be furnished at no additional cost to NPC.

#### **EW-4.1 Technical Requirements and Characteristics**

Circuit shall be wired for lights and outlets. Lighting fixtures shall be controlled and switched locally approximately as shown on the bid drawings. Power source shall be as indicated on the bid drawings.

Replacement of fixture bulbs or tubes shall be possible without disconnecting any part of the power supply and risk of touching live parts of the installation.

**EW-4.2 Lighting Fixtures, Luminaires and Accessories****EW-4.2.1 Lighting Fixtures**

All lighting fixtures when installed shall be free of leaks, warps, dents and other irregularities.

The hangers and brackets of all kinds for safety and proper installation of lighting fixtures shall be furnished and installed by the Contractor at his own expense.

All lighting fixtures, samples and catalogues shall be submitted for NPC's review and approval prior to the order. No lighting fixtures shall be installed without approval of NPC.

Lighting fixtures shall be wired with approved fixture wire, 90°C insulation. Each fixture shall be wired to a single point with an adequate slack for proper connection. All lighting fixtures shall be protected from damage during installation. Any broken lighting fixtures, receptacles, stems and the like, shall be replaced with new parts, at no cost to NPC.

**EW-4.2.2 Luminaires****a. Compact Light Emitting Diode Lamp**

Compact Light Emitting Diode Lamp shall be cool white frosted finish, rated 240V AC, 60 Hz operations. Lamp holders shall have E27 base.

When used in damp and wet locations, it shall have an explosion and corrosion proof body and sealed.

**b. Automatic Stand Alone Emergency Lamps**

The Contractor shall supply and install the automatic stand-alone emergency lamp of the self-contained battery unit as specified herein.

When the AC main supply is interrupted, the lamps shall be automatically switched ON with a time delay of 1 second to the battery-powered operation. Lamps shall be switched OFF when the batteries are discharged at the low-level voltage (below 7.5V). The charging system of both maximum-constant voltage and constant current shall be able to recharge the completely discharged batteries to their full capacity within 20 hours or less. The charging system shall cut-off automatically and instantaneously upon reaching fully charged state.

Under normal supply, the charging system shall ensure and maintain the batteries in a fully charged state ready to supply power and shall be equipped with a reliable protective device to protect the batteries against overload and short circuit.

Batteries shall be of long life, maintenance free, sealed lead acid type. The batteries shall have sufficient capacity to operate the lamps at full luminous efficiency for up to 3 hours after failure of the main supply.

Rated input voltage of the automatic stand-alone emergency lamps shall be 240 VAC, 1-phase, 60 Hz. Rated output voltage of the batteries shall be 12 Vdc.

### **EW-4.3 Conductors**

Conductor shall be stranded annealed copper conductor suitable for continuous temperature of 90°C. The minimum size of conductor to be used shall be 3.5mm<sup>2</sup>.

Insulation shall be suitable for wet and dry location, fungi resistant and ultra violet stable. All cables shall be moisture and heat resistant thermoplastic or cross-linked synthetic polymer unless otherwise specified by NPC.

#### **EW-4.3.1 Conductor Installation**

Conductors pulled through conduits shall be supported in an approved manner so as to avoid damage to the insulation. Grease or oily substances shall not be used to facilitate the passage of the conductor in conduits.

The pull shall be applied to conductors only by means of approved grips and the end portion of the conductor, which has been marked or deformed by the grip, shall be cut-off by the Contractor.

All conductor runs shall be continuous and all termination shall be at the terminal boards, equipment, etc. No splices are allowed in conduit or cable tray.

Prior to installation of cables, conduits and cable trays shall be thoroughly cleaned to prevent damage to cables during installation. After cables have been installed, cables shall be tested for continuity and insulation resistance and shall be tagged with respective conductor number.

### **EW-4.4 Conduit System**

All embedded and concealed in ceiling conduits, boxes and fitting required for the power and control conductors including all necessary hardware and accessories such as screws, bolts, concrete inserts, clamps, locknuts, couplings shall be furnished by the Contractor. The required quantities of various items of conduits and associated materials shall be furnished in accordance with the installation requirements.

During installation, due precaution shall be taken to protect the conduit and threads from mechanical injury. The ends of the conduit shall be sealed in an approved manner. Conduit runs shall be sealed by the use of caps and discs or plugs. The seals shall be maintained, except during inspection and tests, until the conductor is pulled in. Conduit shall be check to be free from obstructions by pulling a wooden mandrel of appropriate size through the conduit.



Conduits running in floors and terminating at equipment mounted on concrete bases shall be brought up to the equipment within the concrete bases, wherever possible.

All joints between lengths of conduits and threaded connection to boxes, fittings and equipment enclosures shall be made watertight.

Conduits installed outdoors running underground shall be buried to a minimum of 0.6 m.

#### **EW-4.4.1 Non-Metallic Conduits**

Non-metallic conduit shall be made of un-plasticized polyvinyl chloride (uPVC) smooth walled inside and outside, coloured red-orange, schedule 40.

The uPVC conduits shall be non-corrosive and weatherproof, resistant to the attacks of acids and alkalis and must have a self-extinguishing property, hence shall not support combustion. It shall resist corrosion, rust and scale.

#### **EW-4.5 Junction / Utility and Pull Boxes**

##### **EW-4.5.1 Junction / Utility Boxes**

All junction/utility boxes for concealed work shall be of hot dip galvanized steel or un-plasticized polyvinyl Chloride. All wall boxes on exposed work shall be of aluminum blasted cast iron.

Utility boxes shall be firmly anchored in place and where required provided with fixture supports. The Contractor shall provide special supports for recessed lighting fixtures, etc. Suitable expansion screws shall be used for securing boxes to solid masonry and approved type toggles for securing to hollow masonry units.

##### **EW-4.5.2 Pull Boxes**

Pull boxes shall be installed at all necessary points, to prevent damage to the insulation or other damage that might result from pulling resistance or For other reasons related to improper installation. All pull boxes shall be made of galvanized sheet steel not less than 2mm or unplasticized polyvinyl chloride. Where pull boxes are used in connection with exposed conduits, plain covers attached to the pull box with a suitable number of countersunk flathead machine screws may be used.

#### **EW-5.0 CONTROL, PROTECTION AND MONITORING PANELS OF MOTOR PUMP**

The control, protection and monitoring panels covered by this specification shall primarily be comprised of the combination motor starter with breaker unit, measuring devices, indicating lights and other associated components. The panels, depending on the location where it shall be installed, shall provide one or more of the following functions: control,

protection, monitoring and disconnecting means of the FOST Pump Motor to be installed inside the pump house.

#### **EW-5.1 Technical Requirements and Characteristics**

The following are the minimum requirements for the operator interface with the Fuel Oil Storage Tank Pump Motor according to location where the panel shall be installed:

1. Pump House: Control Selection (Local/Remote), Motor Control (Start/Stop), Motor Protection (Relays, Contactors and Circuit Breaker) and Motor Status Display (Indicating Lights)
2. Engine Area: Motor Control (Start/Stop) and Motor Status Display (Indicating Lights)
3. Control Room: Motor Status Display (Indicating Lights)

The protection relay system shall be designed to bring the unit to automatic opening of breaker for electrical fault according to calculated tripping parameters.

The protection scheme shall be provided with adequate number of input/output contacts of suitable rating to carry out the prescribed tripping functions for the initiation of automatic closing/tripping or switching control.

All DC and AC power supply required for control, monitoring and protection of the system shall be integrated in the panels. The power and voltage requirements will be determined by the manufacturer in accordance with the ratings and consumption of its equipment/device.

The Contractor may offer a motor control, protection and/or monitoring panel with proprietary standard design of the manufacturer containing the required functions suitable to the offered pump motor.

##### **EW-5.1.1 Panel Construction**

The panel shall be constructed from a minimum of 2.0 mm thickness steel sheet with edges formed into a rectangular pattern welded steel sheets so that each section is rigid, self-supporting and enclosed. It shall be adequately protected and suitable for indoor and outdoor application and all climate condition.

The panel shall be labeled with ISO symbols and comply with IP 65 for external environmental resistance and IP 44 and NEMA 12 for the resistance of the internal sealed modules.

##### **EW-5.1.2 Combination Motor Starter and Breaker Unit**

The combination magnetic full voltage starter unit shall include contactors with manual reset thermal overload relays; and operating coils. The smallest combination starter unit shall be NEMA Type 1 or equivalent to IEC standard.

The combination starter unit shall have a symmetrical interrupting rating which exceeds the available short circuit current not less than 10,000 amperes.

Starter overload relay contacts, contactor operating coils, and starter auxiliary contacts shall be wired to marked unit terminal blocks.

Starters shall reliably operate with 85% of rated bus voltage applied and shall not drop out at voltage lesser than 75 % of rated bus voltage.

Combination starter units furnished shall be full voltage single-speed non-reversing (FVNR) or full voltage single-speed reversing (FVR) as determined by the Contractor and approved by NPC.

#### **EW-5.1.2.1 Circuit Breaker**

The combination motor starter unit shall include one miniature circuit breaker or molded case circuit breaker with symmetrical interrupting of at least 10,000 amperes or greater as determined by the Contractor. All breakers shall be manually operated with quick-make, trip-free mechanism of the toggle type.

The breakers shall be equipped with suitable arc quenching devices. Main current carrying contacts shall be silver plated and shall be capable of carrying their rated current without exceeding the Underwriters' Laboratories specified temperature rise. All circuit breakers shall be of the same manufacturer.

#### **EW-5.1.2.1 Starter Contactors**

The rated continuous current carrying capacity of each starter contactor to be used shall be as listed in NEMA or IEC Standard. Contactors shall be applied in accordance with their kW rating only. The interrupting capacity of each starter contactor shall be not less than 10 times the rated continuous current carrying capacity.

The electrical life, without maintenance, of each starter contactor to be used shall be not less than 500,000 operations with each opening or closing of the load contacts to constitute one complete operation. The mechanical life of each starter contactor shall be not less than 5,000,000 operations.

Combination starter units which require line voltage to energize the main contactor operating coils or those for which main contactor coil inrush exceeds 600VA shall be equipped with auxiliary contactors (interposing relays) for use in the operating coil circuit.

#### **EW-5.1.2.2 Overload Relays**

All starters shall be equipped with overload relays and shall operate within a range of plus or minus 5 percent of the overload relay trip setting. Assemblies which do not meet this requirement both when field tested and when in actual operation shall be replaced by the Contractor.

Alternative proposal shall be considered based on furnishing bimetallic type temperature compensated overload relays or electric alloy type overload relays, provided that such proposals are accompanied by manufacturing information clearly indicating details of construction and experience records of the overload relay proposed.

**EW-5.1.2.3 Mechanically Operated Auxiliary Contacts** (As applicable, to be determined by the Contractor)

Each single-speed non-reversing starter shall be furnished with a total of six (6) mechanically operated auxiliary contacts, three (3) normally open and three (3) normally closed, mounted in the main contactor.

If required, each single-speed reversing starter shall be furnished with a total of eight (8) mechanically operated auxiliary contacts, four (4) normally open and four (4) normally closed, mounted on each forward and each reversing main contactor.

If required, each two-speed non-reversing starter shall be furnished with a total of ten (10) mechanically operated auxiliary contacts, three (3) normally open and two (2) normally closed, mounted on each main contactor.

Auxiliary contacts shall be operated by the contactor, not by the operating handle or its mechanism. Contacts shall be wired out to terminal blocks. One (1) NC contact shall be for motor space heater use and shall be rated for 10 amperes or larger.

The use of auxiliary relays to furnish the specified quantities of auxiliary contacts will not be acceptable.

**EW-5.1.2.4 Remote Control**

Each magnetic starter will be controlled by remote contacts. All necessary internal wiring for this feature shall be furnished and connected to terminal blocks.

**EW-5.1.2.5 Indicating Lights**

Each reversing starters shall be furnished with two (2) indicating lights on the door to indicate open/close status. Each non-reversing starter shall be furnished with two (2) indicating lights on the door to indicate when the motor is stopped or running.

**EW-5.1.3 Nameplate**

The panel shall be provided with adequately sized nameplate made of black surface exposing the white core. In addition, each piece of equipment mounted on or inside the panel shall also be provided with nameplate for easy and convenient identification.

**EW-5.1.4 Equipment Grounding**

The motor control, protection and monitoring panels shall be properly grounded in accordance with the latest electrical and electronics industry standards.

**EW-6.0 DATA AND DOCUMENTATION REQUIREMENTS**

Contractor-furnished data and information shall be guaranteed performance data, predicted performance, interface requirements and construction features of all Contractor's furnished equipment. The accuracy of such information and its compatibility with overall performance requirements specified by NPC are the sole responsibility of the Contractor.

All information submitted as part of Proposal Data would become part of contract data for successful bidder. Any deviation from such data requires NPC's approval.

**EW-7.0 MEASUREMENT OF PAYMENT**

Measurement of payment for all electrical works shall be based on the bid price of each item as shown in the Bill of Quantities – Electrical Works, Section VII of the Bid Document. The cost of each item shall cover all works required and described in the pertinent provisions of the specifications.

# SECTION VI

# TECHNICAL SPECIFICATIONS

## PART II - TECHNICAL DATA SHEETS

**PART II – TECHNICAL DATA SHEETS**

**MW – MECHANICAL WORKS**

**TABLE OF CONTENTS**

<b>SECTION</b>	<b>DESCRIPTION</b>	<b>PAGE</b>
M-1.0	Fuel Oil Storage Tank	VI-TDS(MW)-2
M-2.0	Fuel Oil Transfer Pump	VI-TDS(MW)-3
M-3.0	Fire Extinguishers	VI-TDS(MW)-4

**NOTES:**

1. The Bidder shall fill-in all the data as required. The Bidder shall use continuation sheets as necessary for any other additional information keeping to the format shown herein or by reproducing the same.
2. NPC reserves the right to reject Bids without proper data/information as required herein.
3. The data required are technical features and characteristics of equipment and structures to be supplied by the Bidder. Bidder's proposal shall at least be equal or superior than the requirements specified by NPC.



**M-1.0 FUEL OIL STORAGE TANK**

ITEM	DESCRIPTION	UNITS	NPC REQUIREMENT	CONTRACTOR'S DATA
<b>A. Patnanungan DPP</b>				
M-1.1	Capacity (Nominal)	m <sup>3</sup>	35	
M-1.2	Design Code		API 650 or Approved Equivalent	
M-1.3	Quantity	sets	2	
M-1.4	Empty Weight	kg	By Contractor	
M-1.5	Operating Weight	kg	By Contractor	
M-1.6	Size (dia. X height)	m x m	3 x 5.4	
M-1.7	Materials of Construction:			
	Plate	ASTM	A 36	
	Structurals	ASTM	A 36	
M-1.8	Shell Plate Thickness:			
	1st Course	mm	6 min.	
	2nd Course to 3rd Course	mm	5 min.	
M-1.9	Bottom Plate Thickness	mm	8 min.	
M-1.10	Bottom Plate Slope	mm/m	Per Specification	
M-1.11	Roof Plate Thickness	mm	5 min.	
M-1.12	Roof Plate Slope	degree	15	
M-1.13	Paint Specifications:			
	Shell Exterior		Per Specification	
	Shell Interior		Per Specification	
	Bottom Underside		Per Specification	
	Structurals		Per Specification	
M-1.14	Weld Examinations:			
	Shell	ASTM	Per Specification	
	Bottom Underside	ASTM	Per Specification	
	Roof	ASTM	Per Specification	
	Nozzles	ASTM	Per Specification	
M-1.15	Sounding Tape	m	10	
M-1.16	Level Switch		Included	

Name of Firm

Name & Signature of Representative

Designation



**M-1.0 FUEL OIL STORAGE TANK**

ITEM	DESCRIPTION	UNITS	NPC REQUIREMENT	CONTRACTOR'S DATA
<b>B. Palanan DPP and Jomalig DPP</b>				
M-1.1	Capacity (Nominal)	m <sup>3</sup>	60	
M-1.2	Design Code		API 650 or Approved Equivalent	
M-1.3	Quantity	sets	2	
M-1.4	Empty Weight	kg	By Contractor	
M-1.5	Operating Weight	kg	By Contractor	
M-1.6	Size (dia. X height)	m x m	3.6 x 6.1	
M-1.7	Materials of Construction:			
	Plate	ASTM	A 36	
	Structurals	ASTM	A 36	
M-1.8	Shell Plate Thickness:			
	1st Course	mm	6 min.	
	2nd Course to 3rd Course	mm	5 min.	
M-1.9	Bottom Plate Thickness	mm	8 min.	
M-1.10	Bottom Plate Slope	mm/m	Per Specification	
M-1.11	Roof Plate Thickness	mm	5 min.	
M-1.12	Roof Plate Slope	degree	15	
M-1.13	Paint Specifications:			
	Shell Exterior		Per Specification	
	Shell Interior		Per Specification	
	Bottom Underside		Per Specification	
	Structurals		Per Specification	
M-1.14	Weld Examinations:			
	Shell	ASTM	Per Specification	
	Bottom Underside	ASTM	Per Specification	
	Roof	ASTM	Per Specification	
	Nozzles	ASTM	Per Specification	
M-1.15	Sounding Tape	m	10	
M-1.16	Level Switch		Included	

Name of Firm

Name & Signature of Representative

Designation

**M-2.0 FUEL UNLOADING/TRANSFER PUMP**

ITEM	DESCRIPTION	UNITS	NPC REQUIREMENT	CONTRACTOR'S DATA
M-2.1.1	Pump (for each site)			
M-2.1a	Manufacturer		By Contractor	
M-2.1b	Place of Manufacture		By Contractor	
M-2.1c	Quantity	set	3	
M-2.1d	Type		Gear	
M-2.1e	Capacity	m <sup>3</sup> /h	10	
M-2.1f	Total Head	m	30	
M-2.1g	Speed	rpm	By Contractor	
M-2.1h	Efficiency	%	By Contractor	
M-2.1i	Power Required	kW	≤ 3.73 (5.0 HP)	
M-2.1j	Material:			
	Casing		Cast Iron	
	Gear		Ductile Iron	
	Shaft		H.Gr. Carbon Steel	
M-2.1k	Weight	kg	By Contractor	
M-12.2	Motor			
M-2.2a	Manufacturer		By Contractor	
M-2.2b	Place of Manufacture		By Contractor	
M-2.2c	Type & Protection		NEMA Standards	
M-2.2d	Insulation Class		Class F	
M-2.2e	Rating:			
	Voltage	V	240	
	Power Output	kW	≤ 3.73 (5.0 HP)	
	Phase		1	
	Frequency	Hz	60	
M-2.2f	Current at Rated Voltage:			
	Full Load	A	By Contractor	
	Locked Rotor	A	By Contractor	
M-2.2g	Speed	RPM	By Contractor	
M-2.2h	Weight	kg	By Contractor	

Name of Firm

Name & Signature of Representative

Designation

**M-3.0 FIRE EXTINGUISHERS**

ITEM	DESCRIPTION	UNITS	NPC REQUIREMENT	CONTRACTOR'S DATA
<b>M-3.1</b>	<b>Foam Wheeled Fire Extinguishers (for each site)</b>			
M-3.1.1	Manufacturer		By Contractor	
M-3.1.2	Type		AFFF, Wheeled	
M-3.1.3	Quantity (with container of foam additive)	sets	Three (3)	
M-3.1.4	Capacity	Liter	125	
M-3.1.5	Filled Weight	kg	By Contractor	
M-3.1.6	Height	mm	By Contractor	
M-3.1.7	Width	mm	By Contractor	
M-3.1.8	Depth	mm	By Contractor	
M-3.1.9	Discharge Flow	L/min.	By Contractor	
M-3.1.10	Working Pressure	kPa	By Contractor	
M-3.1.11	Foam discharge hose diameter	mm	25 min.	
M-3.1.12	Foam discharge hose length	m	15	
M-3.1.13	Volume of Nitrogen Tank	m <sup>3</sup>	By Contractor	
M-3.1.14	Approving Authority		UL/FM	
<b>M-3.2</b>	<b>Portable Fire Extinguishers (for each site)</b>			
M-3.2.1	Manufacturer		By Contractor	
M-3.2.2	Type		HCFC or Halotron I, Wall Hung	
M-3.2.3	Quantity	sets	Three (3)	
M-3.2.4	Capacity	kg	7.1	
M-3.2.5	Approving Authority		UL/FM	

Name of Firm

Name & Signature of Representative

Designation



TERMS OF REFERENCE

SUPPLY, DELIVERY, INSTALLATION AND TEST OF 1 x 35 KL  
AND 2 X 60 KL FOST FOR PATNANUNGAN DPP, PALANAN DPP  
AND JOMALIG DPP INCLUDING CONSTRUCTION OF  
ASSOCIATED FACILITIES UNDER PACKAGE 1

SECTION VI - BILL OF QUANTITIES

LuzP20Z1179Se

## SECTION VII

# BILL OF QUANTITIES



SECTION VII - BILL OF QUANTITIES

LuzP20Z1179S

**BILL OF QUANTITIES**

**SUPPLY, DELIVERY, INSTALLATION AND TEST OF 1X35 kV AND 2X60 kV FOST FOR PATNANUNGAN DPP, PALANAN DPP AND JOMALIG DPP INCLUDING CONSTRUCTION OF ASSOCIATED FACILITIES UNDER PACKAGE 1**

ITEM NO.	PARTICULARS	TOTAL AMOUNT (In Words)	TOTAL AMOUNT (In Figures)
<b>A.</b>	<b>Patnanungan DPP</b>		
1.0	Architectural Works		P
2.0	Civil Works		P
3.0	Mechanical Works		P
4.0	Electrical Works		P
<b>B.</b>	<b>Palanan DPP</b>		
1.0	Architectural Works		P
2.0	Civil Works		P
3.0	Mechanical Works		P
4.0	Electrical Works		P
<b>B.</b>	<b>Jomalig DPP</b>		
1.0	Architectural Works		P
2.0	Civil Works		P
3.0	Mechanical Works		P
4.0	Electrical Works		P
<b>TOTAL</b>		_____	P _____

**NOTE:** 1. Final delivery site of all equipment/materials shall be at the plant site stated above.

\_\_\_\_\_  
Name of Firm

\_\_\_\_\_  
Name and Signature of Authorized Representative

\_\_\_\_\_  
Designation



SECTION VII - BILL OF QUANTITIES

**ARCHITECTURAL WORKS**  
1x35 KL - PATNANUNGAN, QUEZON

Item No.	Description of Work or Materials	Work to Be Done	Reference	Unit	Estimated Quantity	Unit Price in Pesos (Words and Figures)	Total Amount (in Figures)
<b>AW PUMPHOUSE</b>							
<b>AW-1.0 WALL SYSTEM AND FINISHES</b>							
AW-1.1	150mm thick (6") CHB Wall Including mortars and reinforcing bars.	Furnish and Lay	Refer to NPC TS & Drawing	sq.m.	14.00	_____ (P _____)	_____ (P _____)
AW-1.2	Plastering: Plain cement plaster wall finish	Furnish and Apply	Refer to NPC TS & Drawing	sq.m.	31.00	_____ (P _____)	_____ (P _____)
AW-1.3	Pre-cast concrete Louvers	Furnish and Install	Refer to NPC TS & Drawing	sq.m.	1.00	_____ (P _____)	_____ (P _____)
<b>AW-2.0 FLOOR FINISHES</b>							
AW-2.1	Plain cement finish with floor hardener light traffic density	Furnish and Install	Refer to NPC TS & Drawing	sq.m.	3.00	_____ (P _____)	_____ (P _____)
<b>AW-3.0 FENESTRATION</b>							
AW-3.1	Doors: D - 1 (2100mm x 900mm) Flush Type Wooden Door Marine Plywood K.D. first group Lumber jamb, including heavy duty loose pin hinges, door knob/lockset weather proof and painting	Furnish and Install	Refer to NPC TS & Drawing	set	1.00	_____ (P _____)	_____ (P _____)
<b>AW-4.0 PAINTING</b>							
AW-4.1	All Concrete Surfaces	Furnish and Apply	Refer to NPC TS & Drawing	sq.m.	37.00	_____ (P _____)	_____ (P _____)
<b>SUB-TOTAL AMOUNT OF BID (ARCHI WORKS) PATNANUNGAN DPP</b>						_____ (P _____)	_____ (P _____)

\_\_\_\_\_  
Name of Firm

\_\_\_\_\_  
Name and Signature of Authorized Representative

\_\_\_\_\_  
Designation



SECTION VII - BILL OF QUANTITIES

**CIVIL WORKS**  
1x35 KL - PATNANUNGAN, QUEZON

Item No.	Description of Work or Materials	Work to Be Done	Reference	Unit	Estimated Quantity	Unit Price in Pesos (Words and Figures)	Total Amount (in Figures)
<b>CW-1.0</b>	<b>SITE DEVELOPMENT</b>						
CW-1.1	Grading Excavation	Excavate and Reuse	Refer to NPC TS & Drawing	cu.m.	8.00	_____ (P _____)	_____ (P _____)
CW-1.2	Grading Fill	Spread, Level & Compact	Refer to NPC TS & Drawing	cu.m.	12.00	_____ (P _____)	_____ (P _____)
CW-1.3	Clearing and Grubbing	Clear, Cut & Dispose	Refer to NPC TS & Drawing	lot.	1.00	_____ (P _____)	_____ (P _____)
<b>CW-2.0</b>	<b>FUEL OIL STORAGE TANK FOUNDATION</b>						
CW-2.1	Structural Excavation	Excavate, Stockpile & Dispose	Refer to NPC TS & Drawing	cu.m.	9.00	_____ (P _____)	_____ (P _____)
CW-2.2	Structural Fill	Furnish, Place, Spread & Compact	Refer to NPC TS & Drawing	cu.m.	6.00	_____ (P _____)	_____ (P _____)
CW-2.3	Sand Cushion	Furnish, Place, Spread & Compact	Refer to NPC TS & Drawing	cu.m.	0.50	_____ (P _____)	_____ (P _____)
CW-2.4	Crushed Stone	Furnish, Place, Spread & Compact	Refer to NPC TS & Drawing	cu.m.	5.00	_____ (P _____)	_____ (P _____)
CW-2.5	Concrete (20.70 MPa)	Furnish & Place	Refer to NPC TS & Drawing	cu.m.	6.00	_____ (P _____)	_____ (P _____)
CW-2.6	Reinforcing Steel Bars (Gr. 275)	Furnish, Schedule, Cut, Bend & Install	Refer to NPC TS & Drawing	kg.	480.00	_____ (P _____)	_____ (P _____)
CW-2.7	Concrete Epoxy Grout (2-component)	Furnish & Place	Refer to NPC TS & Drawing	li.	40.00	_____ (P _____)	_____ (P _____)
CW-2.8	2"Ø PVC Pipe	Furnish & Place	Refer to NPC TS & Drawing	lm.	2.00	_____ (P _____)	_____ (P _____)

\_\_\_\_\_  
Name of Firm

\_\_\_\_\_  
Name and Signature of Authorized Representative

\_\_\_\_\_  
Designation



SECTION VII - BILL OF QUANTITIES

**CIVIL WORKS**  
1x35 KL - PATNANUNGAN, QUEZON

Item No.	Description of Work or Materials	Work to Be Done	Reference	Unit	Estimated Quantity	Unit Price in Pesos (Words and Figures)	Total Amount (In Figures)
CW-2.9	High Density Polyethylene Liner 1.0 mm (40 mils) thick	Furnish & Place	Refer to NPC TS & Drawing	sq.m.	8.00	_____ (P _____)	_____ (P _____)
<b>CW-3.0</b>	<b>CONTAINMENT WALL</b>						
CW-3.1	Structural Excavation	Excavate, Stockpile & Dispose	Refer to NPC TS & Drawing	cu.m.	21.00	_____ (P _____)	_____ (P _____)
CW-3.2	Structural Backfill	Place, Spread & Compact	Refer to NPC TS & Drawing	cu.m.	11.00	_____ (P _____)	_____ (P _____)
CW-3.3	Concrete (20.70 MPa)	Furnish & Place	Refer to NPC TS & Drawing	cu.m.	12.00	_____ (P _____)	_____ (P _____)
CW-3.4	Reinforcing Steel Bars (Gr. 275)	Furnish, Schedule, Cut, Bend & Install	Refer to NPC TS & Drawing	kg.	700.00	_____ (P _____)	_____ (P _____)
CW-3.5	PVC Waterstop (6" x 3/16" Plain Dumbbell Type)	Furnish and Install	Refer to NPC TS & Drawing	lm.	25.00	_____ (P _____)	_____ (P _____)
CW-3.6	Ladder Rungs	Furnish, Bend and Install	Refer to NPC TS & Drawing	kgs.	32.00	_____ (P _____)	_____ (P _____)
<b>CW-4.0</b>	<b>DRAINAGE APPURTENANCES</b>						
CW-4.1	Drain Pit (DP)	Furnish and Construct	Refer to NPC TS & Drawing	pc.	1.00	_____ (P _____)	_____ (P _____)
CW-4.2	Valve Box (VB)	Furnish and Construct	Refer to NPC TS & Drawing	pc.	1.00	_____ (P _____)	_____ (P _____)

\_\_\_\_\_  
Name of Firm

\_\_\_\_\_  
Name and Signature of Authorized Representative

\_\_\_\_\_  
Designation





SECTION VII - BILL OF QUANTITIES

**CIVIL WORKS**  
1x35 KL - PATNANUNGAN, QUEZON

Item No.	Description of Work or Materials	Work to Be Done	Reference	Unit	Estimated Quantity	Unit Price in Pesos (Words and Figures)	Total Amount (In Figures)
<b>CW-5.0 PUMPHOUSE</b>							
CW-5.1	Structural Excavation	Excavate, Stockpile & Dispose	Refer to NPC TS & Drawing	cu.m	3.00	_____ (P _____)	_____ (P _____)
CW-5.2	Sand and Gravel Bedding	Furnish, Place and Level	Refer to NPC TS & Drawing	cu.m.	0.20	_____ (P _____)	_____ (P _____)
CW-5.3	Concrete, 20.70 Mpa	Furnish and Place	Refer to NPC TS & Drawing	cu.m.	2.40	_____ (P _____)	_____ (P _____)
CW-5.4	Reinforcing Steel Bars	Furnish, Cut, Bend and Install	Refer to NPC TS & Drawing	kgs.	268.00	_____ (P _____)	_____ (P _____)
CW-5.5	Application of concrete epoxy	Furnish and Apply	Refer to NPC TS & Drawing	gal.	1.00	_____ (P _____)	_____ (P _____)
<b>SUB-TOTAL AMOUNT OF BID (CIVIL WORKS) PATNANUNGAN DPP</b>						_____ (P _____)	_____ (P _____)

\_\_\_\_\_  
Name of Firm

\_\_\_\_\_  
Name and Signature of Authorized Representative

\_\_\_\_\_  
Designation



SECTION VII - BILL OF QUANTITIES

LuzP20Z1179Sa

**BILL OF QUANTITIES**

**1 X 35 KL FUEL OIL STORAGE TANK FOR PATNANUNGAN DPP**

Item No.	Description of Work or Materials	Work to be Done	Ref. Clause	Unit	Estimated Quantity	Unit Price in Pesos (Words and Figures)	Total Amount
<b>MW MECHANICAL WORKS</b>							
<b>MW-1.0 FUEL OIL STORAGE TANK</b>							
			<b>MW-3.0 &amp; Drawings</b>				
MW-1.1	Diesel Oil Storage Tank (35 cu. m.), 3.0 M Nominal Diameter x 5.4 M Height, complete with tank appurtenances, caged vertical ladder, hand railings, anchor bolts, level gauge, nozzles, associated piping & other tank appurtenances and accessories as described in the technical specifications and shown on bid drawing.	Supply, Fabrication Erection and Test		set	1	(P ) P	
MW-1.2	Tank Inspection, hydrotesting and liquid penetrant test	Conduct/Perform Testing		lot	1	(P ) P	
MW-1.3	Tank sandblasting and painting	Supply, Apply and Test		lot	1	(P ) P	
MW-1.4	Tank Calibration	Conduct/Perform Testing		lot	1	(P ) P	
MW-1.5	Fuel oil tank sounding tape, 10m long, aluminum alloy frame, stainless steel tape with brass dropper	Supply and Delivery		lot	1	(P ) P	
MW-1.6	Gate Valve, 65mm Ø, cast iron, flanged ends, OSY or rising stem, Class 150 (inlet outlet and spare)	Supply, Install and Test		sets	3	(P ) P	
MW-1.7	Gate Valve, drain line, 50 mm Ø, cast iron, flanged ends, OSY or rising stem, Class 150	Supply, Install and Test		sets	1	(P ) P	
MW-1.8	Butterfly Valve, 150mmØ, wafer type, cast iron body, stainless steel shaft-sleeve and disc, Class 150	Supply, Install and Test		set	1	(P ) P	
MW-1.9	Check Valve, 50 mm Ø, swing type, cast iron, flanged ends, Class 150	Supply, Install and Test		set	2	(P ) P	

\_\_\_\_\_  
Name of Firm

\_\_\_\_\_  
Name and Signature of Authorized Representative

\_\_\_\_\_  
Designation



SECTION VII - BILL OF QUANTITIES

LuzP2021179Se

**BILL OF QUANTITIES**

**1 X 35 KL FUEL OIL STORAGE TANK FOR PATNANUNGAN DPP**

Item No.	Description of Work or Materials	Work to be Done	Ref. Clause	Unit	Estimated Quantity	Unit Price in Pesos (Words and Figures)	Total Amount
MW-2.0	<b>FUEL OIL UNLOADING SYSTEM</b>		MW-4.0 & Drawings				
MW-2.1	Fuel Oil Unloading/Transfer Pump, 10m <sup>3</sup> /hr @ 30m head, 240V, 1-phase, 60 hertz, gear type, horizontal, complete with built-in relief valve, anchor bolts, control panel equipped ith circuit breaker and controls, monitoring and protection, cables safely laid in a conduit from the pumphouse to the power supply source and other accessories as described in the technical specifications and shown on the bid drawings.	Supply, Install and Test		set	1	(P _____) P _____	
2.2	Gate Valve, 65 mm Ø, OSY or rising stem, cast iron, flanged ends, Class 150	Supply, Install and Test		sets	5	(P _____) P _____	
2.3	Check Valve, 65 mm Ø, swing type, cast iron, flanged flanged ends, Class 150	Supply, Install and Test		sets	2	(P _____) P _____	
2.4	Check Valve, 50 mm Ø, swing type, cast iron, flanged flanged ends, Class 150	Supply, Install and Test		set	1	(P _____) P _____	
2.5	Globe Valve, 25mm Ø, cast bronze, flanged or screwed ends, OSY or rising stem, Class 150	Supply, Install and Test		sets	7	(P _____) P _____	
2.6	Simplex strainer, 65mm Ø, basket type, cast iron body, stainless steel element with magnet, flanged ends, 40 mesh minimum	Supply, Install and Test		sets	2	(P _____) P _____	
2.7	Flowmeter, 10 m <sup>3</sup> /hr rated flow, aluminum body, flanged ends, with LCD display, internal battery to last at least 5 years, ±0.5% accuracy, 0.02% repeatability, 150 lb, monitors accumulated total flow, resettable total flow and instantaneous flow, equipped with pulse generator or 4-20mA current output	Supply, Install and Test		set	1	(P _____) P _____	
2.8	Pressure gauge, 100 mm Ø dial gauge, buordon tube type, with dampener and isolation valve	Supply, Install and Test		sets	2	(P _____) P _____	
2.8	Spare parts for fuel oil transfer pump for one (1) year operation per Manufacturer's recommendation and as specified in the technical specifications to include the following: a) One (1) set of bearings for pump and motor b) One (1) set of bushings, wearing rings, packing and gaskets for the pump	Supply and Delivery		lot	1	(P _____) P _____	

\_\_\_\_\_  
 Name of Firm

\_\_\_\_\_  
 Name and Signature of Authorized Representative

\_\_\_\_\_  
 Designation



SECTION VII - BILL OF QUANTITIES

LuzP20Z1179Se

**BILL OF QUANTITIES**

**1 X 35 KL FUEL OIL STORAGE TANK FOR PATNANUNGAN DPP**

Item No.	Description of Work or Materials	Work to be Done	Ref. Clause	Unit	Estimated Quantity	Unit Price in Pesos (Words and Figures)	Total Amount
<b>MW-3.0 FUEL &amp; WASTE OIL TRANSFER PIPING SYSTEM</b>			<b>MW-4.0 &amp; Drawings</b>				
3.1	Fuel transfer pipe, 80mm Ø, ASTM A 53 Gr. B, seamless, schedule 40 and its associated fittings, pipe supports, gaskets, supports, flanges, bolts and other accessories	Supply, Excavate, Install, Test, & Backfill		lm	12	(P _____) P _____	
3.2	Fuel transfer pipe, 65mm Ø, ASTM A 53 Gr. B, seamless, schedule 40 and its associated fittings, pipe supports, gaskets, supports, flanges, bolts and other accessories	Supply, Excavate, Install, Test, & Backfill		lm	96	(P _____) P _____	
3.3	Fuel transfer pipe, 50mm Ø, ASTM A 53 Gr. B, seamless, schedule 40 and its associated fittings, pipe supports, gaskets, supports, flanges, bolts and other accessories	Supply, Excavate, Install, Test, & Backfill		lm	78	(P _____) P _____	
3.4	Fuel transfer pipe, 25mm Ø, ASTM A 53 Gr. B, seamless, schedule 40 and its associated fittings, pipe supports, gaskets, supports, flanges, bolts and other accessories	Supply, Install and Test		lm	18	(P _____) P _____	
3.3	Waste Oil Pipe, 160mm O.D. (150mm DN), unplasticized PVC, Sch 80 or class 150, conforming to ASTM D-1784, and its associated fittings, pipe supports and other accessories as described in the technical specifications or drawings.	Supply, Install and Test		lm	48	(P _____) P _____	
<b>4.0 FIRE EXTINGUISHERS</b>			<b>MW-6.0</b>				
4.1	Portable Fire Extinguisher, clean agent, (HCFC or Halotron I Type), 7.1 kg. (15.5 lbs), wall-hung type with bracket and accessories and UL/FM approved	Supply, Install Test		set	1	(P _____) P _____	
4.2	Wheeled Type Fire Extinguisher (Foam-AFFF) complete with self-contained cylinder mounted on frame with handle, floorstand and steel or rubberized wheels, 125 liters (33 gallons) capacity, associated valves, dial gauge indicator, nitrogen expellant tank for unit pressurization, 15 m long discharge hose of appropriate size fitted with couplings and foam nozzle assembly	Supply, Install Test		set	1	(P _____) P _____	

\_\_\_\_\_  
Name of Firm

\_\_\_\_\_  
Name and Signature of Authorized Representative

\_\_\_\_\_  
Designation



SECTION VII - BILL OF QUANTITIES

LuzP2021179Se

**BILL OF QUANTITIES**

**1 X 35 KL FUEL OIL STORAGE TANK FOR PATNANUNGAN DPP**

Item No.	Description of Work or Materials	Work to be Done	Ref. Clause	Unit	Estimated Quantity	Unit Price in Pesos (Words and Figures)	Total Amount
5.0	<b>MISCELLANEOUS</b>						
5.1	Tagging or Labaels for Equipment, Valve, Piping, Instruments and its fixing accessories as described in the bid documents	Supply, Install Test	GW-5.0	lot	1	(P ) P	
5.2	Painting for Fuel Oil Piping & Equipment, its associated valves, fittings, supports and other accessories including touch-up for	Supply, Install Test	GW-10.0	lot	1	(P ) P	
<b>TOTAL MECHANICAL WORKS</b>						(P ) P	

\_\_\_\_\_  
Name of Firm

\_\_\_\_\_  
Name and Signature of Authorized Representative

\_\_\_\_\_  
Designation



SECTION VII - BILL OF QUANTITIES

**SECTION VII - BILL OF QUANTITIES  
1 X 35 KL FOST FOR PATNANUNGAN DPP  
ELECTRICAL WORKS**

Item No.	Description of Work or Materials	Work to be Done	Ref.	Unit	Total Quantity	Unit Price in Pesos (Words and Figures)	Total Amount
<b>1.0</b>	<b>PUMP MOTOR CONTROL, PROTECTION AND MONITORING PANEL</b>						
a.	Local Control and Protection Panel including NEMA-1 Class Combination Motor Starter with 100AF/70AT MCCB, 1-Phase, Indicating Lights, etc. (to be installed in the Pump House)	Furnish, Install and Test	EW-TS & BD	set	1	(P _____)	P _____
b.	Remote Control Panel including Start/Stop Button, Indicating Lights, Instrumentation Cables, etc. (to be installed in the Engine Area)	Furnish, Install and Test	EW-TS & BD	set	1	(P _____)	P _____
c.	Monitoring Panel including Indicating Lights, Instrumentation Cables, etc. (to be installed in the Control Room)	Furnish, Install and Test	EW-TS & BD	set	1	(P _____)	P _____
<b>2.0</b>	<b>LIGHTING FIXTURES</b>						
a.	Fixture Type A (Portable Emergency Light, 2x2 W LED with built-in battery and battery charger)	Furnish, Install and Test	EW-TS & BD	set(s)	1	(P _____)	P _____

\_\_\_\_\_  
Name of Firm

\_\_\_\_\_  
Name and Signature of Authorized Representative

\_\_\_\_\_  
Designation



SECTION VII - BILL OF QUANTITIES

LuzP20Z1179Sa

**SECTION VII - BILL OF QUANTITIES  
1 X 35 KL FOST FOR PATNANUNGAN DPP  
ELECTRICAL WORKS**

Item No.	Description of Work or Materials	Work to be Done	Ref.	Unit	Total Quantity	Unit Price in Pesos (Words and Figures)	Total Amount
	b. Fixture Type B (1x9 W Compact LED Lighting Fixture)	Furnish, Install and Test	EW-TS & BD	set(s)	1	(P _____)	P _____
<b>3.0</b>	<b>OUTLETS AND SWITCHES INCLUDING PLATE COVER, FLUSH-MOUNTED, GROUNDING TYPE</b>						
	a. Convenience Outlet Duplex, with cover 16A, 230V, 1-phase	Furnish, Install and Test	EW-TS & BD	set(s)	1	(P _____)	P _____
	b. Outlet for Emergency Lighting Fixture Single Receptacle 16A, 230V, 1-phase	Furnish, Install and Test	EW-TS & BD	set(s)	1	(P _____)	P _____
	c. Single Pole Wall Switch, 10A, 230V	Furnish, Install and Test	EW-TS & BD	set(s)	1	(P _____)	P _____
	d. 50AF/15AT, 2-Pole, MCB, Enclosed Circuit Breaker (NEMA 1 Enclosure)	Furnish, Install and Test	EW-TS & BD	set(s)	1	(P _____)	P _____
<b>4.0</b>	<b>BUS CONDUCTOR AND INSULATED COPPER CONDUCTORS INCLUDING TERMINAL LUGS, CABLE TIES, IDENTIFICATION TAGS, ETC.</b>						
	a. 8.0 mm <sup>2</sup> , 600 V, Heat Resistant Thermoplastic, (THHN/THWN-2), Copper Conductor	Furnish, Lay and Test	EW-TS & BD	li.m	85	(P _____)	P _____
	a. 5.5 mm <sup>2</sup> , 600 V, Heat Resistant Thermoplastic, (THHN/THWN-2), Copper Conductor	Furnish, Lay and Test	EW-TS & BD	li.m	45	(P _____)	P _____

\_\_\_\_\_  
Name of Firm

\_\_\_\_\_  
Name and Signature of Authorized Representative

\_\_\_\_\_  
Designation



**SECTION VII - BILL OF QUANTITIES  
1 X 35 KL FOST FOR PATNANUNGAN DPP  
ELECTRICAL WORKS**

Item No.	Description of Work or Materials	Work to be Done	Ref.	Unit	Total Quantity	Unit Price in Pesos (Words and Figures)	Total Amount
b.	3.5 mm <sup>2</sup> , 600 V, Heat Resistant Thermoplastic, (THHN/THWN-2), Copper Conductor	Furnish, Lay and Test	EW-TS & BD	ll.m	20	_____ (P _____)	P _____
<b>5.0</b>	<b>EMBEDDED AND/OR NON-EMBEDDED CONDUITS INCLUDING BOXES, LOCKNUTS, ELBOWS, BOLTS AND OTHER FITTINGS</b>						
a.	25 mmØ uPVC	Furnish and Install	EW-TS & BD	ll.m	45	_____ (P _____)	P _____
b.	20 mmØ uPVC	Furnish and Install	EW-TS & BD	ll.m	10	_____ (P _____)	P _____
c.	Boxes, Locknuts, Elbows and Other Fittings	Furnish and Install	EW-TS & BD	lot	1	_____ (P _____)	P _____
<b>TOTAL ELECTRICAL WORKS</b>							P _____
							_____ (P _____)

\_\_\_\_\_  
Name of Firm

\_\_\_\_\_  
Name and Signature of Authorized Representative

\_\_\_\_\_  
Designation





SECTION VII - BILL OF QUANTITIES

**CIVIL WORKS**  
1x60 KL - PALANAN, ISABELA

Item No.	Description of Work or Materials	Work to Be Done	Reference	Unit	Estimated Quantity	Unit Price in Pesos (Words and Figures)	Total Amount (In Figures)
<b>CW-1.0 SITE DEVELOPMENT</b>							
CW-1.1	Grading Excavation	Excavate and Reuse	Refer to NPC TS & Drawing	cu.m.	12.00	_____ (P _____)	_____ (P _____)
CW-1.2	Grading Fill	Spread, Level & Compact	Refer to NPC TS & Drawing	cu.m.	18.00	_____ (P _____)	_____ (P _____)
CW-1.3	Clearing and Grubbing	Clear, Cut & Dispose	Refer to NPC TS & Drawing	lot.	1.00	_____ (P _____)	_____ (P _____)
<b>CW-2.0 FUEL OIL STORAGE TANK FOUNDATION</b>							
CW-2.1	Structural Excavation	Excavate, Stockpile & Dispose	Refer to NPC TS & Drawing	cu.m.	12.50	_____ (P _____)	_____ (P _____)
CW-2.2	Structural Fill	Furnish, Place, Spread & Compact	Refer to NPC TS & Drawing	cu.m.	8.00	_____ (P _____)	_____ (P _____)
CW-2.3	Sand Cushion	Furnish, Place, Spread & Compact	Refer to NPC TS & Drawing	cu.m.	0.50	_____ (P _____)	_____ (P _____)
CW-2.4	Crushed Stone	Furnish, Place, Spread & Compact	Refer to NPC TS & Drawing	cu.m.	7.50	_____ (P _____)	_____ (P _____)
CW-2.5	Concrete (20.70 MPa)	Furnish & Place	Refer to NPC TS & Drawing	cu.m.	8.00	_____ (P _____)	_____ (P _____)
CW-2.6	Reinforcing Steel Bars (Gr. 275)	Furnish, Schedule, Cut, Bend & Install	Refer to NPC TS & Drawing	kg.	625.00	_____ (P _____)	_____ (P _____)
CW-2.7	Concrete Epoxy Grout (2-component)	Furnish & Place	Refer to NPC TS & Drawing	ll.	40.00	_____ (P _____)	_____ (P _____)

\_\_\_\_\_  
Name of Firm

\_\_\_\_\_  
Name and Signature of Authorized Representative

\_\_\_\_\_  
Designation



SECTION VII - BILL OF QUANTITIES

**CIVIL WORKS**  
1x60 KL - PALANAN, ISABELA

Item No.	Description of Work or Materials	Work to Be Done	Reference	Unit	Estimated Quantity	Unit Price in Pesos (Words and Figures)	Total Amount (In Figures)
CW-2.8	2"Ø PVC Pipe	Furnish & Place	Refer to NPC TS & Drawing	lm.	2.00	_____ (P_____)	_____ (P_____)
CW-2.9	High Density Polyethylene Liner 1.0 mm (40 mils) thick	Furnish & Place	Refer to NPC TS & Drawing	sq.m.	11.00	_____ (P_____)	_____ (P_____)
<b>CW-3.0</b>	<b>CONTAINMENT WALL</b>						
CW-3.1	Structural Excavation	Excavate, Stockpile & Dispose	Refer to NPC TS & Drawing	cu.m.	28.00	_____ (P_____)	_____ (P_____)
CW-3.2	Structural Backfill	Place, Spread & Compact	Refer to NPC TS & Drawing	cu.m.	17.00	_____ (P_____)	_____ (P_____)
CW-3.3	Concrete (20.70 MPa)	Furnish & Place	Refer to NPC TS & Drawing	cu.m.	16.00	_____ (P_____)	_____ (P_____)
CW-3.4	Reinforcing Steel Bars (Gr. 275)	Furnish, Schedule, Cut, Bend & Install	Refer to NPC TS & Drawing	kg.	850.00	_____ (P_____)	_____ (P_____)
CW-3.5	PVC Waterstop (6" x 3/16" Plain Dumbbell Type)	Furnish and Install	Refer to NPC TS & Drawing	lm.	31.00	_____ (P_____)	_____ (P_____)
CW-3.6	Ladder Rungs	Furnish, Bend and Install	Refer to NPC TS & Drawing	kgs.	39.00	_____ (P_____)	_____ (P_____)
<b>CW-4.0</b>	<b>DRAINAGE APPURTENANCES</b>						
CW-4.1	Drain Pit (DP)	Furnish and Construct	Refer to NPC TS & Drawing	pc.	1.00	_____ (P_____)	_____ (P_____)
CW-4.2	Valve Box (VB)	Furnish and Construct	Refer to NPC TS & Drawing	pc.	1.00	_____ (P_____)	_____ (P_____)

\_\_\_\_\_  
Name of Firm

\_\_\_\_\_  
Name and Signature of Authorized Representative

\_\_\_\_\_  
Designation



SECTION VII - BILL OF QUANTITIES

**CIVIL WORKS**  
1x60 KL - PALANAN, ISABELA

Item No.	Description of Work or Materials	Work to Be Done	Reference	Unit	Estimated Quantity	Unit Price in Pesos (Words and Figures)	Total Amount (In Figures)
CW-4.3	Oil Water Separator (OWS) (including 100mm Ø PVC outlet pipe)	Furnish and Construct	Refer to NPC TS & Drawing	pc.	1.00	_____ (P _____)	_____ (P _____)
CW-4.4	Drainage Canal	Furnish and Construct	Refer to NPC TS & Drawing	l.m.	9.00	_____ (P _____)	_____ (P _____)
<b>CW-5.0</b>	<b>DEMOLITION WORKS</b>						
CW-5.1	Existing 4KL FOST (foundation, drainage and containment wall, etc)	Transfer, Excavate Demolish & Dispose	Refer to NPC TS & Drawing	lot.	1.00	_____ (P _____)	_____ (P _____)
CW-5.2	Concrete Pavement	Demolish & Dispose	Refer to NPC TS & Drawing	lot.	1.00	_____ (P _____)	_____ (P _____)
CW-5.3	Drainage Canal	Demolish & Dispose	Refer to NPC TS & Drawing	lot.	1.00	_____ (P _____)	_____ (P _____)
<b>SUB-TOTAL AMOUNT OF BID (CIVIL WORKS) PALANAN DPP</b>						_____ (P _____)	_____ (P _____)

\_\_\_\_\_  
Name of Firm

\_\_\_\_\_  
Name and Signature of Authorized Representative

\_\_\_\_\_  
Designation



SECTION VII - BILL OF QUANTITIES

LuzP20Z1179Se

**BILL OF QUANTITIES**

**1 X 60 KL FUEL OIL STORAGE TANK FOR PALANAN DPP**

Item No.	Description of Work or Materials	Work to be Done	Ref. Clause	Unit	Estimated Quantity	Unit Price in Pesos (Words and Figures)	Total Amount
<b>MW MECHANICAL WORKS</b>							
<b>MW-1.0 FUEL OIL STORAGE TANK</b>							
			<b>MW-3.0 &amp; Drawings</b>				
MW-1.1	Diesel Oil Storage Tank (60 cu. m.), 3.6 M Nominal Diameter x 6.1 M Height, complete with tank appurtenances, caged vertical ladder, hand railings, anchor bolts, level gauge, nozzles, associated piping & other tank appurtenances and accessories as described in the technical specifications and shown on bid drawing.	Supply, Fabrication Erection and Test		set	1	(P ) P	
MW-1.2	Tank Inspection, hydrotesting and liquid penetrant test	Conduct/Perform Testing		lot	1	(P ) P	
MW-1.3	Tank sandblasting and painting	Supply, Apply and Test		lot	1	(P ) P	
MW-1.4	Tank Calibration	Conduct/Perform Testing		lot	1	(P ) P	
MW-1.5	Fuel oil tank sounding tape, 10m long, aluminum alloy frame, stainless steel tape with brass dropper	Supply and Delivery		lot	1	(P ) P	
MW-1.6	Gate Valve, 65mm Ø, cast iron, flanged ends, OSY or rising stem, Class 150 (inlet outlet and spare)	Supply, Install and Test		sets	3	(P ) P	
MW-1.7	Gate Valve, drain line, 50 mm Ø, cast iron, flanged ends, OSY or rising stem, Class 150	Supply, Install and Test		sets	1	(P ) P	
MW-1.8	Butterfly Valve, 150mmØ, wafer type, cast iron body, stainless steel shaft-sleeve and disc, Class 150	Supply, Install and Test		set	1	(P ) P	
MW-1.9	Check Valve, 50 mm Ø, swing type, cast iron, flanged ends, Class 150	Supply, Install and Test		set	2	(P ) P	
1.1	Gate Valve, 25 mm Ø, cast iron, flanged ends, OSY or rising stem, Class 150	Supply, Install and Test		set	6	(P ) P	

\_\_\_\_\_  
Name of Firm

\_\_\_\_\_  
Name and Signature of Authorized Representative

\_\_\_\_\_  
Designation



SECTION VII - BILL OF QUANTITIES

LuzP20Z11795e

**BILL OF QUANTITIES**  
**1 X 60 KL FUEL OIL STORAGE TANK FOR PALANAN DPP**

Item No.	Description of Work or Materials	Work to be Done	Ref. Clause	Unit	Estimated Quantity	Unit Price in Pesos (Words and Figures)	Total Amount
<b>MW-2.0 FUEL OIL UNLOADING SYSTEM</b>							
MW-2.1	Fuel Oil Unloading/Transfer Pump, 10m <sup>3</sup> /hr @ 30m head, 240V, 1-phase, 60 hertz, gear type, horizontal, complete with built-in relief valve, anchor bolts, control panel equipped ith circuit breaker and controls, monitoring and protection, cables safely laid in a conduit from the pumphouse to the power supply source and other accessories as described in the technical specifications and shown on the bid drawings.	Supply, Install and Test	MW-4.0 & Drawings	set	1	(P _____) P _____	
2.2	Gate Valve, 65 mm Ø, OSY or rising stem, cast iron, flanged ends, Class 150	Supply, Install and Test		sets	8	(P _____) P _____	
2.3	Check Valve, 65 mm Ø, swing type, cast iron, flanged flanged ends, Class 150	Supply, Install and Test		sets	2	(P _____) P _____	
2.4	Globe Valve, 25mm Ø, cast bronze, flanged or screwed ends, OSY or rising stem, Class 150	Supply, Install and Test		sets	3	(P _____) P _____	
2.5	Simplex strainer, 65mm Ø, basket type, cast iron body, stainless steel element with magnet, flanged ends, 40 mesh minimum	Supply, Install and Test		sets	2	(P _____) P _____	
2.6	Flowmeter, 10 m <sup>3</sup> /hr rated flow, aluminum body, flanged ends, with LCD display, internal battery to last at least 5 years, ±0.5% accuracy, 0.02% repeatability, 150 lb, monitors accumulated total flow, resettable total flow and instantaneous flow, equipped with pulse generator or 4-20mA current output	Supply, Install and Test		set	1	(P _____) P _____	
2.7	Pressure gauge, 100 mm Ø dial gauge, buordon tube type, with dampener and isolation valve	Supply, Install and Test		sets	2	(P _____) P _____	
2.8	Spare parts for fuel oil transfer pump for one (1) year operation per Manufacturer's recommendation and as specified in the technical specifications to include the following: a) One (1) set of bearings for pump and motor b) One (1) set of bushings, wearing rings, packing and gaskets for the pump	Supply and Delivery		lot	1	(P _____) P _____	

\_\_\_\_\_  
 Name of Firm

\_\_\_\_\_  
 Name and Signature of Authorized Representative

\_\_\_\_\_  
 Designation



SECTION VII - BILL OF QUANTITIES

LuzP20Z1179Se

**BILL OF QUANTITIES**

**1 X 60 KL FUEL OIL STORAGE TANK FOR PALANAN DPP**

Item No.	Description of Work or Materials	Work to be Done	Ref. Clause	Unit	Estimated Quantity	Unit Price in Pesos (Words and Figures)	Total Amount
<b>MW-3.0 FUEL &amp; WASTE OIL TRANSFER PIPING SYSTEM</b>							
			<b>MW-4.0 &amp; Drawings</b>				
3.1	Fuel transfer pipe, 80mm Ø, ASTM A 53 Gr. B, seamless, schedule 40 and its associated fittings, pipe supports, gaskets, supports, flanges, bolts and other accessories	Supply, Excavate, Install, Test, & Backfill		lm	12	(P ) P	
3.2	Fuel transfer pipe, 65mm Ø, ASTM A 53 Gr. B, seamless, schedule 40 and its associated fittings, pipe supports, gaskets, supports, flanges, bolts and other accessories	Supply, Excavate, Install, Test, & Backfill		lm	102	(P ) P	
3.3	Fuel transfer pipe, 25mm Ø, ASTM A 53 Gr. B, seamless, schedule 40 and its associated fittings, pipe supports, gaskets, supports, flanges, bolts and other accessories	Supply, Install and Test		lm	18	(P ) P	
3.4	Waste Oil Pipe, 160mm O.D. (150mm DN), unplasticized PVC, Sch 80 or class 150, conforming to ASTM D-1784, and its associated fittings, pipe supports and other accessories as described in the technical specifications or drawings.	Supply, Install and Test		lm	6	(P ) P	
<b>4.0 FIRE EXTINGUISHERS</b>							
			<b>MW-6.0</b>				
4.1	Portable Fire Extinguisher, clean agent, (HCFC or Halotron I Type), 7.1 kg. (15.5 lbs), wall-hung type with bracket and accessories and UL/FM approved	Supply, Install Test		set	1	(P ) P	
4.2	Wheeled Type Fire Extinguisher (Foam-AFFF) complete with self-contained cylinder mounted on frame with handle, floorstand and steel or rubberized wheels, 125 liters (33 gallons) capacity, associated valves, dial gauge indicator, nitrogen expellant tank for unit pressurization, 15 m long discharge hose of appropriate size fitted with couplings and foam nozzle assembly	Supply, Install Test		set	1	(P ) P	

Name of Firm  
 NATIONAL POWER CORPORATION

Name and Signature of Authorized Representative



Designation

SECTION VII - BILL OF QUANTITIES

LuzP20Z1179Se

**BILL OF QUANTITIES**  
**1 X 60 KL FUEL OIL STORAGE TANK FOR PALANAN DPP**

Item No.	Description of Work or Materials	Work to be Done	Ref. Clause	Unit	Estimated Quantity	Unit Price in Pesos (Words and Figures)	Total Amount
<b>5.0</b>	<b>MISCELLANEOUS</b>						
5.1	Tagging or Labaels for Equipment, Valve, Piping, Instruments and its fixing accessories as described in the bid documents	Supply, Install Test	GW-5.0	lot	1	(P _____ ) P _____	
5.2	Painting for Fuel Oil Piping & Equipment, its associated valves, fittings, supports and other accessories including touch-up for	Supply, Install Test	GW-10.0	lot	1	(P _____ ) P _____	
<b>TOTAL MECHANICAL WORKS</b>						(P _____ ) P _____	

\_\_\_\_\_  
Name of Firm

\_\_\_\_\_  
Name and Signature of Authorized Representative

\_\_\_\_\_  
Designation



SECTION VII - BILL OF QUANTITIES

**SECTION VII - BILL OF QUANTITIES**  
**1 X 60 KL FOST FOR PALANAN DPP**  
**ELECTRICAL WORKS**

Item No.	Description of Work or Materials	Work to be Done	Ref.	Unit	Total Quantity	Unit Price in Pesos (Words and Figures)	Total Amount
<b>1.0</b>	<b>PUMP MOTOR CONTROL, PROTECTION AND MONITORING PANEL</b>						
a.	Local Control and Protection Panel including NEMA-1 Class Combination Motor Starter with 100AF/70AT MCCB, 1-Phase, Indicating Lights, etc. (to be installed in the Pump House)	Furnish, Install and Test	EW-TS & BD	set	1	_____ P _____ (P _____)	_____ P _____
b.	Remote Control Panel including Start/Stop Button, Indicating Lights, Instrumentation Cables, etc. (to be installed in the Engine Area)	Furnish, Install and Test	EW-TS & BD	set	1	_____ P _____ (P _____)	_____ P _____
c.	Monitoring Panel including Indicating Lights, Instrumentation Cables, etc. (to be installed in the Control Room)	Furnish, Install and Test	EW-TS & BD	set	1	_____ P _____ (P _____)	_____ P _____
<b>2.0</b>	<b>LIGHTING FIXTURES</b>						
a.	Fixture Type A (Portable Emergency Light, 2x2 W LED with built-in battery and battery charger)	Furnish, Install and Test	EW-TS & BD	set(s)	1	_____ P _____ (P _____)	_____ P _____

\_\_\_\_\_  
Name of Firm

\_\_\_\_\_  
Name and Signature of Authorized Representative

\_\_\_\_\_  
Designation





**SECTION VII - BILL OF QUANTITIES  
1 X 60 KL FOST FOR PALANAN DPP  
ELECTRICAL WORKS**

Item No.	Description of Work or Materials	Work to be Done	Ref.	Unit	Total Quantity	Unit Price in Pesos (Words and Figures)	Total Amount
	b. Fixture Type B (1x9 W Compact LED Lighting Fixture)	Furnish, Install and Test	EW-TS & BD	set(s)	2	(P _____)	P _____
<b>3.0</b>	<b>OUTLETS AND SWITCHES INCLUDING PLATE COVER, FLUSH-MOUNTED, GROUNDING TYPE</b>						
	a. Convenience Outlet Duplex, with cover 16A, 230V, 1-phase	Furnish, Install and Test	EW-TS & BD	set(s)	1	(P _____)	P _____
	b. Outlet for Emergency Lighting Fixture Single Receptacle 16A, 230V, 1-phase	Furnish, Install and Test	EW-TS & BD	set(s)	1	(P _____)	P _____
	c. Single Pole Wall Switch, 10A, 230V	Furnish, Install and Test	EW-TS & BD	set(s)	1	(P _____)	P _____
	d. 50AF/15AT, 2-Pole, MCB, Enclosed Circuit Breaker (NEMA 1 Enclosure)	Furnish, Install and Test	EW-TS & BD	set(s)	1	(P _____)	P _____
<b>4.0</b>	<b>BUS CONDUCTOR AND INSULATED COPPER CONDUCTORS INCLUDING TERMINAL LUGS, CABLE TIES, IDENTIFICATION TAGS, ETC.</b>						
	a. 8.0 mm <sup>2</sup> , 600 V, Heat Resistant Thermoplastic, (THHN/THWN-2), Copper Conductor	Furnish, Lay and Test	EW-TS & BD	ll.m	100	(P _____)	P _____
	a. 5.5 mm <sup>2</sup> , 600 V, Heat Resistant Thermoplastic, (THHN/THWN-2), Copper Conductor	Furnish, Lay and Test	EW-TS & BD	ll.m	50	(P _____)	P _____

\_\_\_\_\_  
Name of Firm

\_\_\_\_\_  
Name and Signature of Authorized Representative

\_\_\_\_\_  
Designation



SECTION VII - BILL OF QUANTITIES

**SECTION VII - BILL OF QUANTITIES  
1 X 60 KL FOST FOR PALANAN DPP  
ELECTRICAL WORKS**

Item No.	Description of Work or Materials	Work to be Done	Ref.	Unit	Total Quantity	Unit Price in Pesos (Words and Figures)	Total Amount
	b. 3.5 mm <sup>2</sup> , 600 V, Heat Resistant Thermoplastic, (THHN/THWN-2), Copper Conductor	Furnish, Lay and Test	EW-TS & BD	li.m	25	(P _____)	P _____
<b>5.0</b>	<b>EMBEDDED AND/OR NON-EMBEDDED CONDUITS INCLUDING BOXES, LOCKNUTS, ELBOWS, BOLTS AND OTHER FITTINGS</b>						
	a. 25 mmØ uPVC	Furnish and Install	EW-TS & BD	li.m	50	(P _____)	P _____
	b. 20 mmØ uPVC	Furnish and Install	EW-TS & BD	li.m	10	(P _____)	P _____
	c. Boxes, Locknuts, Elbows and Other Fittings	Furnish and Install	EW-TS & BD	lot	1	(P _____)	P _____
<b>6.0</b>	<b>DISMANTLING OF, LIGHTING FIXTURE, CONVENIENCE OUTLET, CABLES AND CONDUITS FOR PALANAN DPP</b>			lot	1	(P _____)	P _____
<b>TOTAL ELECTRICAL WORKS</b>							P _____ (P _____)

\_\_\_\_\_  
Name of Firm

\_\_\_\_\_  
Name and Signature of Authorized Representative

\_\_\_\_\_  
Designation



SECTION VII - BILL OF QUANTITIES

**ARCHITECTURAL WORKS**  
1x60 KL - JOMALIG, QUEZON

Item No.	Description of Work or Materials	Work to Be Done	Reference	Unit	Estimated Quantity	Unit Price in Pesos (Words and Figures)	Total Amount (in Figures)
<b>AW PUMPHOUSE</b>							
<b>AW-1.0 WALL SYSTEM AND FINISHES</b>							
AW-1.1	150mm thick (6") CHB Wall Including mortars and reinforcing bars.	Furnish and Lay	Refer to NPC TS & Drawing	sq.m.	14.00	_____ (P _____)	_____ (P _____)
AW-1.2	Plastering: Plain cement plaster wall finish	Furnish and Apply	Refer to NPC TS & Drawing	sq.m.	31.00	_____ (P _____)	_____ (P _____)
AW-1.3	Pre-cast concrete Louvers	Furnish and Install	Refer to NPC TS & Drawing	sq.m.	1.00	_____ (P _____)	_____ (P _____)
<b>AW-2.0 FLOOR FINISHES</b>							
AW-2.1	Plain cement finish with floor hardener light traffic density	Furnish and Install	Refer to NPC TS & Drawing	sq.m.	3.00	_____ (P _____)	_____ (P _____)
<b>AW-3.0 FENESTRATION</b>							
AW-3.1	Doors: D - 1 (2100mm x 900mm) Flush Type Wooden Door Marine Plywood K.D. first group Lumber jamb, including heavy duty loose pin hinges, door knob/lockset weather proof and painting	Furnish and Install	Refer to NPC TS & Drawing	set	1.00	_____ (P _____)	_____ (P _____)
<b>AW-4.0 PAINTING</b>							
AW-4.1	All Concrete Surfaces	Furnish and Apply	Refer to NPC TS & Drawing	sq.m.	37.00	_____ (P _____)	_____ (P _____)
<b>SUB-TOTAL AMOUNT OF BID (ARCHI WORKS) JOMALIG DPP</b>						_____ (P _____)	_____ (P _____)

\_\_\_\_\_  
Name of Firm

\_\_\_\_\_  
Name and Signature of Authorized Representative

\_\_\_\_\_  
Designation



SECTION VII - BILL OF QUANTITIES

**CIVIL WORKS**  
1x60 KL - JOMALIG, QUEZON

Item No.	Description of Work or Materials	Work to Be Done	Reference	Unit	Estimated Quantity	Unit Price in Pesos (Words and Figures)	Total Amount (In Figures)
<b>CW-1.0 SITE DEVELOPMENT</b>							
CW-1.1	Grading Excavation	Excavate and Reuse	Refer to NPC TS & Drawing	cu.m.	12.50	_____ (P _____)	_____ (P _____)
CW-1.2	Grading Fill	Spread, Level & Compact	Refer to NPC TS & Drawing	cu.m.	18.50	_____ (P _____)	_____ (P _____)
CW-1.3	Clearing and Grubbing	Clear, Cut & Dispose	Refer to NPC TS & Drawing	lot.	1.00	_____ (P _____)	_____ (P _____)
<b>CW-2.0 FUEL OIL STORAGE TANK FOUNDATION</b>							
CW-2.1	Structural Excavation	Excavate, Stockpile & Dispose	Refer to NPC TS & Drawing	cu.m.	12.50	_____ (P _____)	_____ (P _____)
CW-2.2	Structural Fill	Furnish, Place, Spread & Compact	Refer to NPC TS & Drawing	cu.m.	6.00	_____ (P _____)	_____ (P _____)
CW-2.3	Sand Cushion	Furnish, Place, Spread & Compact	Refer to NPC TS & Drawing	cu.m.	0.50	_____ (P _____)	_____ (P _____)
CW-2.4	Crushed Stone	Furnish, Place, Spread & Compact	Refer to NPC TS & Drawing	cu.m.	7.50	_____ (P _____)	_____ (P _____)
CW-2.5	Concrete (20.70 MPa)	Furnish & Place	Refer to NPC TS & Drawing	cu.m.	8.00	_____ (P _____)	_____ (P _____)
CW-2.6	Reinforcing Steel Bars (Gr. 275)	Furnish, Schedule, Cut, Bend & Install	Refer to NPC TS & Drawing	kg.	625.00	_____ (P _____)	_____ (P _____)
CW-2.7	Concrete Epoxy Grout (2-component)	Furnish & Place	Refer to NPC TS & Drawing	li.	40.00	_____ (P _____)	_____ (P _____)
CW-2.8	2"Ø PVC Pipe	Furnish & Place	Refer to NPC TS & Drawing	lm.	2.00	_____ (P _____)	_____ (P _____)

\_\_\_\_\_  
Name of Firm

\_\_\_\_\_  
Name and Signature of Authorized Representative

\_\_\_\_\_  
Designation



SECTION VII - BILL OF QUANTITIES

**CIVIL WORKS**  
1x60 KL - JOMALIG, QUEZON

Item No.	Description of Work or Materials	Work to Be Done	Reference	Unit	Estimated Quantity	Unit Price in Pesos (Words and Figures)	Total Amount (In Figures)
CW-2.9	High Density Polyethylene Liner 1.0 mm (40 mils) thick	Furnish & Place	Refer to NPC TS & Drawing	sq.m.	11.00	(P )	(P )
<b>CW-3.0</b>	<b>CONTAINMENT WALL</b>						
CW-3.1	Structural Excavation	Excavate, Stockpile & Dispose	Refer to NPC TS & Drawing	cu.m.	28.00	(P )	(P )
CW-3.2	Structural Backfill	Place, Spread & Compact	Refer to NPC TS & Drawing	cu.m.	17.00	(P )	(P )
CW-3.3	Concrete (20.70 MPa)	Furnish & Place	Refer to NPC TS & Drawing	cu.m.	16.00	(P )	(P )
CW-3.4	Reinforcing Steel Bars (Gr. 275)	Furnish, Schedule, Cut, Bend & Install	Refer to NPC TS & Drawing	kg.	850.00	(P )	(P )
CW-3.5	PVC Waterstop (6" x 3/16" Plain Dumbbell Type)	Furnish and Install	Refer to NPC TS & Drawing	lm.	31.00	(P )	(P )
CW-3.6	Ladder Rungs	Furnish, Bend and Install	Refer to NPC TS & Drawing	kgs.	39.00	(P )	(P )
<b>CW-4.0</b>	<b>DRAINAGE APPURTENANCES</b>						
CW-4.1	Drain Pit (DP)	Furnish and Construct	Refer to NPC TS & Drawing	pc.	1.00	(P )	(P )
CW-4.2	Valve Box (VB)	Furnish and Construct	Refer to NPC TS & Drawing	pc.	1.00	(P )	(P )
CW-4.2	Oil-Water Separator (OWS) (including 100mm Ø PVC outlet pipe)	Furnish and Construct	Refer to NPC TS & Drawing	pc.	1.00	(P )	(P )

Name of Firm

Name and Signature of Authorized Representative

Designation



SECTION VII - BILL OF QUANTITIES

**CIVIL WORKS**  
1x60 KL - JOMALIG, QUEZON

Item No.	Description of Work or Materials	Work to Be Done	Reference	Unit	Estimated Quantity	Unit Price in Pesos (Words and Figures)	Total Amount (In Figures)
<b>CW-5.0</b>	<b>PUMPHOUSE</b>						
CW-5.1	Structural Excavation	Excavate, Stockpile & Dispose	Refer to NPC TS & Drawing	cu.m	3.00	_____ (P _____)	_____ (P _____)
CW-5.2	Sand and Gravel Bedding	Furnish, Place and Level	Refer to NPC TS & Drawing	cu.m.	0.20	_____ (P _____)	_____ (P _____)
CW-5.3	Concrete, 20.70 Mpa	Furnish and Place	Refer to NPC TS & Drawing	cu.m.	2.40	_____ (P _____)	_____ (P _____)
CW-5.4	Reinforcing Steel Bars	Furnish, Cut, Bend and Install	Refer to NPC TS & Drawing	kgs.	268.00	_____ (P _____)	_____ (P _____)
CW-5.5	Application of concrete epoxy	Furnish and Apply	Refer to NPC TS & Drawing	gal.	1.00	_____ (P _____)	_____ (P _____)
<b>SUB-TOTAL AMOUNT OF BID (CIVIL WORKS) JOMALIG DPP</b>						_____ (P _____)	_____ (P _____)

\_\_\_\_\_  
Name of Firm

\_\_\_\_\_  
Name and Signature of Authorized Representative

\_\_\_\_\_  
Designation



SECTION VII - BILL OF QUANTITIES

LuzP20211795a

**BILL OF QUANTITIES**

**1 X 60 KL FUEL OIL STORAGE TANK FOR JOMALIG DPP**

Item No.	Description of Work or Materials	Work to be Done	Ref. Clause	Unit	Estimated Quantity	Unit Price in Pesos (Words and Figures)	Total Amount
<b>MW</b>	<b>MECHANICAL WORKS</b>						
<b>MW-1.0</b>	<b>FUEL OIL STORAGE TANK</b>		<b>MW-3.0 &amp; Drawings</b>				
MW-1.1	Diesel Oil Storage Tank (60 cu. m.), 3.6 M Nominal Diameter x 6.1 M Height, complete with tank appurtenances, caged vertical ladder, hand railings, anchor bolts, level gauge, nozzles, associated piping & other tank appurtenances and accessories as described in the technical specifications and shown on bid drawing.	Supply, Fabrication Erection and Test		set	1	(P _____) P _____	
MW-1.2	Tank inspection, hydrotesting and liquid penetrant test	Conduct/Perform Testing		lot	1	(P _____) P _____	
MW-1.3	Tank sandblasting and painting	Supply, Apply and Test		lot	1	(P _____) P _____	
MW-1.4	Tank Calibration	Conduct/Perform Testing		lot	1	(P _____) P _____	
MW-1.5	Fuel oil tank sounding tape, 10m long, aluminum alloy frame, stainless steel tape with brass dropper	Supply and Delivery		lot	1	(P _____) P _____	
MW-1.6	Gate Valve, 65mm Ø, cast iron, flanged ends, OSY or rising stem, Class 150 (inlet outlet and spare)	Supply, Install and Test		sets	3	(P _____) P _____	
MW-1.7	Gate Valve, drain line, 50 mm Ø, cast iron, flanged ends, OSY or rising stem, Class 150	Supply, Install and Test		sets	1	(P _____) P _____	
MW-1.8	Butterfly Valve, 150mmØ, wafer type, cast iron body, stainless steel shaft-sleeve and disc, Class 150	Supply, Install and Test		set	1	(P _____) P _____	
MW-1.9	Check Valve, 65 mm Ø, swing type, cast iron, flanged ends, Class 150	Supply, Install and Test		set	3	(P _____) P _____	

\_\_\_\_\_  
Name of Firm

\_\_\_\_\_  
Name and Signature of Authorized Representative

\_\_\_\_\_  
Designation

SECTION VII - BILL OF QUANTITIES

LuzP2021179Se

**BILL OF QUANTITIES**

**1 X 60 KL FUEL OIL STORAGE TANK FOR JOMALIG DPP**

Item No.	Description of Work or Materials	Work to be Done	Ref. Clause	Unit	Estimated Quantity	Unit Price in Pesos (Words and Figures)	Total Amount
<b>MW-2.0 FUEL OIL UNLOADING SYSTEM</b>							
			<b>MW-4.0 &amp; Drawings</b>				
MW-2.1	Fuel Oil Unloading/Transfer Pump, 10m <sup>3</sup> /hr @ 30m head, 240V, 1-phase, 60 hertz, gear type, horizontal, complete with built-in relief valve, anchor bolts, control panel equipped ith circuit breaker and controls, monitoring and protection, cables safely laid in a conduit from the pumphouse to the power supply source and other accessories as described in the technical specifications and shown on the bid drawings.	Supply, Install and Test		set	1	(P _____ ) P _____	
2.2	Gate Valve, 65 mm Ø, OSY or rising stem, cast iron, flanged ends, Class 150	Supply, Install and Test		sets	8	(P _____ ) P _____	
2.3	Check Valve, 65 mm Ø, swing type, cast iron, flanged flanged ends, Class 150	Supply, Install and Test		sets	2	(P _____ ) P _____	
2.4	Globe Valve, 25mm Ø, cast bronze, flanged or screwed ends, OSY or rising stem, Class 150	Supply, Install and Test		sets	3	(P _____ ) P _____	
2.5	Simplex strainer, 65mm Ø, basket type, cast iron body, stainless steel element with magnet, flanged ends, 40 mesh minimum	Supply, Install and Test		sets	2	(P _____ ) P _____	
2.6	Flowmeter, 10 m <sup>3</sup> /hr rated flow, aluminum body, flanged ends, with LCD display, internal battery to last at least 5 years, ±0.5% accuracy, 0.02% repeatability, 150 lb, monitors accumulated total flow, resettable total flow and instantaneous flow, equipped with pulse generator or 4-20mA current output	Supply, Install and Test		set	1	(P _____ ) P _____	
2.7	Pressure gauge, 100 mm Ø dial gauge, buordon tube type, with dampener and isolation valve	Supply, Install and Test		sets	2	(P _____ ) P _____	
2.8	Spare parts for fuel oil transfer pump for one (1) year operation per Manufacturer's recommendation and as specified in the technical specifications to include the following: a) One (1) set of bearings for pump and motor b) One (1) set of bushings, wearing rings, packing and gaskets for the pump	Supply and Delivery		lot	1	(P _____ ) P _____	

Name of Firm  
NATIONAL POWER CORPORATION

Name and Signature of Authorized Representative

Designation



SECTION VII - BILL OF QUANTITIES

LuzP20Z1179Se

**BILL OF QUANTITIES**

**1 X 60 KL FUEL OIL STORAGE TANK FOR JOMALIG DPP**

Item No.	Description of Work or Materials	Work to be Done	Ref. Clause	Unit	Estimated Quantity	Unit Price in Pesos (Words and Figures)	Total Amount
<b>MW-3.0 FUEL &amp; WASTE OIL TRANSFER PIPING SYSTEM</b>							
			<b>MW-4.0 &amp; Drawings</b>				
3.1	Fuel transfer pipe, 80mm Ø, ASTM A 53 Gr. B, seamless, schedule 40 and its associated fittings, pipe supports, gaskets, supports, flanges, bolts and other accessories	Supply, Excavate, Install, Test, & Backfill		lm	6	(P _____ ) P _____	
3.2	Fuel transfer pipe, 65mm Ø, ASTM A 53 Gr. B, seamless, schedule 40 and its associated fittings, pipe supports, gaskets, supports, flanges, bolts and other accessories	Supply, Excavate, Install, Test, & Backfill		lm	120	(P _____ ) P _____	
3.3	Fuel transfer pipe, 25mm Ø, ASTM A 53 Gr. B, seamless, schedule 40 and its associated fittings, pipe supports, gaskets, supports, flanges, bolts and other accessories	Supply, Install and Test		lm	12	(P _____ ) P _____	
3.4	Waste Oil Pipe, 160mm O.D. (150mm DN), unplasticized PVC, Sch 80 or class 150, conforming to ASTM D-1784, and its associated fittings, pipe supports and other accessories as described in the technical specifications or drawings.	Supply, Install and Test		lm	6	(P _____ ) P _____	
<b>4.0 FIRE EXTINGUISHERS</b>			<b>MW-6.0</b>				
4.1	Portable Fire Extinguisher, clean agent, (HCFC or Halotron I Type), 7.1 kg. (15.5 lbs), wall-hung type with bracket and accessories and UL/FM approved	Supply, Install Test		set	1	(P _____ ) P _____	
4.2	Wheeled Type Fire Extinguisher (Foam-AFFF) complete with self-contained cylinder mounted on frame with handle, floorstand and steel or rubberized wheels, 125 liters (33 gallons) capacity, associated valves, dial gauge indicator, nitrogen expellant tank for unit pressurization, 15 m long discharge hose of appropriate size fitted with couplings and foam nozzle assembly	Supply, Install Test		set	1	(P _____ ) P _____	

Name of Firm

Name and Signature of Authorized Representative

Designation



SECTION VII - BILL OF QUANTITIES

LuzP20Z1179Sa

**BILL OF QUANTITIES**

**1 X 60 KL FUEL OIL STORAGE TANK FOR JOMALIG DPP**

Item No.	Description of Work or Materials	Work to be Done	Ref. Clause	Unit	Estimated Quantity	Unit Price in Pesos (Words and Figures)	Total Amount
5.0	<b>MISCELLANEOUS</b>						
5.1	Tagging or Labaels for Equipment, Valve, Piping, Instruments and its fixing accessories as described in the bid documents	Supply, Install Test	GW-5.0	lot	1	_____ (P _____) P _____	
5.2	Painting for Fuel Oil Piping & Equipment, its associated valves, fittings, supports and other accessories including touch-up for	Supply, Install Test	GW-10.0	lot	1	_____ (P _____) P _____	
<b>TOTAL MECHANICAL WORKS</b>						_____ (P _____) P _____	

\_\_\_\_\_  
Name of Firm

\_\_\_\_\_  
Name and Signature of Authorized Representative

\_\_\_\_\_  
Designation

NATIONAL POWER CORPORATION



**SECTION VII - BILL OF QUANTITIES  
1 X 60 KL FOST FOR JOMALIG DPP  
ELECTRICAL WORKS**

Item No.	Description of Work or Materials	Work to be Done	Ref.	Unit	Total Quantity	Unit Price in Pesos (Words and Figures)	Total Amount
<b>1.0</b>	<b>PUMP MOTOR CONTROL, PROTECTION AND MONITORING PANEL</b>						
a.	Local Control and Protection Panel including NEMA-1 Class Combination Motor Starter with 100AF/70AT MCCB, 1-Phase, Indicating Lights, etc. (to be installed in the Pump House)	Furnish, Install and Test	EW-TS & BD	set	1	_____ P _____ (P _____)	_____
b.	Remote Control Panel including Start/Stop Button, Indicating Lights, Instrumentation Cables, etc. (to be installed in the Engine Area)	Furnish, Install and Test	EW-TS & BD	set	1	_____ P _____ (P _____)	_____
c.	Monitoring Panel including Indicating Lights, Instrumentation Cables, etc. (to be installed in the Control Room)	Furnish, Install and Test	EW-TS & BD	set	1	_____ P _____ (P _____)	_____
<b>2.0</b>	<b>LIGHTING FIXTURES</b>						
a.	Fixture Type A (Portable Emergency Light, 2x2 W LED with built-in battery and battery charger)	Furnish, Install and Test	EW-TS & BD	set(s)	1	_____ P _____ (P _____)	_____

\_\_\_\_\_  
Name of Firm

\_\_\_\_\_  
Name and Signature of Authorized Representative

\_\_\_\_\_  
Designation



SECTION VII - BILL OF QUANTITIES

LuzP2021179Se

**SECTION VII - BILL OF QUANTITIES  
1 X 60 KL FOST FOR JOMALIG DPP  
ELECTRICAL WORKS**

Item No.	Description of Work or Materials	Work to be Done	Ref.	Unit	Total Quantity	Unit Price in Pesos (Words and Figures)	Total Amount
	b. Fixture Type B (1x9 W Compact LED Lighting Fixture)	Furnish, Install and Test	EW-TS & BD	set(s)	1	(P _____)	P _____
<b>3.0</b>	<b>OUTLETS AND SWITCHES INCLUDING PLATE COVER, FLUSH-MOUNTED, GROUNDING TYPE</b>						
	a. Convenience Outlet Duplex, with cover 16A, 230V, 1-phase	Furnish, Install and Test	EW-TS & BD	set(s)	1	(P _____)	P _____
	b. Outlet for Emergency Lighting Fixture Single Receptacle 16A, 230V, 1-phase	Furnish, Install and Test	EW-TS & BD	set(s)	1	(P _____)	P _____
	c. Single Pole Wall Switch, 10A, 230V	Furnish, Install and Test	EW-TS & BD	set(s)	1	(P _____)	P _____
	d. 50AF/15AT, 2-Pole, MCB, Enclosed Circuit Breaker (NEMA 1 Enclosure)	Furnish, Install and Test	EW-TS & BD	set(s)	1	(P _____)	P _____
<b>4.0</b>	<b>BUS CONDUCTOR AND INSULATED COPPER CONDUCTORS INCLUDING TERMINAL LUGS, CABLE TIES, IDENTIFICATION TAGS, ETC.</b>						
	a. 8.0 mm <sup>2</sup> , 600 V, Heat Resistant Thermoplastic, (THHN/THWN-2), Copper Conductor	Furnish, Lay and Test	EW-TS & BD	li.m	95	(P _____)	P _____
	a. 5.5 mm <sup>2</sup> , 600 V, Heat Resistant Thermoplastic, (THHN/THWN-2), Copper Conductor	Furnish, Lay and Test	EW-TS & BD	li.m	45	(P _____)	P _____

\_\_\_\_\_  
Name of Firm

\_\_\_\_\_  
Name and Signature of Authorized Representative

\_\_\_\_\_  
Designation



SECTION VII - BILL OF QUANTITIES

**SECTION VII - BILL OF QUANTITIES  
1 X 60 KL FOST FOR JOMALIG DPP  
ELECTRICAL WORKS**

Item No.	Description of Work or Materials	Work to be Done	Ref.	Unit	Total Quantity	Unit Price in Pesos (Words and Figures)	Total Amount
b.	3.5 mm <sup>2</sup> , 600 V, Heat Resistant Thermoplastic, (THHN/THWN-2), Copper Conductor	Furnish, Lay and Test	EW-TS & BD	li.m	20	_____ P _____ (P _____)	_____ P
<b>5.0</b>	<b>EMBEDDED AND/OR NON-EMBEDDED CONDUITS INCLUDING BOXES, LOCKNUTS, ELBOWS, BOLTS AND OTHER FITTINGS</b>						
a.	25 mmØ uPVC	Furnish and Install	EW-TS & BD	li.m	45	_____ P _____ (P _____)	_____ P
b.	20 mmØ uPVC	Furnish and Install	EW-TS & BD	li.m	10	_____ P _____ (P _____)	_____ P
c.	Boxes, Locknuts, Elbows and Other Fittings	Furnish and Install	EW-TS & BD	lot	1	_____ P _____ (P _____)	_____ P
<b>TOTAL ELECTRICAL WORKS</b>						_____ P _____ (P _____)	_____ P

\_\_\_\_\_  
Name of Firm

\_\_\_\_\_  
Name and Signature of Authorized Representative

\_\_\_\_\_  
Designation



## SECTION VIII

# BIDDING FORMS

## SECTION VIII – BIDDING FORMS

### TABLE OF CONTENTS

NPCSF-INFR-01	- Checklist of Technical and Financial Envelope Requirements for Bidders
NPCSF-INFR-02	- List of all Ongoing Government & Private Construction Contracts Including Contracts Awarded but not yet Started
NPCSF-INFR-03	- Statement of the bidder's Single Largest Completed Contract (SLCC) similar to the contract to be bid
NPCSF-INFR-04	- Computation of Net Financial Contracting Capacity (NFCC)
NPCSF-INFR-05	- Joint Venture Agreement
NPCSF-INFR-06a	- Form of Bid Security : Bank Guarantee
NPCSF-INFR-06b	- Form of Bid Security : Surety Bond
NPCSF-INFR-06c	- Bid Securing Declaration Form
NPCSF-INFR-07	- Omnibus Sworn Statement (Revised)
NPCSF-INFR-08	- Contractor's Organizational Chart for the Project
NPCSF-INFR-09	- List of Key Personnel Proposed to be Assigned to the Project
NPCSF-INFR-10a	- Key Personnel's Certificate of Employment (Professional Personnel)
NPCSF-INFR-10b	- Key Personnel's Certificate of Employment (Construction Safety and Health Officer)
NPCSF-INFR-11	- Key Personnel's Bio-Data
NPCSF-INFR-12	- List of Equipment, Owned or Leased and/or under Purchase Agreement, Pledged to the Proposed Project
NPCSF-INFR-13	- Bid Letter
NPCSF-INFR-14	- Detailed Cost Estimate Form
NPCSF-INFR-15	- Summary Sheets of Materials Prices, Labor Rates and Equipment Rental Rates

Standard Form No: NPCSF-INFR-01

**Checklist of Technical & Financial Envelope Requirements for Bidders**

**A. THE 1<sup>ST</sup> ENVELOPE (TECHNICAL COMPONENT) SHALL CONTAIN THE FOLLOWING:**

**1. ELIGIBILITY DOCUMENTS**

**a. (CLASS A)**

➤ Any of the following:

- PhilGEPS Certificate of Registration and Membership under Platinum Category in accordance with Section 8.5.2 of the IRR;

**OR:**

- The following updated and valid Class "A" eligibility documents enumerated under "Annex A" of the Platinum Membership:

- Registration Certificate from the Securities and Exchange Commission (SEC) for corporations, Department of Trade and Industry (DTI) for sole proprietorship, or Cooperative Development Authority (CDA) for cooperatives;
- Mayor's/Business permit issued by the city or municipality where the principal place of business of the prospective bidder is located, or the equivalent document for Exclusive Economic Zones or Areas.

In cases of recently expired Mayor's/Business permits, it shall be accepted together with the official receipt as proof that the bidder has applied for renewal within the period prescribed by the concerned local government unit, provided that the renewed permit shall be submitted as a post qualification requirement in accordance with Section 34.2 of the Revised IRR of RA 9184.

- The prospective bidder's audited financial statements, showing, among others, the prospective bidder's total and current assets and liabilities, stamped "received" by the BIR or its duly accredited and authorized institutions, for the preceding calendar year which should not be earlier than two (2) years from the date of bid submission.
- Tax clearance per Executive Order 398, Series of 2005, as finally reviewed and approved by the BIR;
- Valid Philippine Contractors Accreditation Board (PCAB) license and registration for the type and cost of the contract for this Project or Special PCAB License in case of Joint Ventures.

**OR:**

- A combination thereof.

➤ Statement of all its ongoing government and private contracts if any, whether similar or not similar in nature and complexity to the contract to be bid (NPCSF-INFR-02)

➤ The Statement of the bidder's Single Largest Completed Contract (SLCC) similar to the contract to be bid, and whose value, adjusted to current prices using the Philippine Statistics Authority (PSA) consumer price index, must be at least 50% of the ABC (NPCSF-INFR-03) complete with the following supporting documents:

- Contract
- Owner's Certificate of Final Acceptance issued by the project owner other than the contractor or a final rating of at least Satisfactory in the Constructors Performance Evaluation System (CPES). In case of contracts with the private sector, an equivalent document (Ex. Official Receipt or Sales Invoice) shall be submitted

*This Checklist of Requirements shall be provided to prospective suppliers/contractors including all forms. Suppliers/contractors are encouraged to consult this checklist before submitting their proposals on the deadline for the submission and receipt of offers.*



Standard Form No: NPCSF-INFR-01  
Page 2 of 3

*(The Single Largest Completed Contract (SLCC) as declared by the bidder shall be verified and validated to ascertain such completed contract. Hence, bidders must ensure access to sites of such projects/equipment to NPC representatives for verification and validation purposes during post-qualification process.*

*It shall be a ground for disqualification, if verification and validation cannot be conducted due to inaccessibility of the site for whatever reason or fault of the bidder.)*

- Special PCAB License in case of Joint Ventures
- Duly signed computation of its Net Financial Contracting Capacity (NFCC) at least equal to the ABC (NPCSF-INFR-04);
- b. (CLASS B)**
- Valid Joint Venture Agreement, if applicable (NPCSF-INFR-05)

## 2. Technical Documents

- Bid Security, any one of the following:
  - Bid Securing Declaration (NPCSF-INFR-06c)  
OR
  - Cash or Cashier's/Manager's check issued by a Universal or Commercial Bank – 2% of ABC;  
OR
  - Bank draft/guarantee or irrevocable letter of credit issued by a Universal or Commercial Bank: (NPCSF-INFR-06a) - 2% of ABC;  
OR
  - Surety Bond callable upon demand issued by a reputable surety or insurance company (NPCSF-INFR-06b) - 5% of ABC, with
    - Certification from the Insurance Commission as authorized company to issue surety
- Duly signed, completely filled-out and notarized Omnibus Sworn statement (Revised) (NPCSF-INFR-07), complete with the following attachments:
  - For Sole Proprietorship:
    - Special Power of Attorney
  - For Partnership/Corporation/Cooperative/Joint Venture:
    - Document showing proof of authorization (e.g., duly notarized Secretary's Certificate, Board/Partnership Resolution, or Special Power of Attorney, whichever is applicable)
- Organization Chart for the project (NPCSF-INFR-08)
- Duly Signed List of Contractor's Key Personnel (based on the minimum key personnel) with complete supporting documents (NPCSF-INFR-09, 10a, 10b & 11)
- Duly Signed List of Contractor's Equipment (owned, leased or under purchase agreement (NPCSF-INFR-12), with
  - Proof of ownership and/or certificate of availability issued by Equipment Lessors

*This Checklist of Requirements shall be provided to prospective suppliers/contractors including all forms. Suppliers/contractors are encouraged to consult this checklist before submitting their proposals on the deadline for the submission and receipt of offers.*

Standard Form No: NPCSF-INFR-01

Page 3 of 3

- Duly signed and completely filled-out Technical Data Sheets (Mechanical Works), Section VI – Part II (MW)
- Complete eligibility documents of proposed sub-contractor, if applicable

**B. THE 2<sup>ND</sup> ENVELOPE (FINANCIAL COMPONENT) SHALL CONTAIN THE FOLLOWING:**

- Duly signed Bid Letter indicating the total bid amount in accordance with the prescribed form (NPCSF-INFR-13)
- Duly signed and completely filled-out Bill of Quantities (Section VII) indicating the unit and total prices per item and the total amount in the prescribed Bill of Quantities form.
- Duly Signed Detailed Estimates for each items of work showing the computations in arriving at each item's unit prices used in coming up with the bid (NPCSF-INFR-14)
- Summary sheets indicating the direct unit prices of construction materials, labor rates and equipment rental rates used in coming up with the bid (NPCSF-INFR-15)

**CONDITIONS:**

1. *Each Bidder shall submit one copy of the first and second components of its Bid. NPC may request additional hard copies and/or electronic copies of the Bid. However, failure of the Bidders to comply with the said request shall not be a ground for disqualification.*
2. *A Bidder not submitting bid for reason that his cost estimate is higher than the ABC, is required to submit his letter of non-participation/regret supported by corresponding detailed estimates. Failure to submit the two (2) documents shall be understood as acts that tend to defeat the purpose of public bidding without valid reason as stated under Section 69.1.(i) of the revised IRR of R.A. 9184.*

SECTION VIII – BIDDING FORMS

Standard Form Number: NPCSF-INFR-02

**List of All Ongoing Government and Private Contracts Including Contract Awarded But Not Yet Started**

Business Name : \_\_\_\_\_  
 Business Address : \_\_\_\_\_

Name of Contract/Location/ Project Cost	a. Owner's Name b. Address c. Telephone Nos.	Nature of Work	Contractor's Role		a. Date Awarded b. Date Started c. Date of Completion or Estimated Completion Time	Value of Outstanding Works
			Description	%		
<b>Government</b>						
<b>Private</b>						
					<b>Total Cost</b>	

The bidder shall declare in this form all his on-going government and private contracts including contracts where the bidder (either as individual or as a Joint Venture) is a partner in a Joint Venture agreement other than his current joint venture where he is a partner. Non declaration will be a ground for disqualification of bid.

Note : This statement shall be supported with the following documents for all the contract(s) stated above which shall be submitted during Post-qualification:

1. Contract/Purchase Order and/or Notice of Award
2. Certification coming from the project owner/client that the performance is satisfactory as of the bidding date.

Submitted by : \_\_\_\_\_  
 (Printed Name & Signature)  
 Designation : \_\_\_\_\_  
 Date : \_\_\_\_\_

SECTION VIII – BIDDING FORMS

Standard Form Number: NPCSF-INFR-03

**The Statement of the bidder's Single Largest Completed Contract (SLCC) similar to the contract to be bid**

Business Name : \_\_\_\_\_  
 Business Address : \_\_\_\_\_

Name of Contract	a. Owner's Name b. Address c. Telephone Nos.	Nature of Work	Contractor's Role		a. Amount at Award b. Amount at Completion c. Duration	a. Date Awarded b. Contract Effectivity c. Date Completed
			Description	%		

- Notes:
1. The bidder must state only one (1) Single Largest Completed Contract (SLCC) similar to the contract to be bid.
  2. Supporting documents such as Contract/Purchase Order and any of the following: Owner's Certificate of Final Acceptance issued by the project owner other than the contractor; or A final rating of at least Satisfactory in the Constructors Performance Evaluation System (CPES); or Official Receipt (O.R); or Sales Invoice for the contract stated above shall be submitted during Bid Opening.

Submitted by \_\_\_\_\_  
 (Printed Name & Signature)  
 Designation : \_\_\_\_\_  
 Date : \_\_\_\_\_

Standard Form Number: NPCSF-INFR-04

**NET FINANCIAL CONTRACTING CAPACITY (NFCC)**

A. Summary of the Bidder's/Contractor's assets and liabilities on the basis of the income tax return and audited financial statement for the immediately preceding calendar year are:

		Year 20__
1.	Total Assets	
2.	Current Assets	
3.	Total Liabilities	
4.	Current Liabilities	
5.	Net Worth (1-3)	
6.	Net Working Capital (2-4)	

B. The Net Financial Contracting Capacity (NFCC) based on the above data is computed as follows:

NFCC = [(Current assets minus current liabilities) x 15] minus the value of all outstanding or uncompleted portions of the projects under ongoing contracts, including awarded contracts yet to be started coinciding with the contract for this Project.

NFCC = P \_\_\_\_\_

Herewith attached is certified true copy of the audited financial statement, stamped "RECEIVED" by the BIR or BIR authorized collecting agent for the immediately preceding calendar year.

Submitted by:

\_\_\_\_\_  
 Name of Bidder/Contractor

\_\_\_\_\_  
 Signature of Authorized Representative

Date : \_\_\_\_\_

Standard Form Number: NPCSF-INFR-05

**JOINT VENTURE AGREEMENT**

**KNOW ALL MEN BY THESE PRESENTS:**

That this JOINT VENTURE AGREEMENT is entered into by and between:  
\_\_\_\_\_, of legal age, *(civil status)* \_\_\_\_\_, authorized representative of  
\_\_\_\_\_ and a resident of \_\_\_\_\_.

- and -

\_\_\_\_\_, of legal age, *(civil status)* \_\_\_\_\_, authorized representative of  
\_\_\_\_\_ a resident of \_\_\_\_\_.

That both parties agree to join together their capital, manpower, equipment, and other resources and efforts to enable the Joint Venture to participate in the Bidding and Undertaking of the hereunder stated Contract of the National Power Corporation.

**NAME OF PROJECT**

**CONTRACT AMOUNT**

\_\_\_\_\_

That the capital contribution of each member firm:

NAME OF FIRM	CAPITAL CONTRIBUTION
1.	P
2.	P

That both parties agree to be jointly and severally liable for their participation in the Bidding and Undertaking of the said contract.

That both parties agree that \_\_\_\_\_ and/or \_\_\_\_\_ shall be the Official Representative/s of the Joint Venture, and are granted full power and authority to do, execute and perform any and all acts necessary and/or to represent the Joint Venture in the Bidding and Undertaking of the said contract, as fully and effectively and the Joint Venture may do and if personally present with full power of substitution and revocation.

That this Joint Venture Agreement shall remain in effect only for the above stated Contract until terminated by both parties.

\_\_\_\_\_  
*Name & Signature of Authorized Representative*

\_\_\_\_\_  
*Official Designation*

\_\_\_\_\_  
*Name of Firm*

\_\_\_\_\_  
*Name & Signature of Authorized Representative*

\_\_\_\_\_  
*Official Designation*

\_\_\_\_\_  
*Name of Firm*

*Witnesses*

1. \_\_\_\_\_

2. \_\_\_\_\_

**[Jurat]**

*[Format shall be based on the latest Rules on Notarial Practice]*

Standard Form Number: NPCSF-INFR-06a

**FORM OF BID SECURITY (BANK GUARANTEE)**

WHEREAS, (Name of Bidder) (hereinafter called "the Bidder") has submitted his bid dated (Date) for the [name of project] (hereinafter called "the Bid").

KNOW ALL MEN by these presents that We (Name of Bank) of (Name of Country) having our registered office at \_\_\_\_\_ (hereinafter called "the Bank" are bound unto National Power Corporation (hereinafter called "the Entity") in the sum of [amount in words & figures as prescribed in the bidding documents] for which payment well and truly to be made to the said Entity the Bank binds himself, his successors and assigns by these presents.

SEALED with the Common Seal of the said Bank this \_\_\_\_\_ day of \_\_\_\_\_ 20\_\_\_\_.

THE CONDITIONS of this obligation are that:

- 1) if the Bidder withdraws his Bid during the period of bid validity specified in the Bidding Documents; or
- 2) if the Bidder does not accept the correction of arithmetical errors of his bid price in accordance with the Instructions to Bidder; or
- 3) if the Bidder, having determined as the LCB, fails or refuses to submit the required tax clearance, latest income and business tax returns and PhilGEPs registration certificate within the prescribed period; or
- 4) if the Bidder having been notified of the acceptance of his bid and award of contract to him by the Entity during the period of bid validity:
  - a) fails or refuses to execute the Contract; or
  - b) fails or refuses to submit the required valid JVA, if applicable; or
  - c) fails or refuses to furnish the Performance Security in accordance with the Instructions to Bidders;

we undertake to pay to the Entity up to the above amount upon receipt of his first written demand, without the Entity having to substantiate its demand, provided that in his demand the Entity will note that the amount claimed by it is due to the occurrence of any one or combination of the four (4) conditions stated above.

The Guarantee will remain in force up to 120 days after the opening of bids or as it may be extended by the Entity, notice of which extension(s) to the Bank is hereby waived. Any demand in respect of this Guarantee should reach the Bank not later than the above date.

DATE \_\_\_\_\_ SIGNATURE OF THE BANK \_\_\_\_\_

WITNESS \_\_\_\_\_ SEAL \_\_\_\_\_

\_\_\_\_\_  
 (Signature, Name and Address)

Standard Form Number: NPCSF-INFR-06b

**FORM OF BID SECURITY (SURETY BOND)**

BOND NO.: \_\_\_\_\_ DATE BOND EXECUTED: \_\_\_\_\_

By this bond, We (Name of Bidder) \_\_\_\_\_ (hereinafter called "the Principal") and (Name of Surety) \_\_\_\_\_ of (Name of Country of Surety) \_\_\_\_\_, authorized to transact business in the Philippines (hereinafter called "the Surety") are held and firmly bound unto National Power Corporation (hereinafter called "the Employer") as Obligee, in the sum of (amount in words & figures as prescribed in the bidding documents), callable on demand, for the payment of which sum, well and truly to be made, we, the said Principal and Surety bind ourselves, our successors and assigns, jointly and severally, firmly by these presents.

SEALÉD with our seals and dated this \_\_\_\_\_ day of \_\_\_\_\_ 20 \_\_\_\_\_

WHEREAS, the Principal has submitted a written Bid to the Employer dated the \_\_\_\_\_ day of \_\_\_\_\_ 20 \_\_\_\_\_, for the \_\_\_\_\_ (hereinafter called "the Bid").

NOW, THEREFORE, the conditions of this obligation are:

- 1) if the Bidder withdraws his Bid during the period of bid validity specified in the Bidding Documents; or
- 2) if the Bidder does not accept the correction of arithmetical errors of his bid price in accordance with the Instructions to Bidder; or
- 3) if the Bidder, having determined as the LCB, fails or refuses to submit the required tax clearance, latest income and business tax returns and PhilGEPs registration certificate within the prescribed period; or
- 4) if the Bidder having been notified of the acceptance of his bid and award of contract to him by the Entity during the period of bid validity:
  - d) fails or refuses to execute the Contract; or
  - e) fails or refuses to submit the required valid JVA, if applicable; or
  - f) fails or refuses to furnish the Performance Security in accordance with the Instructions to Bidders;

then this obligation shall remain in full force and effect, otherwise it shall be null and void.

PROVIDED HOWEVER, that the Surety shall not be:

- a) liable for a greater sum than the specified penalty of this bond, nor
- b) liable for a greater sum than the difference between the amount of the said Principal's Bid and the amount of the Bid that is accepted by the Employer.



Standard Form Number: NPCSF-INFR-06b  
Page 2 of 2

This Surety executing this instrument hereby agrees that its obligation shall be valid for 120 calendar days after the deadline for submission of Bids as such deadline is stated in the Instructions to Bidders or as it may be extended by the Employer, notice of which extension(s) to the Surety is hereby waived.

PRINCIPAL \_\_\_\_\_ SURETY \_\_\_\_\_

SIGNATURE(S) \_\_\_\_\_ SIGNATURES(S) \_\_\_\_\_

NAME(S) AND TITLE(S) \_\_\_\_\_ NAME(S) \_\_\_\_\_

SEAL \_\_\_\_\_ SEAL \_\_\_\_\_

Standard Form No: NPCSF-INFR-06c

REPUBLIC OF THE PHILIPPINES )  
CITY OF \_\_\_\_\_ ) S.S.

**BID-SECURING DECLARATION**

**SUPPLY, DELIVERY, INSTALLATION AND TEST OF 1 X 35 KL AND 2 X 60 KL  
FOST FOR PATNANUNGAN DPP, PALANAN DPP AND JOMALIG DPP INCLUDING  
CONSTRUCTION OF ASSOCIATED FACILITIES UNDER PACKAGE 1 (LuzP20Z1179Se)**

To: **National Power Corporation**  
BIR Road cor. Quezon Ave.  
Diliman, Quezon City

I/We<sup>1</sup>, the undersigned, declare that:

1. I/We understand that, according to your conditions, bids must be supported by a Bid Security, which may be in the form of a Bid-Securing Declaration.
2. I/We accept that: (a) I/we will be automatically disqualified from bidding for any contract with any procuring entity for a period of two (2) years upon receipt of your Blacklisting Order; and, (b) I/we will pay the applicable fine provided under Section 6 of the Guidelines on the Use of Bid Securing Declaration, within fifteen (15) days from receipt of the written demand by the Procuring Entity for the commission of acts resulting to the enforcement of the Bid Securing Declaration under Sections 23.1 (b), 34.2, 40.1 and 69.1, except 69.1 (f) of the IRR of R.A. 9184; without prejudice to other legal action the government may undertake.
3. I/We understand that this Bid-Securing Declaration shall cease to be valid on the following circumstances:
  - (a) Upon expiration of the bid validity period, or any extension thereof pursuant to your request;
  - (b) I am/we are declared ineligible or post-disqualified upon receipt of your notice to such effect, and (i) I/we failed to timely file a request for reconsideration or (ii) I/we filed a waiver to avail of said right;
  - (c) I am/we are declared as the bidder with the Lowest Calculated and Responsive Bid, and I/we have furnished the performance security and signed the Contract.

IN WITNESS WHEREOF, I/we have hereunto set my hand this \_\_\_\_ day of \_\_\_\_  
20\_\_\_\_ at \_\_\_\_\_, Philippines.

\_\_\_\_\_  
[Name and Signature of Bidder's Representative/  
Authorized Signatory] [Signatory's legal capacity]  
Affiant

**[Jurat]**

[Format shall be based on the latest Rules on Notarial Practice]

<sup>1</sup> Select one and delete the other. Adopt same instruction for similar terms throughout the document.

Standard Form No: NPCSF-INFR-07b

**Omnibus Sworn Statement (Revised)**

REPUBLIC OF THE PHILIPPINES )  
 CITY/MUNICIPALITY OF \_\_\_\_\_ ) S.S.

**AFFIDAVIT**

I, [Name of Affiant], of legal age, [Civil Status], [Nationality], and residing at [Address of Affiant], after having been duly sworn in accordance with law, do hereby depose and state that:

1. *[Select one, delete the other:]*

*[If a sole proprietorship:]* I am the sole proprietor or authorized representative of [Name of Bidder] with office address at [address of Bidder];

*[If a partnership, corporation, cooperative, or joint venture:]* I am the duly authorized and designated representative of [Name of Bidder] with office address at [address of Bidder];

2. *[Select one, delete the other:]*

*[If a sole proprietorship:]* As the owner and sole proprietor, or authorized representative of [Name of Bidder], I have full power and authority to do, execute and perform any and all acts necessary to participate, submit the bid, and to sign and execute the ensuing contract for [Name of the Project] of the [Name of the Procuring Entity], as shown in the attached duly notarized Special Power of Attorney;

*[If a partnership, corporation, cooperative, or joint venture:]* I am granted full power and authority to do, execute and perform any and all acts necessary to participate, submit the bid, and to sign and execute the ensuing contract for [Name of the Project] of the [Name of the Procuring Entity], as shown in the attached [state title of attached document showing proof of authorization (e.g., duly notarized Secretary's Certificate, Board/Partnership Resolution, or Special Power of Attorney, whichever is applicable)];

3. [Name of Bidder] is not "blacklisted" or barred from bidding by the Government of the Philippines or any of its agencies, offices, corporations, or Local Government Units, foreign government/foreign or international financing institution whose blacklisting rules have been recognized by the Government Procurement Policy Board, by itself or by relation, membership, association, affiliation, or controlling interest with another blacklisted person or entity as defined and provided for in the Uniform Guidelines on Blacklisting;

4. Each of the documents submitted in satisfaction of the bidding requirements is an authentic copy of the original, complete, and all statements and information provided therein are true and correct;

5. [Name of Bidder] is authorizing the Head of the Procuring Entity or its duly authorized representative(s) to verify all the documents submitted;

6. *[Select one, delete the rest:]*

*[If a sole proprietorship:]* The owner or sole proprietor is not related to the Head of the Procuring Entity, members of the Bids and Awards Committee (BAC), the Technical Working Group, and the BAC Secretariat, the head of the Project Management Office or the end-user unit, and the project consultants by consanguinity or affinity up to the third civil degree;

*[If a partnership or cooperative:]* None of the officers and members of *[Name of Bidder]* is related to the Head of the Procuring Entity, members of the Bids and Awards Committee (BAC), the Technical Working Group, and the BAC Secretariat, the head of the Project Management Office or the end-user unit, and the project consultants by consanguinity or affinity up to the third civil degree;

*[If a corporation or joint venture:]* None of the officers, directors, and controlling stockholders of *[Name of Bidder]* is related to the Head of the Procuring Entity, members of the Bids and Awards Committee (BAC), the Technical Working Group, and the BAC Secretariat, the head of the Project Management Office or the end-user unit, and the project consultants by consanguinity or affinity up to the third civil degree;

7. *[Name of Bidder]* complies with existing labor laws and standards; and
8. *[Name of Bidder]* is aware of and has undertaken the responsibilities as a Bidder in compliance with the Philippine Bidding Documents, which includes:
  - a. Carefully examining all of the Bidding Documents;
  - b. Acknowledging all conditions, local or otherwise, affecting the implementation of the Contract;
  - c. Making an estimate of the facilities available and needed for the contract to be bid, if any; and
  - d. Inquiring or securing Supplemental/Bid Bulletin(s) issued for the *[Name of the Project]*.
9. *[Name of Bidder]* did not give or pay directly or indirectly, any commission, amount, fee, or any form of consideration, pecuniary or otherwise, to any person or official, personnel or representative of the government in relation to any procurement project or activity.
10. In case advance payment was made or given, failure to perform or deliver any of the obligations and undertakings in the contract shall be sufficient grounds to constitute criminal liability for Swindling (Estafa) or the commission of fraud with unfaithfulness or abuse of confidence through misappropriating or converting any payment received by a person or entity under an obligation involving the duty to deliver certain goods or services, to the prejudice of the public and the government of the Philippines pursuant to Article 315 of Act No. 3815 s. 1930, as amended, or the Revised Penal Code.

IN WITNESS WHEREOF, I have hereunto set my hand this \_\_\_ day of \_\_\_, 20\_\_ at \_\_\_\_\_, Philippines.

*[Insert NAME OF BIDDER OR ITS AUTHORIZED REPRESENTATIVE]*

*[Insert signatory's legal capacity]*

Affiant

**[Jurat]**

*[Format shall be based on the latest Rules on Notarial Practice]*

Standard Form Number: NPCSF-INFR-08

## CONTRACTOR'S ORGANIZATIONAL CHART FOR THE CONTRACT

Submit Copy of the Organizational Chart that the Contractor intends to use to execute the Contract if awarded to him. Indicate in the chart the names of the Project Manager, Project Engineer, Foreman and other Key Engineering Personnel.

Attach the required Proposed Organizational Chart for the Contract as stated above

### NOTES:

1. *This organization chart should represent the "Contractor's Organization" required for the Project, and not the organizational chart of the entire firm.*
2. *Each such nominated engineer/key personnel shall comply with and submit duly accomplished forms NPCSF-INFR-10a, NPCSF-INFR-10b and NPCSF-INFR-11.*
3. *All these are required to be in the Technical Envelope of the Bidder.*

Standard Form Number: NPCSF-INFR-09

**LIST OF KEY PERSONNEL PROPOSED TO BE ASSIGNED TO THE CONTRACT**  
*(Based on the Minimum Key Personnel Required in the Bidding Documents)*

Business Name: \_\_\_\_\_  
 Business: \_\_\_\_\_

	DESIGNATION			
1 Name				
2 Address				
3 Date of Birth				
4 Employed Since				
5 Experience				
6 Previous Employment				
7 Education				
8 PRC License				

**Required Attachments:**

1. Certificate of Employment, Bio Data and Construction Safety and Health Training Certificate of the Safety Officer
2. Certificate of Employment, Bio Data and valid PRC License of the (professional) personnel

Submitted by: \_\_\_\_\_  
 (Printed Name & Signature)

Designation: \_\_\_\_\_

Date: \_\_\_\_\_

*One of the requirements from the bidder to be included in its Technical Envelope is a list of contractor's key personnel (based on the minimum key personnel required in the bidding documents) to be assigned to the contract to be bid, with their complete qualification and experience data (including the key personnel's signed written commitment to work for the project once awarded the contract).*

Standard Form Number: NPCSF-INFR-10a

**KEY PERSONNEL'S CERTIFICATE OF EMPLOYMENT  
(PROFESSIONAL PERSONNEL)**

\_\_\_\_\_  
Issuance Date

**THE PRESIDENT**  
National Power Corporation  
BIR Road cor. Quezon Ave.  
Diliman, Quezon City

Dear Sir:

I am (Name of Nominee) a Licensed \_\_\_\_\_ Engineer with  
Professional License No. \_\_\_\_\_ issued on (date of issuance) at (place of  
(issuance)

I hereby certify that (Name of Bidder) has engaged my services as  
(Designation) for the (Name of Project), if awarded to it.

As (Designation), I supervised the following completed projects similar to  
the contract under bidding:

NAME OF PROJECT	OWNER	COST	DATE COMPLETED
_____	_____	_____	_____

At present, I am supervising the following projects:

NAME OF PROJECT	OWNER	COST	DATE COMPLETED
_____	_____	_____	_____

In case of my separation for any reason whatsoever from the above-mentioned  
Contractor, I shall notify the National Power Corporation at least twenty one (21) days before the  
effective date of my separation.

As (Designation), I know I will have to stay in the job site all the  
time to supervise and manage the Contract works to the best of my ability, and aware that I am  
authorized to handle only one (1) contract at a time.

I do not allow the use of my name for the purpose of enabling the above-mentioned  
Contractor to qualify for the Contract without any firm commitment on my part to assume the post  
of (Designation) therefor, if the contract is awarded to him since I understand  
that to do so will be a sufficient ground for my disqualification as (Designation) in  
any future National Power Corporation bidding or employment with any Contractor doing  
business with the National Power Corporation.

\_\_\_\_\_  
(Name and Signature)  
AFFIANT

**[Jurat]**

**[Format shall be based on the latest Rules on Notarial Practice]**

One of the requirements from the bidder to be included in its Technical Envelope is a list of contractor's key personnel (viz. Project Manager, Project Engineer, Construction Safety Officer, Foreman, etc), to be assigned to the contract to be bid, with their complete qualification and experience data (including the key personnel's signed written commitment to work for the project once awarded the contract).

Standard Form Number: NPCSF-INFR-10b

**KEY PERSONNEL'S CERTIFICATE OF EMPLOYMENT  
(CONSTRUCTION SAFETY AND HEALTH OFFICER)**

\_\_\_\_\_  
Issuance Date

**THE PRESIDENT**  
National Power Corporation  
BIR Road cor. Quezon Ave.  
Diliman, Quezon City

Dear Sir:

I am (Name of Nominee) an Construction Safety & Health Officer with Certificate No. \_\_\_\_\_ issued on (date of issuance) at (place of issuance).

I hereby certify that (Name of Bidder) has engaged my services as Construction Safety & Health Officer for the (Name of Project), if awarded to it.

I am the Construction Safety & Health Officer of the following completed projects similar to the contract under bidding:

NAME OF PROJECT	OWNER	COST	DATE COMPLETED
_____	_____	_____	_____

At present, I am the Construction Safety & Health Officer of the following projects:

NAME OF PROJECT	OWNER	COST	DATE COMPLETED
_____	_____	_____	_____

In case of my separation for any reason whatsoever from the above-mentioned Contractor, I shall notify the National Power Corporation at least twenty one (21) days before the effective date of my separation.

As Construction Safety & Health Officer, I know I will have to stay in the job site all the time and aware that I am authorized to handle only one (1) contract at a time.

I do not allow the use of my name for the purpose of enabling the above-mentioned Contractor to qualify for the Contract without any firm commitment on my part to assume the post of Construction Safety & Health Officer, if the contract is awarded to him since I understand that to do so will be a sufficient ground for my disqualification as Construction Safety & Health Officer in any future National Power Corporation bidding or employment with any Contractor doing business with the National Power Corporation.

\_\_\_\_\_  
(Name and Signature)  
AFFIANT

**[Jurat]**

*[Format shall be based on the latest Rules on Notarial Practice]*

*One of the requirements from the bidder to be included in its Technical Envelope is a list of contractor's key personnel (viz. Project Manager, Project Engineer, Construction Safety Officer, Foremen, etc), to be assigned to the contract to be bid, with their complete qualification and experience data (including the key personnel's signed written commitment to work for the project once awarded the contract).*



Standard Form Number: NPCSF-INFR-11

**KEY PERSONNEL  
(FORMAT OF BIO-DATA)**

Give the detailed information of the following personnel who are scheduled to be assigned as full-time field staff for the project. Fill up a form for each person.

- 1. Name : \_\_\_\_\_
- 2. Date of Birth : \_\_\_\_\_
- 3. Nationality : \_\_\_\_\_
- 4. Education and Degrees : \_\_\_\_\_
- 5. Specialty : \_\_\_\_\_
- 6. Registration : \_\_\_\_\_
- 7. Length of Service with the Firm : \_\_\_\_\_ Year from \_\_\_\_\_ (months) \_\_\_\_\_ (year)  
To \_\_\_\_\_ (months) \_\_\_\_\_ (year)
- 8. Years of Experience : \_\_\_\_\_
- 9. If Item 7 is less than ten (10) years, give name and length of service with previous employers for a ten (10)-year period (attached additional sheet/s), if necessary:

Name and Address of Employer

Length of Service

_____	_____ year(s) from	_____ to
_____	_____ year(s) from	_____ to
_____	_____ year(s) from	_____ to

10. Experience:

This should cover the past ten (10) years of experience. (Attached as many pages as necessary to show involvement of personnel in projects using the format below).

*One of the requirements from the bidder to be included in its Technical Envelope is a list of contractor's key personnel (viz. Project Manager, Project Engineer, Construction Safety Officer, Foremen, etc), to be assigned to the contract to be bid, with their complete qualification and experience data (including the key personnel's signed written commitment to work for the project once awarded the contract).*

SECTION VIII – BIDDING FORMS

LuzP20Z1179Se

Standard Form Number: NPCSF-INFR-11  
 Page 2 of 2

1. Name : \_\_\_\_\_
2. Name and Address of Owner : \_\_\_\_\_
3. Name and Address of the  
 Owner's Engineer  
 (Consultant) : \_\_\_\_\_
4. Indicate the Features of Project  
 (particulars of the project  
 components and any other particular  
 interest connected with the project): \_\_\_\_\_
5. Contract Amount Expressed in  
 Philippine Currency : \_\_\_\_\_
6. Position : \_\_\_\_\_
7. Structures for which the employee  
 was responsible : \_\_\_\_\_
8. Assignment Period : from \_\_\_\_\_ (months) \_\_\_\_\_ (years)  
 : to \_\_\_\_\_ (months) \_\_\_\_\_ (years)

\_\_\_\_\_  
 Name and Signature of Employee

It is hereby certified that the above personnel can be assigned to this project, if the contract is awarded to our company.

\_\_\_\_\_  
 (Place and Date)

\_\_\_\_\_  
 (The Authorized Representative)

*One of the requirements from the bidder to be included in its Technical Envelope is a list of contractor's key personnel (viz. Project Manager, Project Engineer, Construction Safety Officer, Foremen, etc), to be assigned to the contract to be bid, with their complete qualification and experience data (including the key personnel's signed written commitment to work for the project once awarded the contract).*

Standard Form Number: NPCSF-INFR-12

**LIST OF EQUIPMENT, OWNED OR LEASED AND/OR UNDER PURCHASE AGREEMENTS**  
*(Based on the Minimum Equipment Required in the Bidding Documents)*

Business Name: \_\_\_\_\_  
 Business: \_\_\_\_\_

Description	Model/Year	Capacity / Performance / Size	Plate No.	Motor No. / Body No.	Location	Condition	Proof of Ownership / Lessor or Vendor
<b>A. Owned</b>							
i.							
ii.							
iii.							
iv.							
v.							
<b>B. Leased</b>							
i.							
ii.							
iii.							
iv.							
v.							
<b>C. Under Purchase Agreements</b>							
i.							
ii.							
iii.							
iv.							
v.							

Submitted by: \_\_\_\_\_  
 (Printed Name & Signature)

Designation: \_\_\_\_\_

Date: \_\_\_\_\_

*One of the requirements from the bidder to be included in its Technical Envelope is the list of its equipment units pledged for the contract to be bid, based on minimum equipment required in the bidding docs. which are owned (supported by proof/s of ownership), leased, and/or under purchase agreements (with corresponding engine numbers, chassis numbers and/or serial numbers), supported by certification of availability of equipment from the equipment lessor/vendor for the duration of the project*

Standard Form No. : NPCSF-INFR-13

**BID LETTER**

Date: \_\_\_\_\_

To: **THE PRESIDENT**  
 National Power Corporation  
 BIR Road cor. Quezon Ave.  
 Diliman, Quezon City

We, the undersigned, declare that:

(a) We have examined and have no reservation to the Bidding Documents, including Addenda, for the Contract **SUPPLY, DELIVERY, INSTALLATION AND TEST OF 1 X 35 KL AND 2 X 60 KL FOST FOR PATNANUNGAN DPP, PALANAN DPP AND JOMALIG DPP INCLUDING CONSTRUCTION OF ASSOCIATED FACILITIES UNDER PACKAGE 1 (LuzP20Z1179Se).**

(b) We offer to execute the Works for this Contract in accordance with the Bid Documents, Technical Specifications, General and Special Conditions of Contract accompanying this Bid;

The total price of our Bid, excluding any discounts offered below is: [insert information] \_\_\_\_\_;

The discounts offered and the methodology for their application are: [insert information] \_\_\_\_\_;

(c) Our Bid shall be valid for a period of [insert number] \_\_\_\_\_ days from the date fixed for the Bid submission deadline in accordance with the Bidding Documents, and it shall remain binding upon us and may be accepted at any time before the expiration of that period;

(d) If our Bid is accepted, we commit to obtain a Performance Security in the amount of [insert percentage amount] \_\_\_\_\_ percent of the Contract Price for the due performance of the Contract;

(e) Our firm, including any subcontractors or suppliers for any part of the Contract, have nationalities from the following eligible countries: [insert information] \_\_\_\_\_;

(f) We are not participating, as Bidders, in more than one Bid in this bidding process, other than alternative offers in accordance with the Bidding Documents;

(g) Our firm, its affiliates or subsidiaries, including any subcontractors or suppliers for any part of the Contract, has not been declared ineligible by the Funding Source;

(h) We understand that this Bid, together with your written acceptance thereof included in your notification of award, shall constitute a binding contract between us, until a formal Contract is prepared and executed; and

(i) We understand that you are not bound to accept the Lowest Calculated Bid or any other Bid that you may receive.

- (j) We likewise certify/confirm that the undersigned, is the duly authorized representative of the bidder, and granted full power and authority to do, execute and perform any and all acts necessary to participate, submit the bid, and to sign and execute the ensuing contract for the **SUPPLY, DELIVERY, INSTALLATION AND TEST OF 1 X 35 KL AND 2 X 60 KL FOST FOR PATNANUNGAN DPP, PALANAN DPP AND JOMALIG DPP INCLUDING CONSTRUCTION OF ASSOCIATED FACILITIES UNDER PACKAGE 1 (LuzP20Z1179Se)** of the National Power Corporation.
- (k) We acknowledge that failure to sign each and every page of this Bid Letter, including the Bill of Quantities, shall be a ground for the rejection of our bid.

Name: \_\_\_\_\_

In the capacity of: \_\_\_\_\_

Signed: \_\_\_\_\_

Duly authorized to sign the Bid for and on behalf of: \_\_\_\_\_

Date: \_\_\_\_\_

Standard Form No. : NPCSF-INFR-14

**DETAILED COST ESTIMATE FORM**

Name of Bidder : \_\_\_\_\_

Item No.	Item Description	Unit of Measure	Direct Cost			Mark-Up		VAT	Unit Cost	Total Price
			Materials	Labor	Equipment	OCM	Profit			

\_\_\_\_\_ Name, Signature of Authorized Representative

\_\_\_\_\_ Designation

Standard Form No. : NPCSF-INFR-15

**SUMMARY SHEETS OF MATERIALS PRICES, LABOR RATES  
 AND EQUIPMENT RENTAL RATES**

Name of Bidder : \_\_\_\_\_  
 \_\_\_\_\_

**I. Unit Prices of Materials**

Materials Description	Unit	Unit Price
1.		
2.		
3.		
4.		
5.		
6.		
7.		

**II. Manpower Hourly Rates**

Designation	Rate/Hr.
1.	
2.	
3.	
4.	
5.	
6.	
7.	

**III. Equipment Hourly Rental Rates**

Equipment Description	Rental Rate/Hr.
1.	
2.	
3.	
4.	
5.	
6.	
7.	

\_\_\_\_\_  
 Name, Signature of Authorized Representative

\_\_\_\_\_  
 Designation

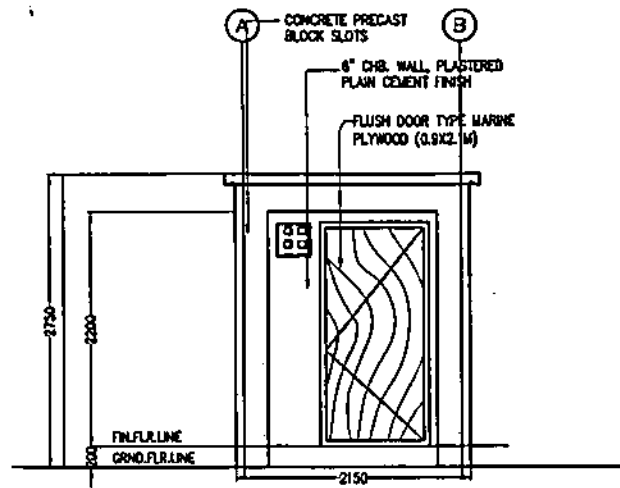

FRONT ELEVATION

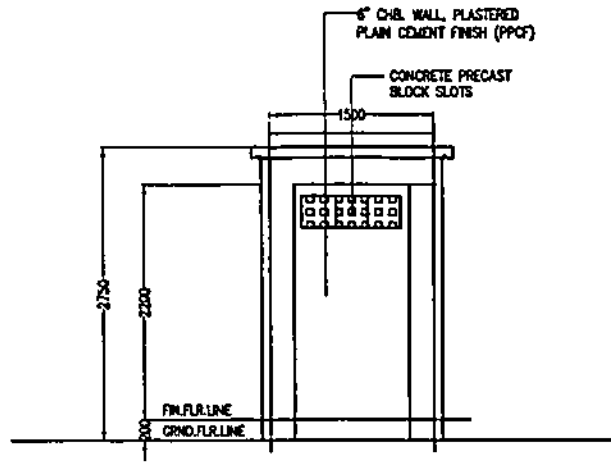

SIDE ELEVATIONS

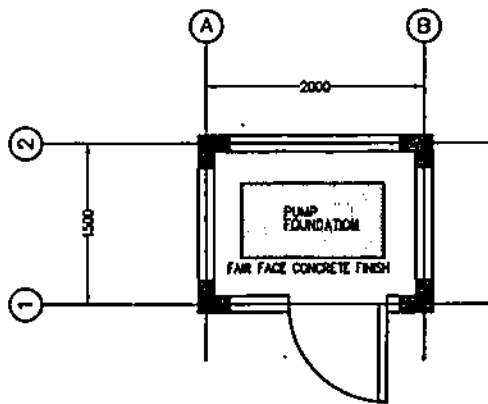

P L A N

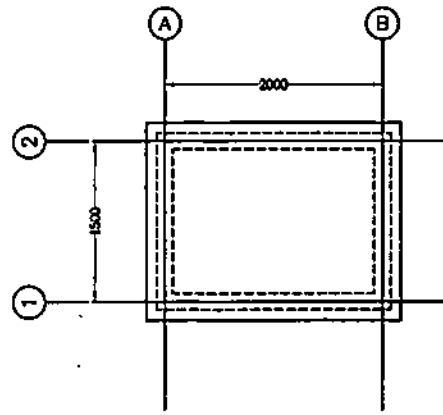

ROOF PLAN

**NOTES:**

1. ALL DIMENSIONS & ELEVATIONS ARE IN METERS UNLESS OTHERWISE SPECIFIED.
2. WORK THIS DRAWING WITH MECHANICAL DRAWINGS.

OWNER:		 <b>NATIONAL POWER CORPORATION</b> AGHAM ROAD, DILIMAN, QUEZON CITY	
PROJECT: SUPPLY, DELIVERY, INSTALLATION AND TEST OF 1008 KL AND 2008 KL POST FOR PATNABUNGAN DPP, PALAMAS DPP, AND JORALIS DPP INCLUDING CONSTRUCTION OF ASSOCIATED FACILITIES UNDER PACKAGE 1 LOCATION: VARIOUS AREAS IN QUEZON			
TITLE: <b>PUMPHOUSE (PLAN &amp; ELEVATIONS)</b>			
DESIGNED	BY	CHKD	DATE
DRAWN	DATE		
REVIEWED	PRINCIPAL ENGR./ARCHT.	RECOMMENDED	
OVERSIGHT		APPROVED:	
ELEC.			
MECH.			
DWG. NO. <b>PKG1-BDA-17.001</b>		SPEC. NO. <b>L1UZP20Z1179S@</b>	
SCALE: 1:50		<b>BID DRAWING</b>	
REV. DATE		NATURE OF REVISION	
BY	CHKD.	RECD.	APPR.

REV.	DATE	NATURE OF REVISION	BY	CHKD.	RECD.	APPR.



**SECTION IX – BID DRAWINGS****CW – CIVIL WORKS**

<b><u>DRAWING NO.</u></b>	<b><u>TITLE</u></b>
JomDPP-BDC-17.001	SITE DEVELOPMENT PLAN (1 X 60 KL FOST Jomalig DPP)
JomDPP-BDC-17.002	60 CU.M. FUEL OIL STORAGE TANK (Plan and Section)
JomDPP-BDC-17.003	60 CU.M. FUEL OIL STORAGE TANK (Plan and Details)
JomDPP-BDC-17.004	DRAIN PIT, VALVE BOX AND DRAINAGE DITCH (Plan, Section & Details)
JomDPP-BDC-17.005	CONTAINMENT WALL AND LADDER RUNG (Plan, Section Details)
JomDPP-BDC-17.006	OIL WATER SEPARATOR (Plan, Section Details)
PatDPP-BDC-17.001	SITE DEVELOPMENT PLAN (1 X 35 KL FOST Patnanungan DPP)
PatDPP-BDC-17.002	35 CU.M. FUEL OIL STORAGE TANK (Plan and Section)
PatDPP-BDC-17.003	35 CU.M. FUEL OIL STORAGE TANK (Plan and Details)
PatDPP-BDC-17.004	DRAIN PIT, VALVE BOX AND DRAINAGE DITCH (Plan, Section & Details)

## SECTION IX – BID DRAWINGS

LuzP20Z1179Sa

PatDPP-BDC-17.005	CONTAINMENT WALL AND LADDER RUNG (Plan, Section Details)
PaIDPP-BDC-17.001	SITE DEVELOPMENT PLAN (1 X 35 KL FOST Patnanungan DPP)
PaIDPP-BDC-17.002	35 CU.M. FUEL OIL STORAGE TANK (Plan and Section)
PaIDPP-BDC-17.003	35 CU.M. FUEL OIL STORAGE TANK (Plan and Details)
PaIDPP-BDC-17.004	DRAIN PIT, VALVE BOX AND DRAINAGE DITCH (Plan, Section & Details)
PaIDPP-BDC-17.005	CONTAINMENT WALL AND LADDER RUNG (Plan, Section Details)
PaIDPP-BDC-17.006	OIL WATER SEPARATOR (Plan, Section Details)
PaIDPP-BDC-17.007	DRAINAGE APPURTENANCES (Ditch Plan & Section)
PKG1-BDC-17.001	PUMPHOUSE (Foundation Plan, Section and Details)
PKG1-BDC-17.002	PUMPHOUSE (Roof Beam & Roof Slab, Section, Details)

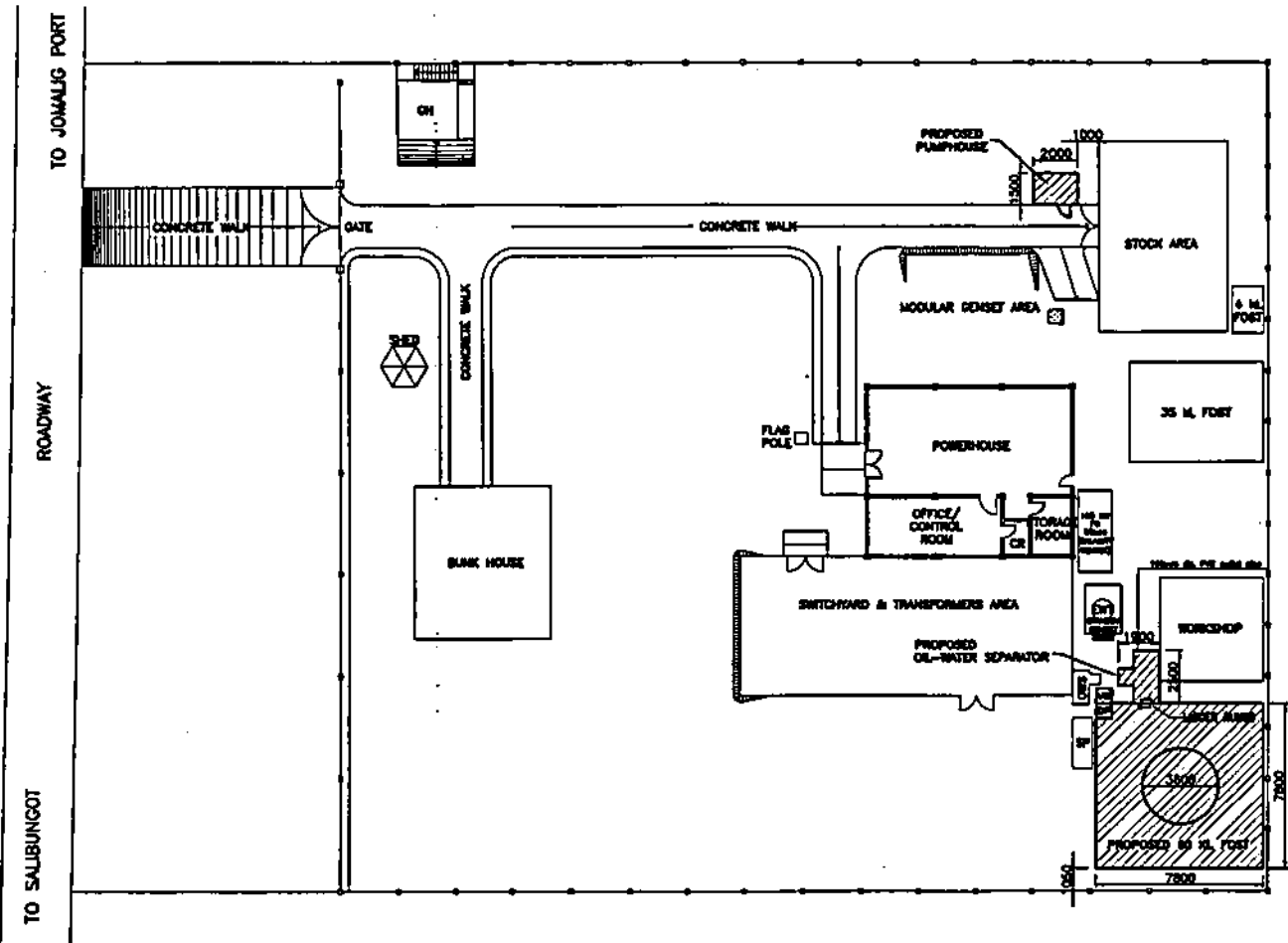

**SITE DEVELOPMENT PLAN**  
SCALE 1:250

- LEGEND:**
- - EXISTING EQUIPMENT/FACILITY
  - ▨ - PROPOSED EQUIPMENT/FACILITY
  - DP - DRAIN PIT
  - OWS - OIL-WATER SEPARATOR
  - VB - VALVE BOX
  - SP - SUM PIT

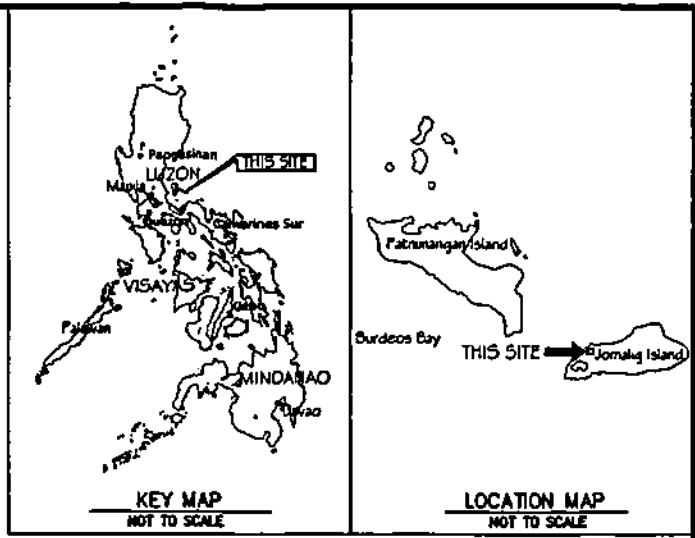

**GENERAL CONSTRUCTION NOTES:**

1. ALL DIMENSIONS ARE IN MILLIMETERS UNLESS OTHERWISE INDICATED
2. MINIMUM COMPRESSIVE STRENGTH OF CONCRETE SHALL BE  $f_{cm} = 20.7 \text{ MPa}$  (3000 psi) AT 28-DAY PERIOD.
3. REINFORCING STEEL BARS SHALL CONFORM TO THE REQUIREMENTS OF THE PNS FOR DEFORMED STEEL BARS.
4. DETAILS OF REINFORCING BARS (SPICES, BENDS, HOOKS, ETC.) SHALL BE IN ACCORDANCE WITH THE REQUIREMENTS OF ACI CODE.
5. ALL STRUCTURAL STEEL SHALL CONFORM TO THE REQUIREMENTS OF ASTM A36.
6. ALL BOLTED CONNECTIONS SHALL BE MADE USING HIGH STRENGTH BOLTS, NUTS AND WASHERS CONFORMING TO ASTM A325.
7. ALL WELDING WORKS SHALL CONFORM TO E70XX SERIES OF SPECIFICATIONS FOR MILD STEEL ARC WELDING ELECTRODES ASTM A233.
8. ALLOWABLE BEARING CAPACITY OF SOIL SHALL NOT BE LESS THAN 143.9  $\text{KPa}$ .
9. THE SUPPLIER/CONTRACTOR SHALL SUBMIT CERTIFIED TEST REPORTS (MILL TEST OR OTHER) AND SHOP DRAWINGS FOR NPC'S REVIEW AND APPROVAL PRIOR TO FABRICATION WORKS.

OWNER:				<b>NATIONAL POWER CORPORATION</b> AGHAM ROAD, DILIMAN QUEZON CITY	
PROJECT: SUPPLY, DELIVERY, INSTALLATION AND TEST OF 1000 KL AND 2000 KL FOST FOR PATMANGANG DDP, PALAMANG DDP, AND JOMALIG DDP INCLUDING CONSTRUCTION OF ASSOCIATED FACILITIES UNDER PACKAGE 1					
LOCATION: JOMALIG, QUEZON					
TITLE:		<b>SITE DEVELOPMENT PLAN</b> (1X60 KL FOST, JOMALIG DDP)			
DESIGNED	BY	CHKD	DATE	SUBMITTED	<b>H. L. MENDOZA</b>
DRAWN				RECOMMENDED	<b>V. TORVINA</b>
REVIEWED	PRINCIPAL ENGR. / ARCHT.			APPROVED	<b>G. B. MAGPOC JR.</b>
ENLARGED				Manager, DDO	
ELEC.					
MECH.					
OWR. NO. JomDPP-BDC-17.001			SPECS. NO. LUZP20Z1179S		
REV.	DATE	NATURE OF REVISION	BY	CHKD	RECD.

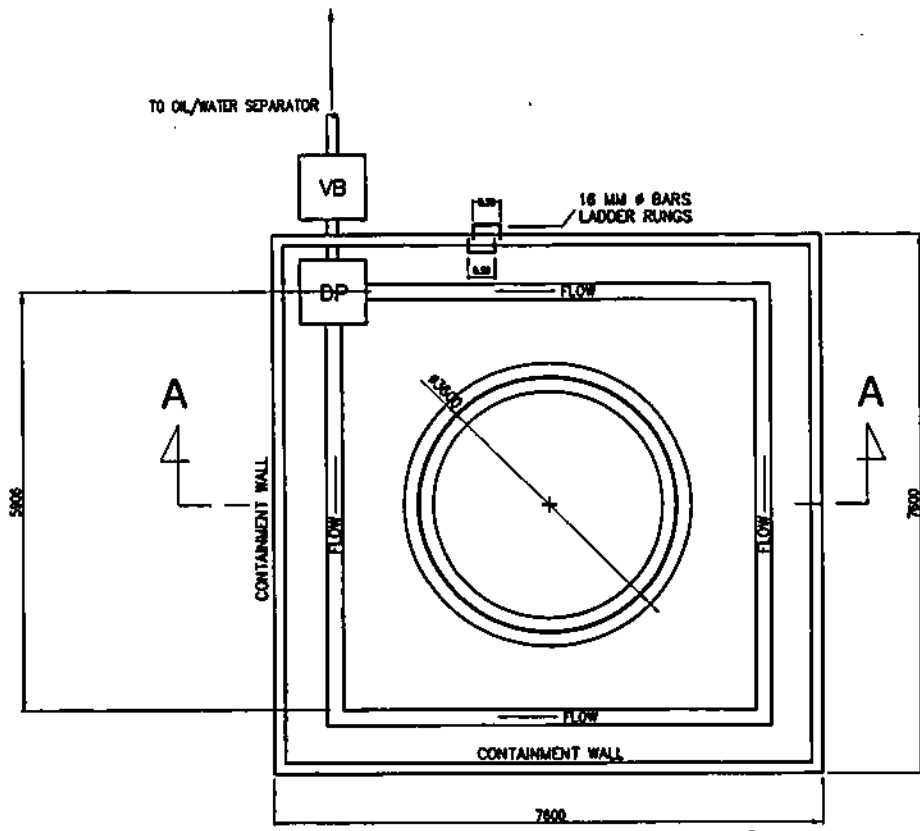

**PLAN**  
SCALE 1:75

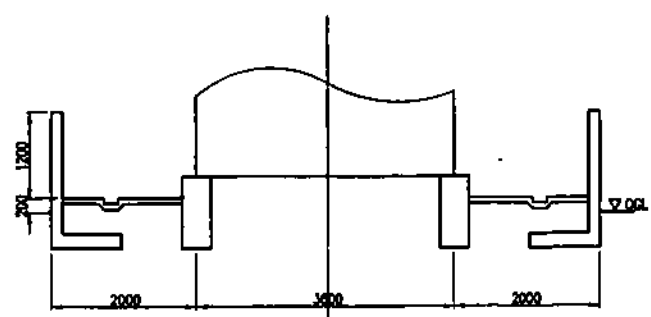

**SECTION THRU A**  
SCALE 1:75

**LEGEND:**

- DP - DRAIN PIT
- VB - VALVE BOX

**NOTES:**

1. ALL DIMENSIONS ARE IN MILLIMETERS UNLESS OTHERWISE INDICATED.
6. WORK THIS WITH MECHANICAL DRAWINGS.

OWNER		 <b>NATIONAL POWER CORPORATION</b> AGHAM ROAD, DILIMAN, QUEZON CITY	
PROJECT: SUPPLY, DELIVERY, INSTALLATION AND TEST OF 1235 KL AND 2320 KL POND FOR PATUNGARANG DDP, PALARAN DDP, AND JORALIN DDP INCLUDING CONSTRUCTION OF ASSOCIATED FACILITIES UNDER PACKAGE 1			
LOCATION: JORALIN, QUEZON			
TITLE <b>60 CU.M. FUEL OIL STORAGE TANK</b> (PLAN & SECTION)			
DESIGNED	BY	CHKD	DATE
DRAWN	DATE		
REVIEWED	PRINCIPAL ENGR./ ARCHT.	RECOMMENDED	
CIVIL/ARCHT			
ELEC.		APPROVED:	
MECH.			
DWG NO JomDPP-BDC-17.002		SPEC NO LuzP20Z/179S	
SCALE AS SHOWN		81D DRAWING	

REV.	DATE	NATURE OF REVISION	BY	CHKD	SECD	APPD.

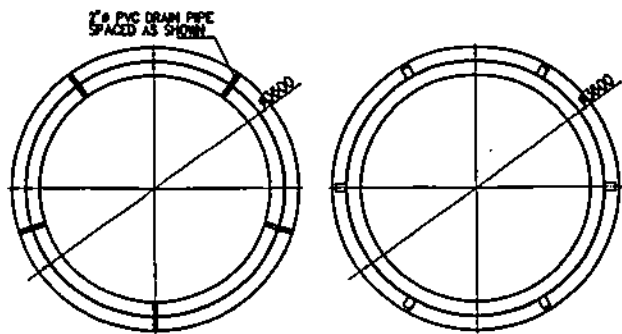

**DRAIN PLAN**  
SCALE 1:75

**PLAN (BLOCKOUTS)**  
SCALE 1:75

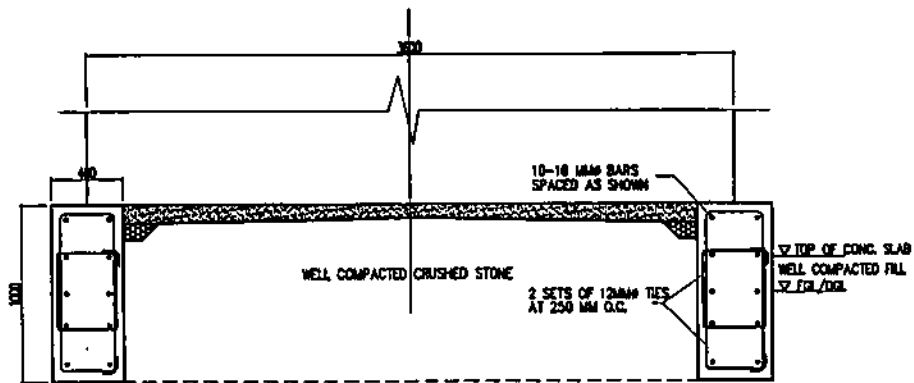

**FOUNDATION (SECTION)**  
SCALE 1:30

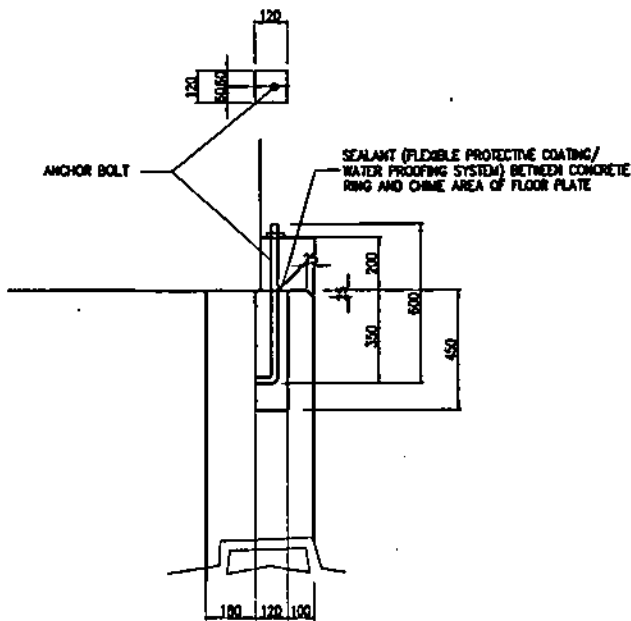

**BLOCKOUT DETAILS**  
SCALE 1:20

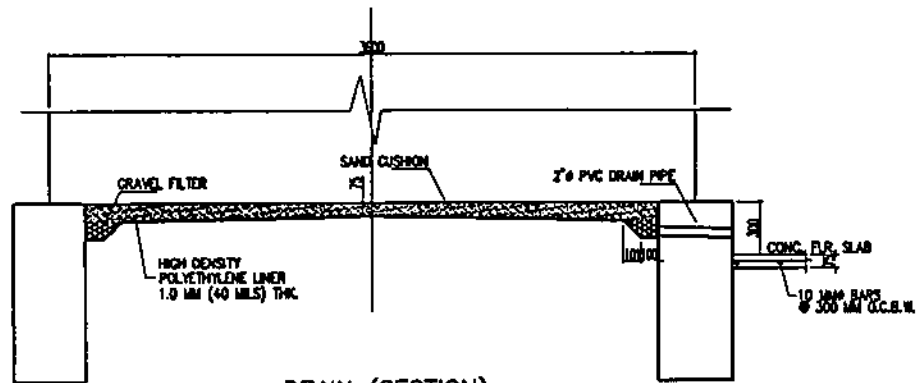

**DRAIN (SECTION)**  
SCALE 1:30

**NOTES:**

1. ALL DIMENSIONS ARE IN MILLIMETERS UNLESS OTHERWISE INDICATED.
2. MINIMUM COMPRESSIVE STRENGTH OF CONCRETE IS  $f_c = 20.7 \text{ MPa}$  (3,000 psi).
3. REINFORCING STEEL BARS SHALL CONFORM TO THE REQUIREMENTS OF THE PHILIPPINE NATIONAL STANDARD (LATEST EDITION) FOR DEFORMED BARS GRADE 275.
4. ASSUMED ALLOWABLE BEARING CAPACITY IS 180 KPa WITHOUT THE PRESENCE OF WATER TABLE.
5. FINAL LAYOUT AND DETAILS OF ANCHOR BOLTS AND TANK SHELL PLATE INCLUDING ALL MECHANICAL AND PIPING SYSTEMS WILL BE REFERRED TO RELEVANT MECHANICAL DRAWINGS.
6. PVC DRAIN PIPES SHALL BE PROVIDED WITH DEPENDABLE SCREENS TO HOLD THE GRAVEL FILTER FROM PASSING THROUGH.
7. ALL ANCHOR BOLT BLOCKOUTS SHALL BE FILLED WITH CEMENT GROUT.
8. WORK THIS DRAWING WITH MECHANICAL DRAWINGS.

OWNER:	<b>NATIONAL POWER CORPORATION</b> AGHAM ROAD, DILIMAN, QUEZON CITY		
PROJECT:	SUPPLY, DELIVERY, INSTALLATION AND TEST OF 1226 HL AND 2326 HL PUMP FOR PATARUKULAN DDP, PALANAN DDP, AND JOMALIG DDP INCLUDING CONSTRUCTION OF ASSOCIATED FACILITIES UNDER PACKAGE 1		
LOCATION:	JOMALIG, QUEZON		
TITLE:	<b>60 CU.M. FUEL OIL STORAGE TANK</b> <b>(PLAN &amp; DETAILS)</b>		
DESIGNED BY:	CHKD BY:	DATE:	SUBMITTER: <b>H. L. MENDOZA</b> RECOMMENDED BY: <b>M. J. JORVINA</b> APPROVED: <b>C. S. MAGSINO, JR.</b>
DRAWN BY:	CHKD BY:	DATE:	
REVIEWED BY:	PRINCIPAL ENGR. / ARCHT.:	DATE:	
CHECKED BY:	DATE:	DATE:	
ELEC.:	DATE:	DATE:	
MEDL.:	DATE:	DATE:	

DWG NO. **JomDPP-BDC-17.003** SPEC NO. **LuzP202117593**

REV.	DATE	NATURE OF REVISION	BY	CHKD	DATE	APPD

SCALE AS SHOWN **BID DRAWING**

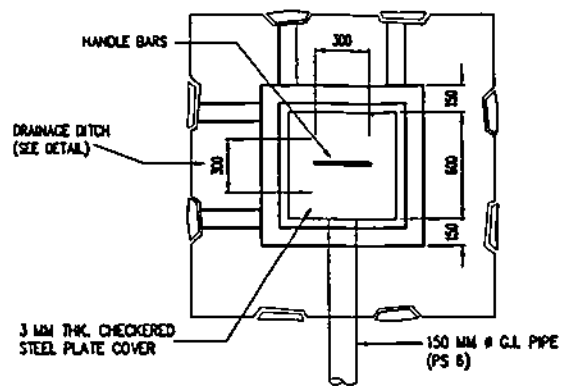

**PLAN**

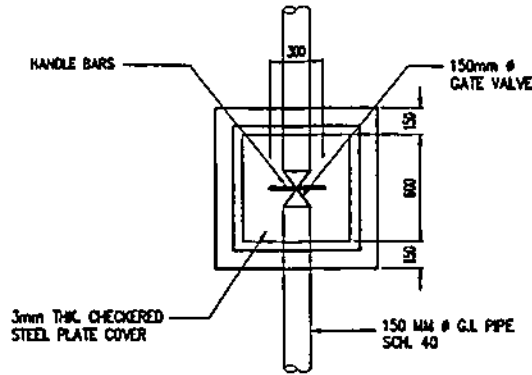

**PLAN**

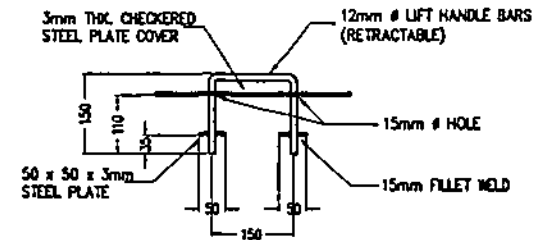

**HANDLE BAR DETAIL**

SCALE 1:10

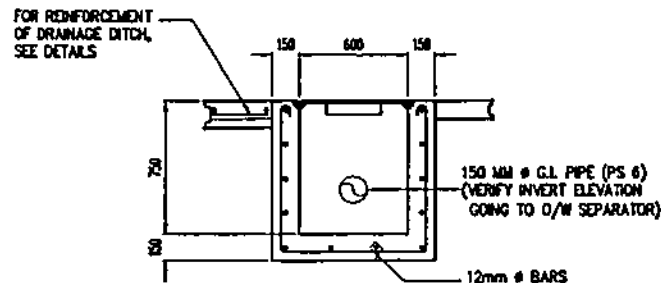

**SECTION**

**DRAIN PIT DETAIL**

SCALE 1:30

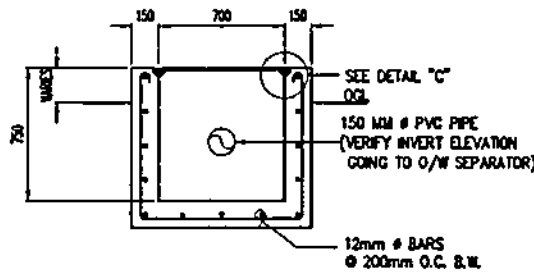

**SECTION**

**VALVE BOX DETAIL**

SCALE 1:30

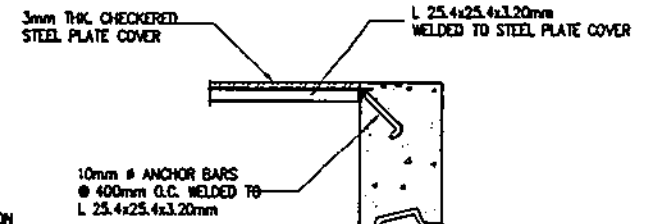

**DETAIL - C**

SCALE 1:10

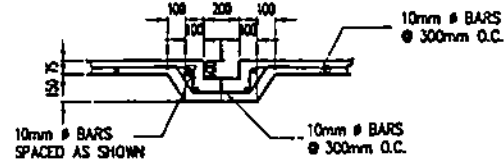

**DRAINAGE DITCH DETAIL**

SCALE 1:30

OWNER:				<b>NATIONAL POWER CORPORATION</b> AGHAM ROAD, DILIMAN, QUEZON CITY	
PROJECT: SUPPLY, DELIVERY, INSTALLATION AND TEST OF 1338 KL AND 2400 KL POND FOR PATRASMURDIP DDP, PALAMAS OFF. AND JORNALIS DIPP INCLUDING CONSTRUCTION OF ASSOCIATED FACILITIES UNDER PACKAGE 1					
LOCATION: JORNALIS, QUEZON					
TITLE: <b>DRAIN PIT, VALVE BOX &amp; DRAINAGE DITCH (PLAN, SECTION &amp; DETAILS)</b>					
DESIGNED BY	CHKD	DATE	SUBMITTED	H. L. SENDOZA	
DRAWN	DIMM			J. L. TORVINA	
REVIEWED	PRINCIPAL ENGINEER / ARCHT.		RECOMMENDED	G. B. MADRAGA JR.	
CALCULATED			APPROVED	G. B. MADRAGA JR.	
ELEC					
MECH					
DWS No. JomDPP-BDC-17.004			SPEC No. LuzP202/117/154		
REV.	DATE	NATURE OF REVISION	BY	CHKD	DATE
SCALE AS SHOWN			BID DRAWING		

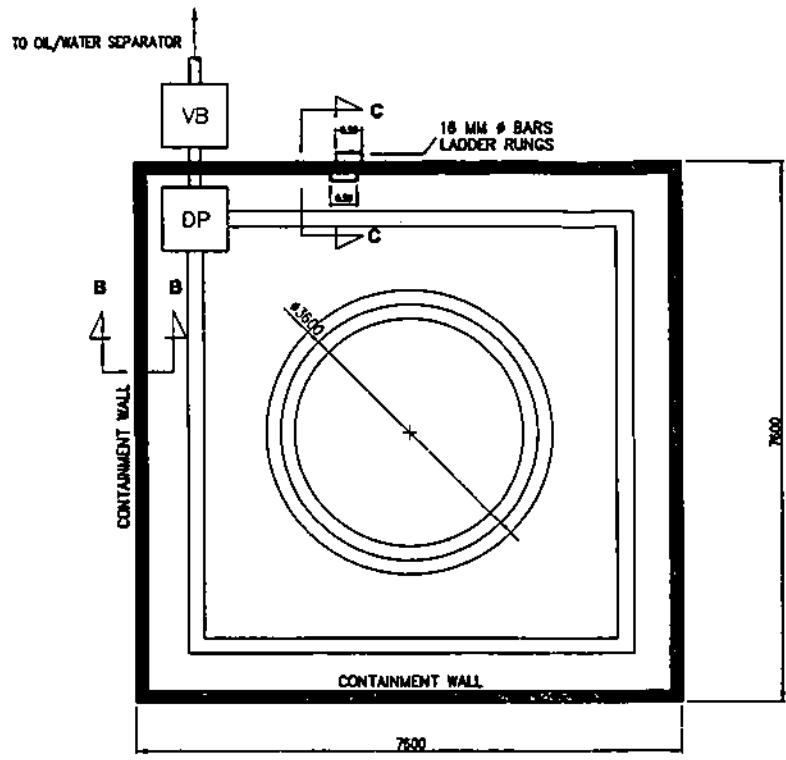

**CONTAINMENT WALL LAYOUT**

SCALE 1:75

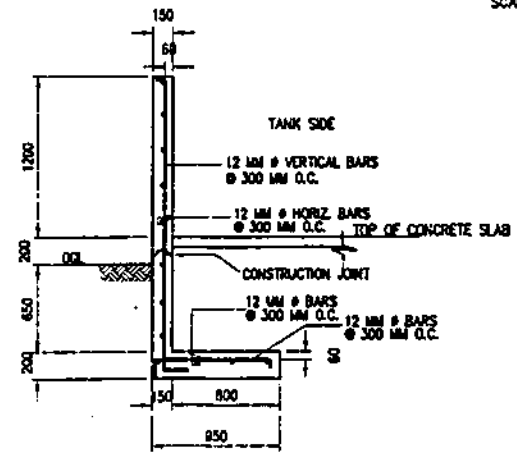

**SECTION B-B**

SCALE 1:40

**CONTAINMENT WALL SECTION**

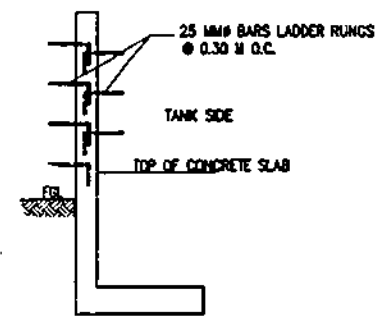

**SECTION C-C**

SCALE 1:40

**LADDER RUNG SECTION**

**NOTES:**

1. ALL DIMENSIONS & ELEVATIONS ARE IN METERS UNLESS OTHERWISE SPECIFIED.
2. MINIMUM COMPRESSIVE STRENGTH OF CONCRETE SHALL BE  $f_c = 20.70 \text{ MPa}$  AT 28 DAYS PERIOD.
3. ALL REINFORCING BARS SHALL CONFORM TO THE LATEST REQUIREMENTS OF PHS FOR DSB GRADE 275.
4. PROVIDE PVC WATERSTOP (6"±3/16" PLAN DUMBBELL TYPE) AT CONSTRUCTION JOINT.
5. ALL ASPECTS OF CONSTRUCTION AND DETAILING OF REINFORCEMENTS SHALL BE IN ACCORDANCE WITH THE LATEST EDITION OF THE ACI CODE.

OWNER:		 <b>NATIONAL POWER CORPORATION</b> AGHAM ROAD, DELIMAN, QUEZON CITY	
PROJECT: SUPPLY, DELIVERY, INSTALLATION AND TEST OF 1026 KG. AND 2308 KG. PORT FOR PATRANGUNGAN DPP, PALANAN DPP, AND JOMALIG DPP INCLUDING CONSTRUCTION OF ASSOCIATED FACILITIES UNDER PACKAGE 1			
LOCATION: JOMALIG, QUEZON			
TITLE: <b>CONTAINMENT WALL AND LADDER RUNG (PLAN, SECTION &amp; DETAILS)</b>			
DESIGNED	BY	CHKD	DATE
DRAWN	DATE	SUBMITTED: <i>H. L. MENDOZA</i>	
REVIEWED	PRINCIPAL ENGR. / ARCHT.	RECOMMENDED: <i>S. JORVINA</i>	
CIVIL/ARCHT	APPROVED: <i>G. B. MAGPOC, JR.</i>		
ELEC	MECH		
Dwg No. JomDPP-BDC-17.005		Spec. No. LuzP20Z1179S	
SCALE AS SHOWN		BIG DRAWING	

REV	DATE	NATURE OF REVISION	BY	CHKD	RECD	APPD

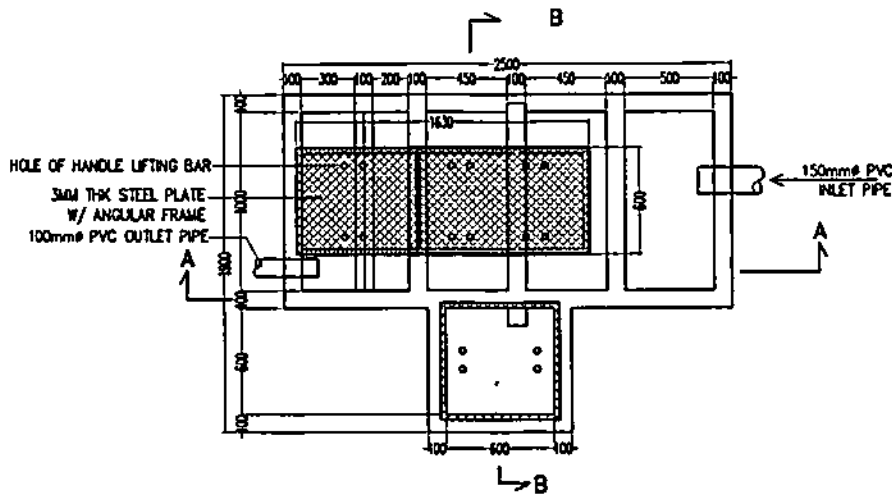

**PLAN**  
SCALE 1:30

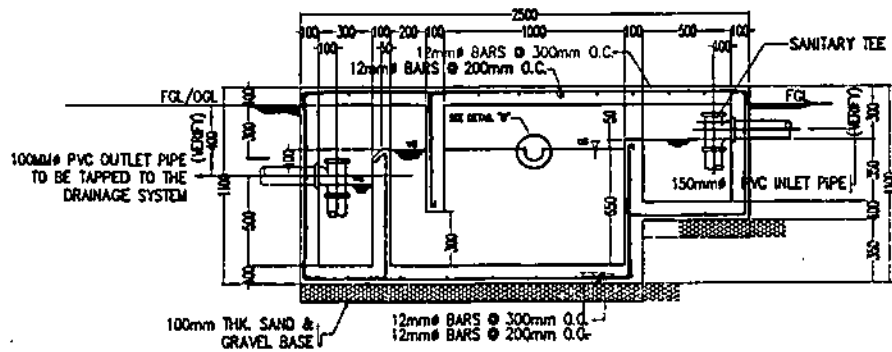

**SECTION A-A**  
SCALE 1:30

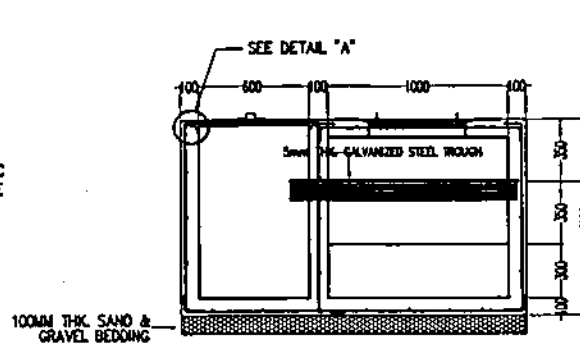

**SECTION B-B**  
SCALE 1:30



**DETAIL "A"**  
NOT TO SCALE

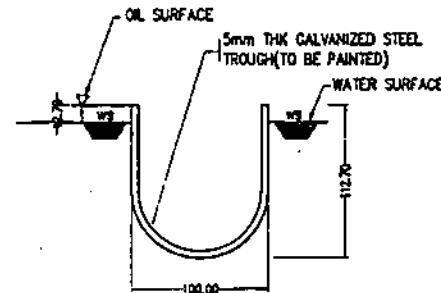

**DETAIL "B"**  
SCALE 1:4

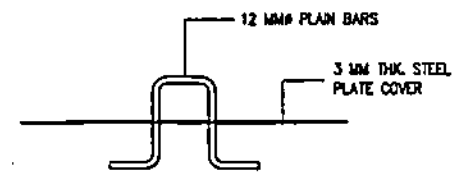

**DETAIL OF LIFTING HANDLE BAR**  
SCALE 1:10

**NOTES:**

1. ALL DIMENSIONS AND ELEVATIONS ARE IN MILLIMETERS UNLESS OTHERWISE INDICATED.
2. MINIMUM COMPRESSIVE STRENGTH OF CONCRETE SHALL BE  $f_c=20.70 \text{ MPa}$  AT 28 DAY PERIOD.
3. ALL REINFORCING STEEL BARS SHALL CONFORM TO THE LATEST REQUIREMENTS OF PNS FOR DEFORMED STEEL BARS, GRADE 275.
4. ALL ASPECTS OF CONSTRUCTION AND DETAILING OF REINFORCEMENTS SHALL BE IN ACCORDANCE WITH THE PROVISIONS OF ACI CODE.
5. BEFORE THE START OF THE CONSTRUCTION, VERIFY THE DRAINAGE STRUCTURES & ELEVATIONS CONNECTED TO THE OIL-WATER SEPARATOR.
6. AFTER THE COMPLETION OF THE CONSTRUCTION, THE OIL-WATER SEPARATOR MUST BE FILLED WITH WATER UP TO THE BOTTOM RIM OF THE STEEL TROUGH.

OWNER:		<b>NATIONAL POWER CORPORATION</b> AGHAM ROAD, DILIMAN, QUEZON CITY	
PROJECT: SUPPLY, DELIVERY, INSTALLATION AND TEST OF 12M KL AND 24M KL FOST FOR PATABUNGAM DPP, PALAMAM DPP, AND JOZALAN DPP INCLUDING CONSTRUCTION OF ASSOCIATED FACILITIES UNDER PACKAGE 1			
LOCATION: JOMALAN, QUEZON			
TITLE: <b>OIL WATER SEPARATOR (PLAN, SECTIONS &amp; DETAILS)</b>			
DESIGNED	BY	CHKD	DATE
DRAWN	DASH		
REVIEWED	PRINCIPAL ENGR / ARCHT.	RECOMMENDED	
CIVIL/ARCHT			
ELEC		APPROVED	
MECH			
DWO NO. JomDPP-BDC-17.006		SPEC NO. LuzP20Z117930	
SCALE AS SHOWN		BID DRAWING	

REV	DATE	NATURE OF REVISION	BY	CHKD	SCALE	APPD



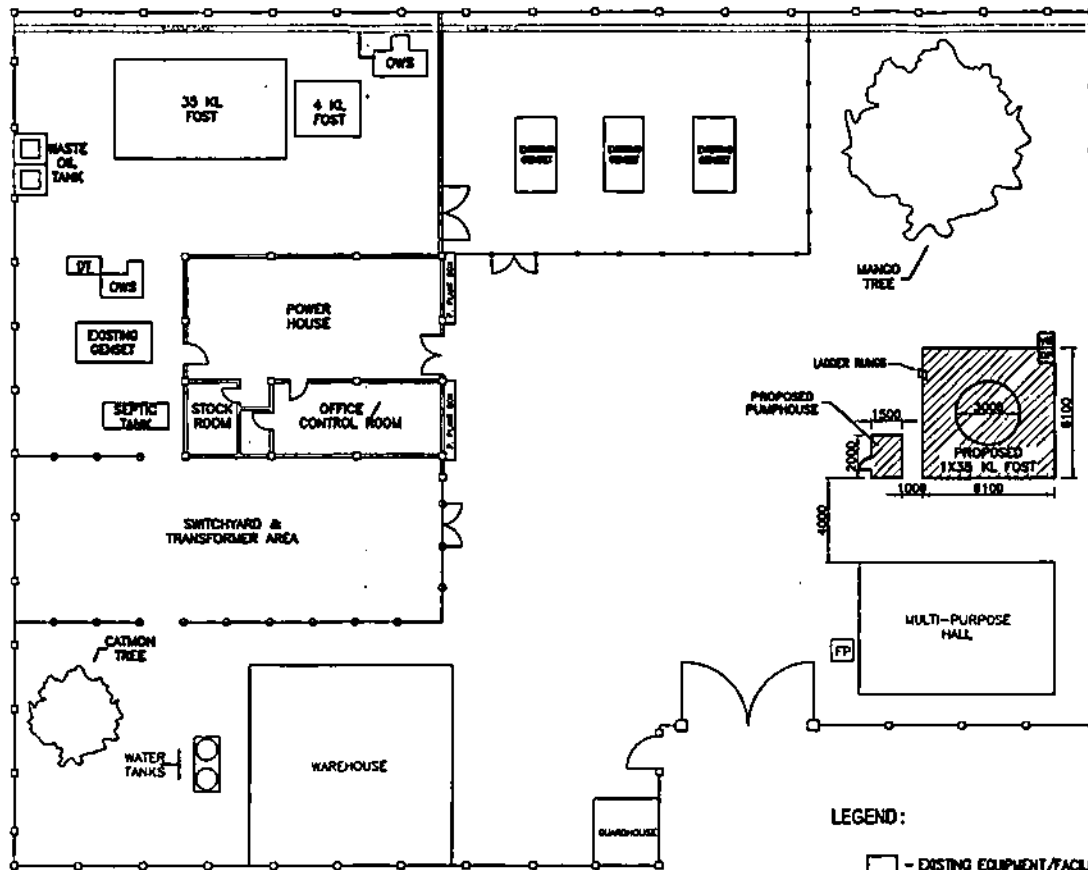

**SITE DEVELOPMENT PLAN**  
SCALE 1:250

**LEGEND:**

- - EXISTING EQUIPMENT/FACILITY
- ▨ - PROPOSED EQUIPMENT/FACILITY
- DP - DRAIN PIT
- OWS - OIL-WATER SEPARATOR
- VB - VALVE BOX
- DT - DAY TANK
- FP - FLAG POLE

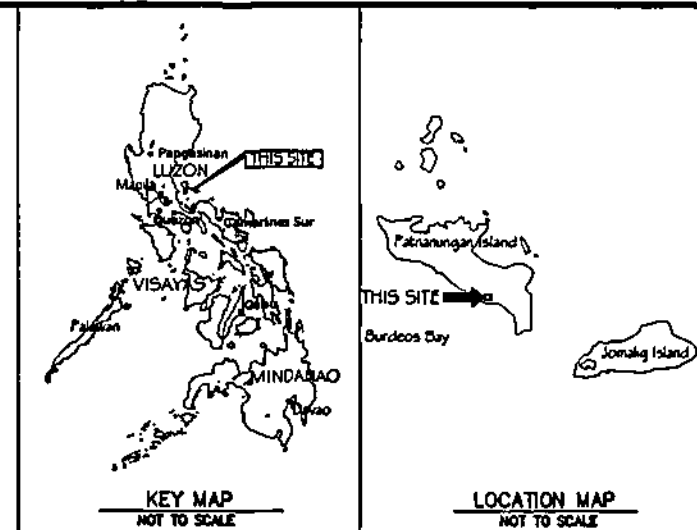

**GENERAL CONSTRUCTION NOTES:**

1. ALL DIMENSIONS ARE IN MILLIMETERS UNLESS OTHERWISE INDICATED
2. MINIMUM COMPRESSIVE STRENGTH OF CONCRETE SHALL BE  $f_c = 20.7 \text{ MPa}$  (3000 psi) AT 28-DAY PERIOD.
3. REINFORCING STEEL BARS SHALL CONFORM TO THE REQUIREMENTS OF THE PNS FOR DEFORMED STEEL BARS.
4. DETAILS OF REINFORCING BARS (SPICES, BENDS, HOOKS, ETC.) SHALL BE IN ACCORDANCE WITH THE REQUIREMENTS OF ACI CODE.
5. ALL STRUCTURAL STEEL SHALL CONFORM TO THE REQUIREMENTS OF ASTM A36.
6. ALL BOLTED CONNECTIONS SHALL BE MADE USING HIGH STRENGTH BOLTS, NUTS AND WASHERS CONFORMING TO ASTM A325.
7. ALL WELDING WORKS SHALL CONFORM TO E70XX SERIES OF SPECIFICATIONS FOR MILD STEEL ARC WELDING ELECTRODES ASTM A233.
8. ALLOWABLE BEARING CAPACITY OF SOIL SHALL NOT BE LESS THAN 143.9 KPa.
9. THE SUPPLIER/CONTRACTOR SHALL SUBMIT CERTIFIED TEST REPORTS (MILL TEST OR OTHER) AND SHOP DRAWINGS FOR NPC'S REVIEW AND APPROVAL PRIOR TO FABRICATION WORKS.

OWNER:		<b>NATIONAL POWER CORPORATION</b> AGHAM ROAD, DILIMAN QUEZON CITY	
PROJECT: SUPPLY, DELIVERY, INSTALLATION AND TEST OF 1X35 KL AND 2000 KL FOST FOR PATNANUNGAN DPP, PALAMAN DPP, AND JOMALIG DPP INCLUDING CONSTRUCTION OF ASSOCIATED FACILITIES UNDER PACKAGE 1 LOCATION: PATNANUNGAN, QUEZON			
TITLE: <b>SITE DEVELOPMENT PLAN</b> (1X35 KL FOST PATNANUNGAN DPP)			
DESIGNED BY	CHD	DATE	SUBMITTED: <i>M. L. MENDOZA</i> <i>Principal Engr. / ARCHT.</i> RECOMMENDED: <i>V. JORVINA</i> <i>Principal Engr. / ARCHT.</i> APPROVED: <i>G. B. MAGPOC, JR.</i> <i>Manager, DDO</i>
DRAWN BY			
REVIEWED BY	PRINCIPAL ENGR. / ARCHT.		
CHECKED BY			
ELEC. BY			
MECH. BY			
DWG. NO. <b>PatDPP-BOC-17.001</b>		SPECS. NO. <b>L12P2021179S</b>	

REV.	DATE	NATURE OF REVISION	BY	CHKD	RECD	APPR

SCALE: 1:250 **BID DRAWING** REV. 0

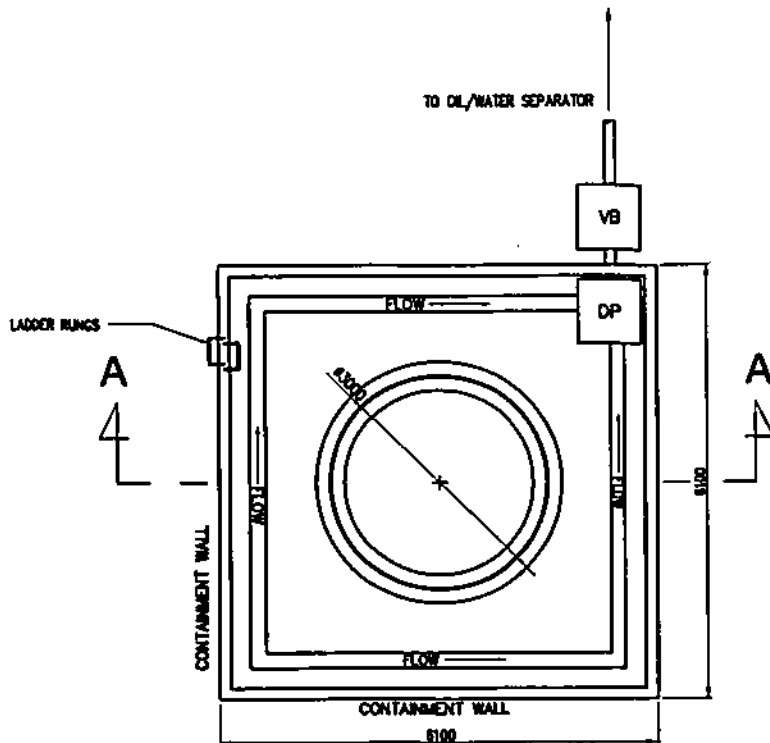

**PLAN**

SCALE 1:75

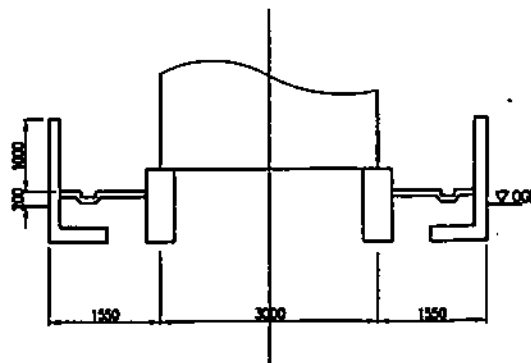

**SECTION THRU A**

SCALE 1:75

**LEGEND:**

DP - DRAIN PIT  
VB - VALVE BOX

**NOTES:**

1. ALL DIMENSIONS ARE IN MILLIMETERS UNLESS OTHERWISE INDICATED.
2. WORK THIS WITH MECHANICAL DRAWINGS.

OWNER:				<b>NATIONAL POWER CORPORATION</b> AGHAM ROAD, DILIMAN, QUEZON CITY	
PROJECT: SUPPLY, DELIVERY, INSTALLATION AND TEST OF 1026 KL AND 2000 KL POTS FOR PATANUNSIAN OXP, PALASAN OXP, AND JORNALIS OXP INCLUDING CONSTRUCTION OF ASSOCIATED FACILITIES UNDER PACKAGE 1					
LOCATION: PATANUNSIAN, QUEZON					
TITLE: <b>35 CU.M FUEL OIL STORAGE TANK (PLAN &amp; SECTION)</b>					
DESIGNED	BY	CHKD	DATE	SUBMITTED	<i>H. J. MENDOZA</i> Project Engineer A
DRAWN	CHKD			RECOMMENDED	<i>J. J. TORVINA</i> Project Chief
REVIEWED	PRINCIPAL ENGINEER / ARCHT.			APPROVED	<i>G. B. MAGPOC, JR.</i> Manager, EOP
CONSTRUCT					
SUPE.					
MON.					
DWG NO. <b>PatDPP-BDC-17.002</b>			SPEC. NO. <b>LuzP20Z11795-6</b>		
REV.	DATE	NATURE OF REVISION	BY	CHKD	RECD
SCALE AS SHOWN			<b>BID DRAWING</b>		REV. <b>0</b>

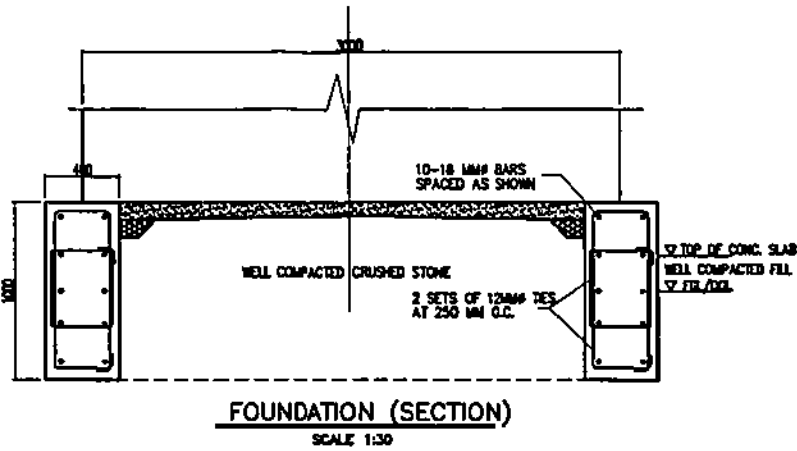
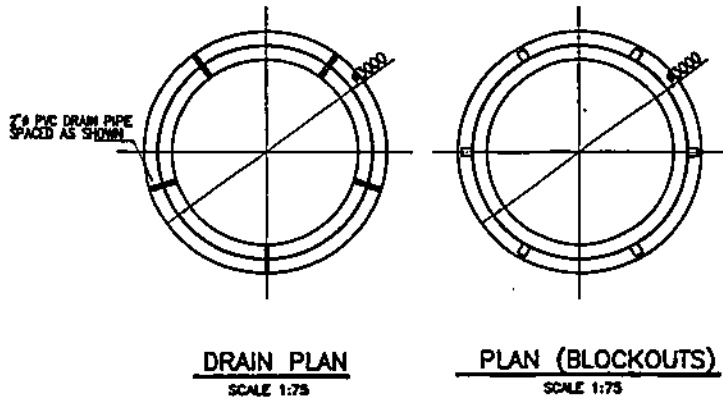

**NOTES:**

1. ALL DIMENSIONS ARE IN MILLIMETERS UNLESS OTHERWISE INDICATED.
2. MINIMUM COMPRESSIVE STRENGTH OF CONCRETE IS  $f_c = 20.7 \text{ MPa}$  (3,000 psi).
3. REINFORCING STEEL BARS SHALL CONFORM TO THE REQUIREMENTS OF THE PHILIPPINE NATIONAL STANDARD (LATEST EDITION) FOR DEFORMED BARS GRADE 275.
4. ASSUMED ALLOWABLE BEARING CAPACITY IS 180 KPa WITHOUT THE PRESENCE OF WATER TABLE.
5. FINAL LAYOUT AND DETAILS OF ANCHOR BOLTS AND TANK SHELL PLATE INCLUDING ALL MECHANICAL AND PIPING SYSTEMS WILL BE REFERRED TO RELEVANT MECHANICAL DRAWINGS.
6. PVC DRAIN PIPES SHALL BE PROVIDED WITH DEPENDABLE SCREENS TO HOLD THE GRAVEL FILTER FROM PASSING THROUGH.
7. ALL ANCHOR BOLT BLOCKOUTS SHALL BE FILLED WITH CEMENT GROUT.
8. WORK THIS DRAWING WITH MECHANICAL DRAWINGS.

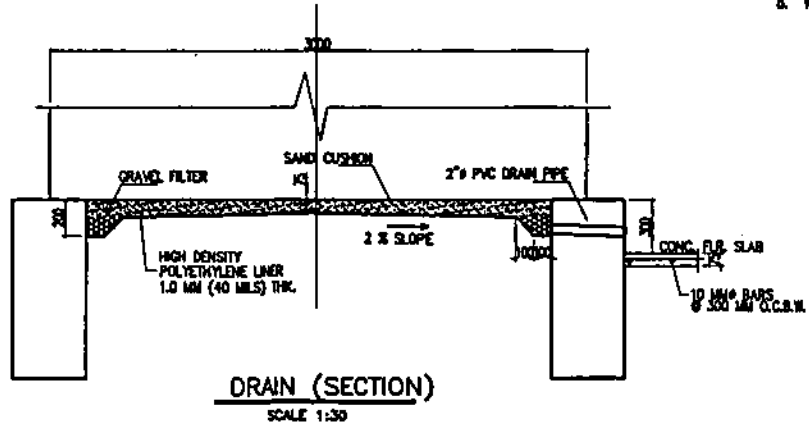
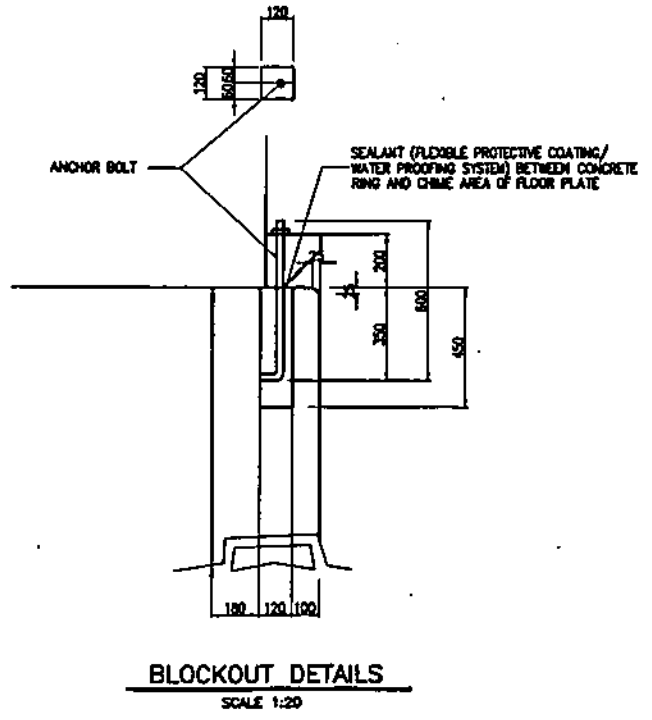

OWNER:		NATIONAL POWER CORPORATION AGHAM ROAD, DILIMAN, QUEZON CITY	
PROJECT: SUPPLY, DELIVERY, INSTALLATION AND TEST OF LICE NO. AND ZERO NO. PUMP FOR PATANUNGGAN DPP, PALANAN DPP, AND JONALIS DPP INCLUDING CONSTRUCTION OF ASSOCIATED FACILITIES UNDER PACKAGE 1			
LOCATION: PATANUNGGAN, QUEZON			
TITLE:		<b>35 CU.M FUEL OIL STORAGE TANK (PLAN &amp; DETAILS)</b>	
DESIGNED	BY	CHKD	DATE
DRAWN	DATE		
REVIEWED	PRINCIPAL ENGR. / ARCHT.		RECOMMENDED
CIVIL/ARCHT			
ELEC			
MECH			
SUBMITTED: <i>H. L. MENDOZA</i>		RECOMMENDED: <i>J. JORVINA</i>	
APPROVED: <i>O. B. MAGPOC, JR.</i>			
DWG. NO. PatDPP-BDC-17.003		SPEC. NO. LuzP20Z1179S	
REV.	DATE	NATURE OF REVISION	BY
SCALE AS SHOWN		<b>BID DRAWING</b>	
		REV 0	

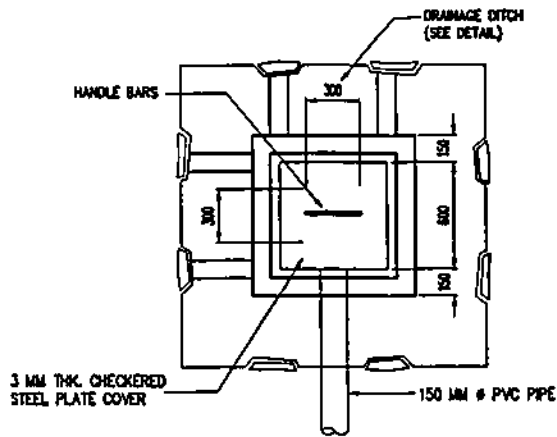

PLAN

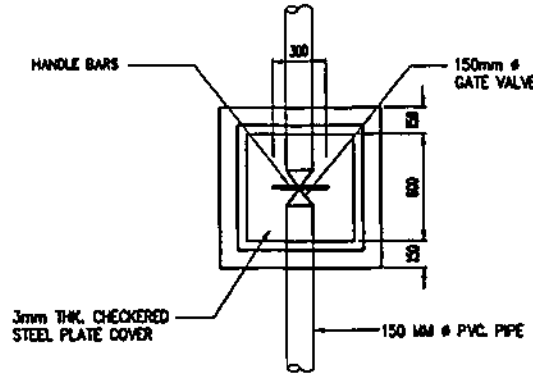

PLAN

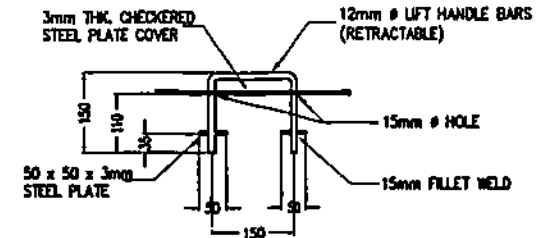

HANDLE BAR DETAIL

SCALE 1:10

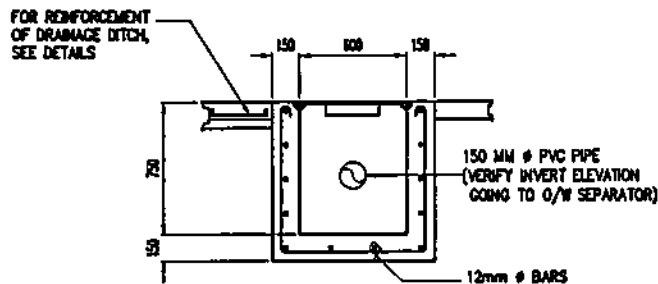

SECTION

DRAIN PIT DETAIL

SCALE 1:30

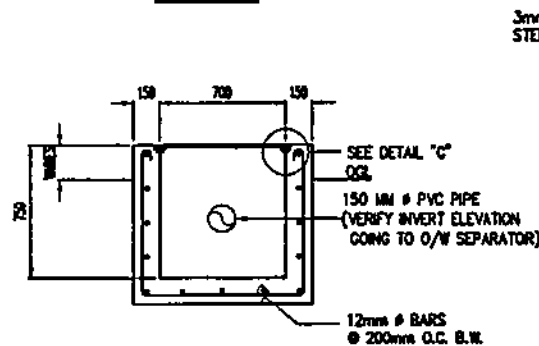

SECTION

VALVE BOX DETAIL

SCALE 1:30

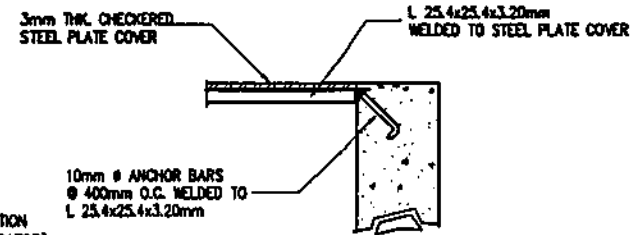

DETAIL - C

SCALE 1:10

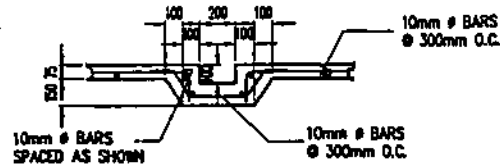

DRAINAGE DITCH DETAIL

SCALE 1:30

OWNER:				NATIONAL POWER CORPORATION AGHAM ROAD, DILIMAN, QUEZON CITY	
PROJECT: SUPPLY, DELIVERY, INSTALLATION AND TEST OF 12KV XL AND 22KV XL POST FOR PATMANANGSAL, DIPP, PALAMANG DIPP, AND JORJALO DIPP INCLUDING CONSTRUCTION OF ASSOCIATED FACILITIES UNDER PACKAGE 1					
LOCATION: PATMANANGSAL, QUEZON					
TITLE: <b>DRAIN PIT, VALVE BOX &amp; DRAINAGE DITCH (PLAN, SECTION &amp; DETAILS)</b>					
DESIGNED	BY	CHKD	DATE	SUBMITTED	H. J. MENDOZA
DRAWN	ENGR				
REVIEWED	PRINCIPAL ENGR./ARCHT.	RECOMMENDED			V. JORJINA
CONTRACT					
BLK.				APPROVED	O. B. MAGPOC, JR.
MECH.					
DWG. NO. PatDPP-BDC-17.004		SPECL. NO. LuzP20Z11795-1			
REV.	DATE	NATURE OF REVISION	BY	CHKD.	REV. APP'D.
SCALE AS SHOWN			BID DRAWING		REV. 0

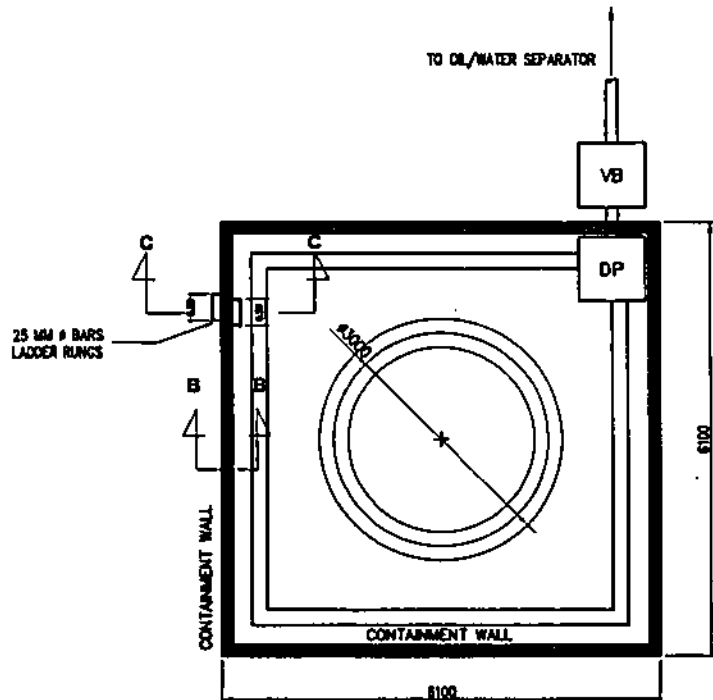

**CONTAINMENT WALL LAYOUT**

SCALE 1:75

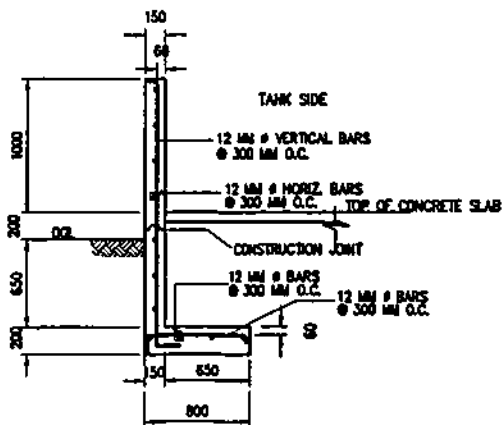

**SECTION B-B**

SCALE 1:40

**CONTAINMENT WALL SECTION**

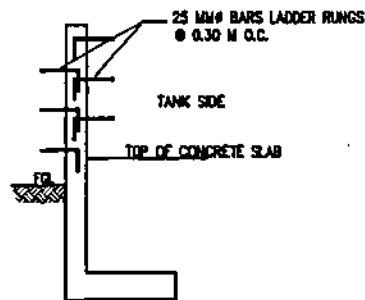

**SECTION C-C**

SCALE 1:40

**LADDER RUNG SECTION**

**NOTES:**

1. ALL DIMENSIONS & ELEVATIONS ARE IN METERS UNLESS OTHERWISE SPECIFIED.
2. MINIMUM COMPRESSIVE STRENGTH OF CONCRETE SHALL BE  $f_c = 20.70 \text{ MPa}$  AT 28 DAYS PERIOD.
3. ALL REINFORCING BARS SHALL CONFORM TO THE LATEST REQUIREMENTS OF PWS FOR DSB GRADE 275.
4. PROVIDE PVC WATERSTOP (6"x1/4" PLAIN DUMBBELL TYPE) AT CONSTRUCTION JOINT.
5. ALL ASPECTS OF CONSTRUCTION AND DETAILING OF REINFORCEMENTS SHALL BE IN ACCORDANCE WITH THE LATEST EDITION OF THE ACI CODE.

OWNER:		 <b>NATIONAL POWER CORPORATION</b> AGHAM ROAD, DILIMAN, QUEZON CITY	
PROJECT: SUPPLY, DELIVERY, INSTALLATION AND TEST OF 1200 KL AND 2000 KL POND FOR PATNAMUNGAN DDP, PALAMAN DDP, AND JOMALIS DDP INCLUDING CONSTRUCTION OF ASSOCIATED FACILITIES UNDER PACKAGE 1			
LOCATION: PATNAMUNGAN, QUEZON			
TITLE: <b>CONTAINMENT WALL AND LADDER RUNG (PLAN, SECTION &amp; DETAILS)</b>			
DESIGNED	BY	CHKD	DATE
DRAWN	DASH		
REVIEWED	PRINCIPAL ENGR. / ARCHT.		RECOMMENDED
CIVIL/ARCHT			
ELEC.			APPROVED:
MECH.			

DWG. NO. PatDPP-BDC-17.005      SPECS. NO. LuzP20Z11795e

REV.	DATE	NATURE OF REVISION	BY	CHKD.	RECD.	APPL.

SCALE: AS SHOWN      **BID DRAWING**      REV. 0

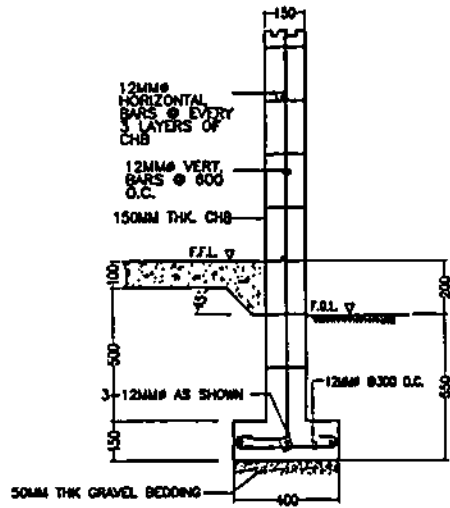

**WALL SECTION**  
SCALE 1:20

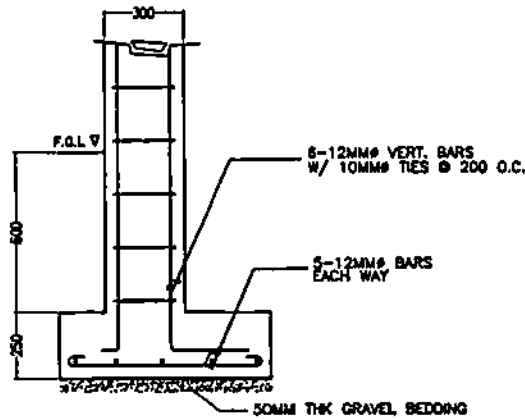

**ELEVATION**  
SCALE 1:20

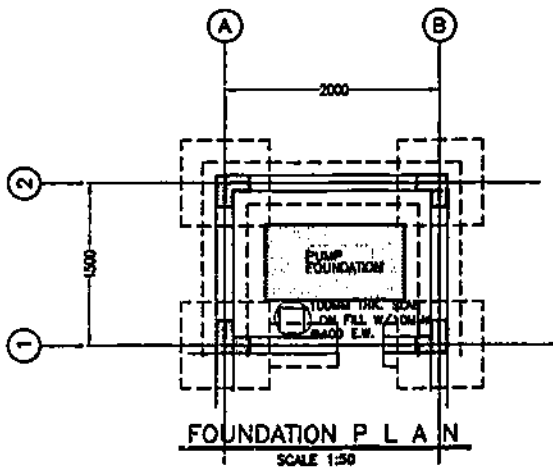

**FOUNDATION PLAN**  
SCALE 1:50

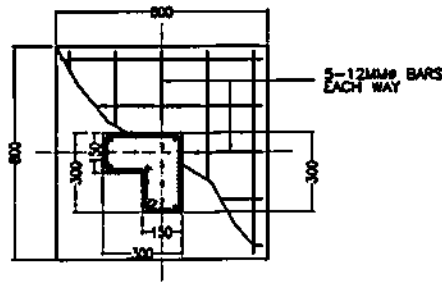

**PLAN**  
**COLUMN FOOTING DETAIL**  
SCALE 1:20

**NOTES:**

1. ALL DIMENSIONS ARE IN MILLIMETERS UNLESS OTHERWISE INDICATED.
2. MINIMUM COMPRESSIVE STRENGTH OF CONCRETE AT 28-DAY PERIOD SHALL BE 20.70 MPa (3000 PSI).
3. REINFORCING STEEL BARS SHALL CONFORM TO THE LATEST REQUIREMENTS OF PNS FOR DEFORMED STEEL BARS GRADE 275.
4. ALL ASPECTS OF CONSTRUCTION AND DETAILING OF REINFORCEMENTS SHALL BE IN ACCORDANCE WITH THE LATEST PROVISIONS OF ACI CODE.
5. DEGREE OF COMPACTION OF BACKFILL SHALL BE 90% OF RELATIVE DENSITY.

OWNER:				<b>NATIONAL POWER CORPORATION</b> AGHAM ROAD, DILIMAN, QUEZON CITY	
PROJECT: SUPPLY, DELIVERY, INSTALLATION AND TEST OF 132Kv AND 230Kv POST FOR PATNARANUNGAN DPP, PALAMAN DPP, AND JOMALIG DPP INCLUDING CONSTRUCTION OF ASSOCIATED FACILITIES UNDER PACKAGE 1					
LOCATOR: VARIOUS AREAS IN QUEZON					
TITLE: <b>PUMPHOUSE</b> (FOUNDATION PLAN, SECTION & DETAILS)					
DESIGNED	BY	CHKD	DATE	SUBMITTED	<i>M. J. MENDOZA</i>
DRAWN	DESIGN			RECOMMENDED	<i>J. JORVINA</i>
REVIEWED	PRINCIPAL ENGR. / ARCHT.			APPROVED	<i>G. B. MAGPOC, JR.</i>
CHALMANT				MANAGER	
ELEC.					
MECH.					
DWA NO. PKG1-BDC-17.001			SPEC. NO. LUZP202117959		
REV. DATE		NATURE OF REVISION		BY	CHKD
SCALE AS SHOWN		<b>EID DRAWING</b>		REV. 0	

**NOTES:**

1. ALL DIMENSIONS ARE IN MILLIMETERS UNLESS OTHERWISE INDICATED.
2. MINIMUM COMPRESSIVE STRENGTH OF CONCRETE AT 28-DAY PERIOD SHALL BE 20.70 MPa (3000 PSI).
3. REINFORCING STEEL BARS SHALL CONFORM TO THE LATEST REQUIREMENTS OF PNS FOR DEFORMED STEEL BARS GRADE 275.
4. ALL ASPECTS OF CONSTRUCTION AND DETAILING OF REINFORCEMENTS SHALL BE IN ACCORDANCE WITH THE LATEST PROVISIONS OF ACI CODE.

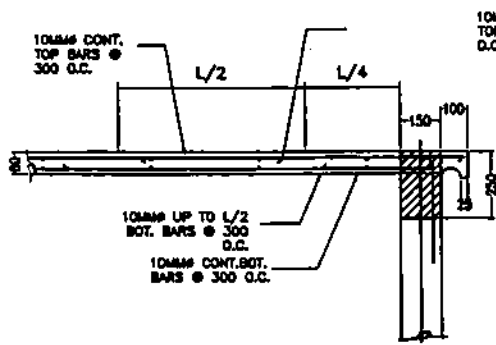

**ROOF SLAB REINFORCEMENT**

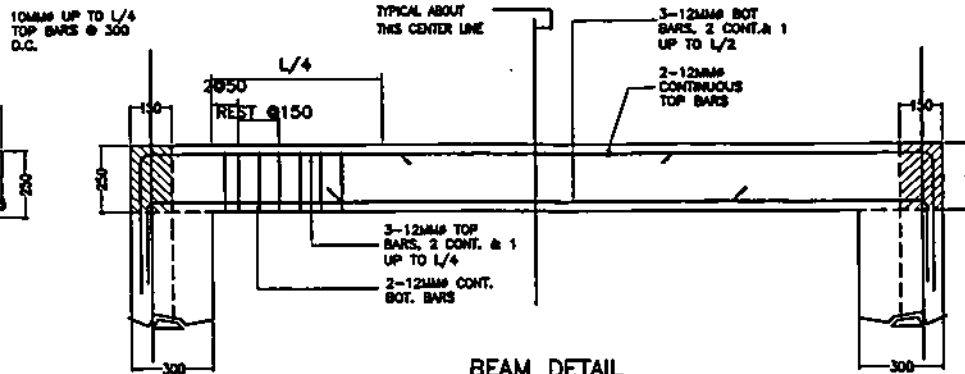

**BEAM DETAIL**

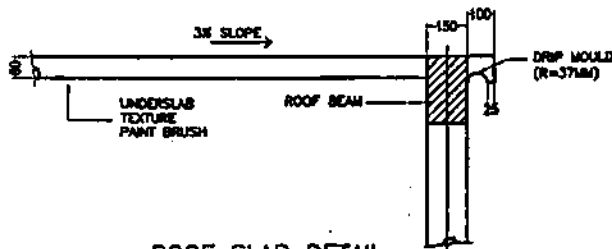

**ROOF SLAB DETAIL**

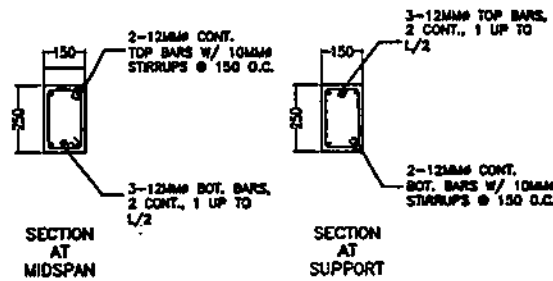

**BEAM SECTION**

OWNER:		 NATIONAL POWER CORPORATION AGHAM ROAD, DILIMAN, QUEZON CITY	
PROJECT: SUPPLY, DELIVERY, INSTALLATION AND TEST OF 125 KL AND 2500 KL FOST FOR PATANUNGAN DFP, PALANAN DFP, AND JOMALLS DFP INCLUDING CONSTRUCTION OF ASSOCIATED FACILITIES UNDER PACKAGE 1			
LOCATION: VARIOUS AREAS IN QUEZON			
TITLE: <b>PUMPHOUSE (ROOF BEAM &amp; ROOF SLAB, SECTION, DETAILS)</b>			
DESIGNED	BY	CHKD	DATE
DRAWN	DATE		
REVIEWED	PRINCIPAL ENGR. / ARCHT.		RECOMMENDED
CYLIANT			
ELC.			
MECA			
DWS. NO. PKG1-BDC-17.002		SPEC. NO. Lu2P202117950	
SCALE: 1:20	BID DRAWING		REV 0

REV.	DATE	NATURE OF REVISION	BY	CHKD	RECD	APPD.





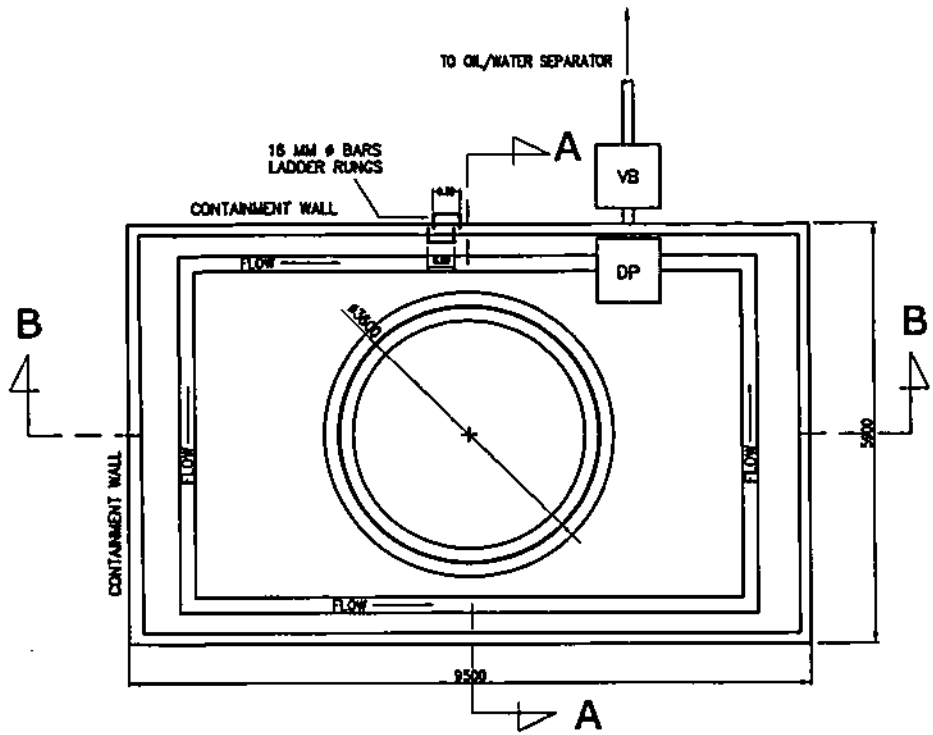

**LEGEND:**

- DP - DRAIN PIT
- VB - VALVE BOX

**NOTES:**

1. ALL DIMENSIONS ARE IN MILLIMETERS UNLESS OTHERWISE INDICATED.
2. WORK THIS WITH MECHANICAL DRAWINGS.

**PLAN**  
SCALE 1:75

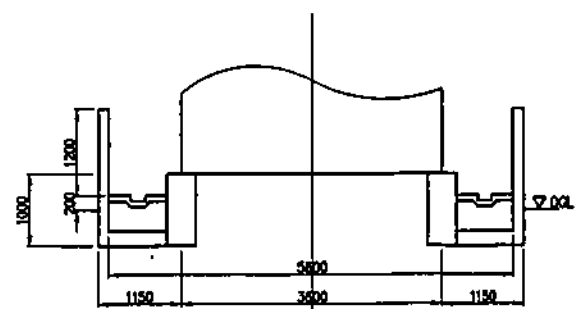

**SECTION THRU A**  
SCALE 1:75

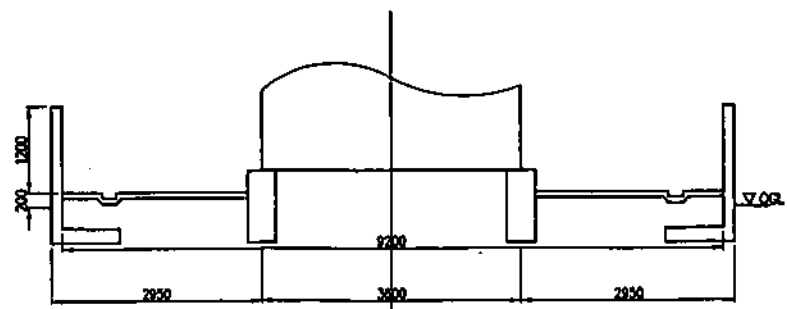

**SECTION THRU B**  
SCALE 1:75

OWNER:				<b>NATIONAL POWER CORPORATION</b> AGHAM ROAD, DILIMAN, QUEZON CITY	
PROJECT: SUPPLY, DELIVERY, INSTALLATION AND TEST OF 1206 KG AND 2206 KG POTS FOR PATANUNGGAN DPP, PALANAN DPP, AND JOMALIS DPP INCLUDING CONSTRUCTION OF ASSOCIATED FACILITIES UNDER PACKAGE 1					
LOCATION: PALANAN, ISABELA					
TITLE: <b>60 CU.M. FUEL OIL STORAGE TANK (PLAN &amp; SECTION)</b>					
DESIGNED	BY	CHKD	DATE	SUBMITTED	<i>H. L. KENDOZA</i>
DRAWN	DATE			RECOMMENDED	<i>J. TORVINA</i>
REVIEWED	PRINCIPAL ENGR. / ARCHT.			APPROVED	<i>G. B. MAGPOC, JR.</i>
CHLDRONT					
ELEC.					
MECH.					
DWG. NO. PdDPP-BDC-17.002		SPEC. NO. LuzP20Z1179S*			
SCALE: AS SHOWN		<b>BID DRAWING</b>		REV. 0	

REV.	DATE	NATURE OF REVISION	BY	CHKD.	RECD.	APPR.

**NOTES:**

1. ALL DIMENSIONS ARE IN MILLIMETERS UNLESS OTHERWISE INDICATED.
2. MINIMUM COMPRESSIVE STRENGTH OF CONCRETE IS  $f_c = 20.7 \text{ MPa}$  (3,000 psi).
3. REINFORCING STEEL BARS SHALL CONFORM TO THE REQUIREMENTS OF THE PHILIPPINE NATIONAL STANDARD (LATEST EDITION) FOR DEFORMED BARS GRADE 275.
4. ASSUMED ALLOWABLE BEARING CAPACITY IS 180 KPa WITHOUT THE PRESENCE OF WATER TABLE.
5. FINAL LAYOUT AND DETAILS OF ANCHOR BOLTS AND TANK SHELL PLATE INCLUDING ALL MECHANICAL AND PIPING SYSTEMS WILL BE REFERRED TO RELEVANT MECHANICAL DRAWINGS.
6. PVC DRAIN PIPES SHALL BE PROVIDED WITH DEPENDABLE SCREENS TO HOLD THE GRAVEL FILTER FROM PASSING THROUGH.
7. ALL ANCHOR BOLT BLOCKOUTS SHALL BE FILLED WITH CEMENT GROUT.
8. WORK THIS DRAWING WITH MECHANICAL DRAWINGS.

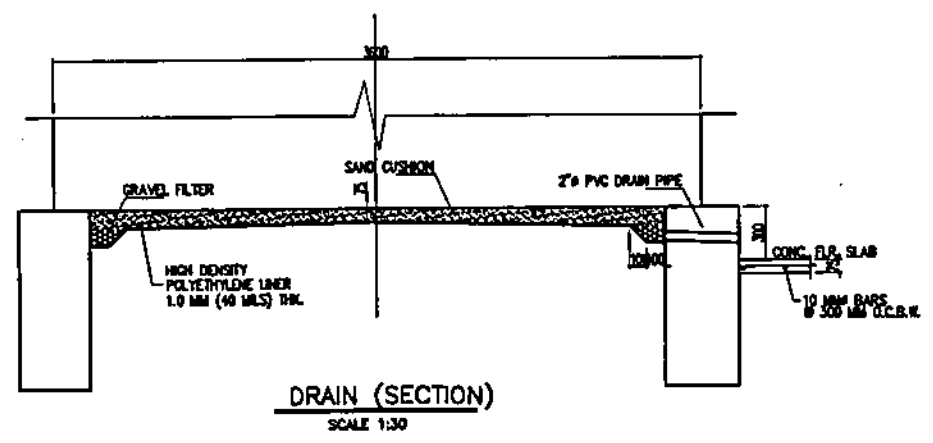
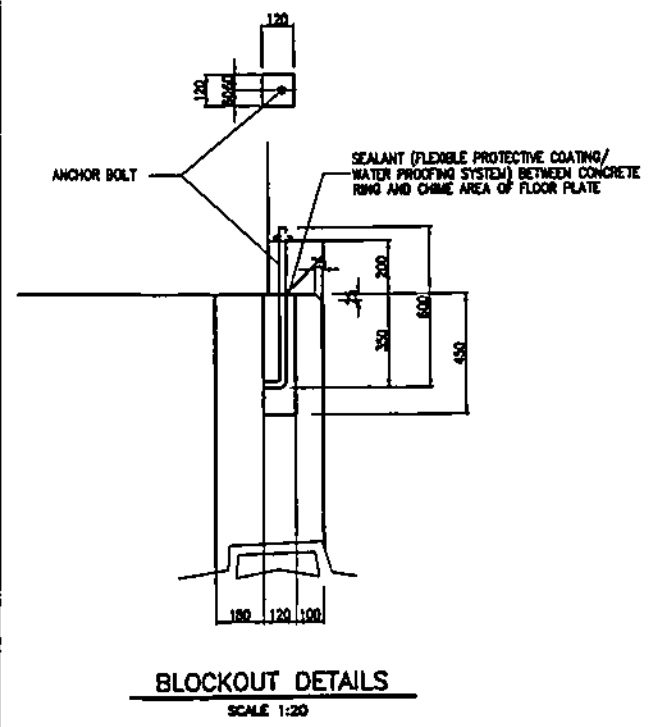
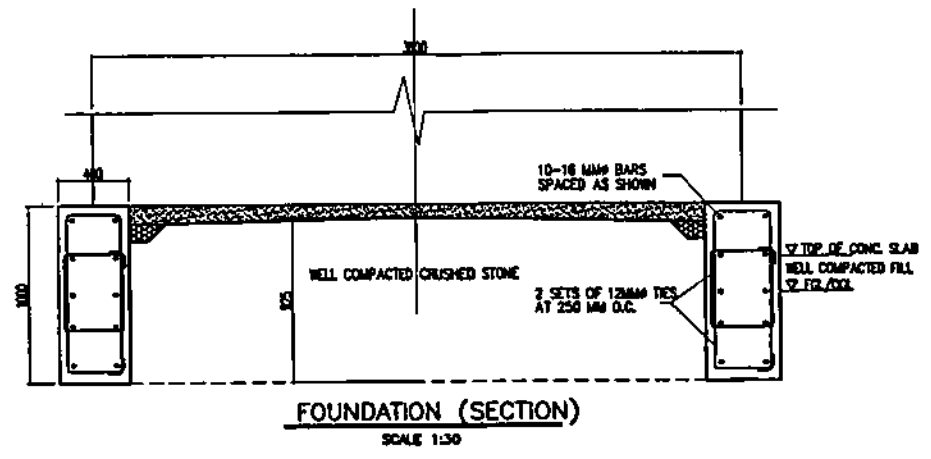
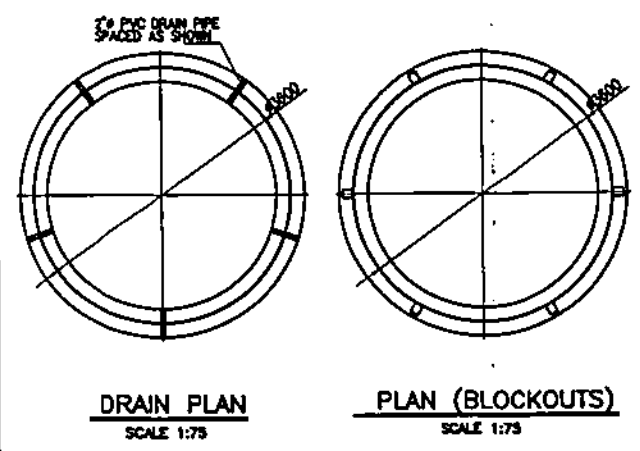

OWNER:		<b>NATIONAL POWER CORPORATION</b> AGHAM ROAD, DILIMAN, QUEZON CITY	
PROJECT: SUPPLY, DELIVERY, INSTALLATION AND TEST OF 1500 KL AND 2200 KL POTS FOR FATAKUNINGAN GPP, PALANAN DFP, AND JOMALAI DFP INCLUDING CONSTRUCTION OF ASSOCIATED FACILITIES UNDER PACKAGE 1			
LOCATION: PALANAN, MARBLA			
TITLE: <b>60 CU.M. FUEL OIL STORAGE TANK (PLAN &amp; DETAILS)</b>			
DESIGNED	BY	CHKD	DATE
DRAWN	DMN		
REVIEWED	PRINCIPAL ENGR./ARCHT.		RECOMMENDED
CHARLANT			FORVINA
ELEC.			
MECH.			APPROVED
			G. B. BAGONG JR.
DWG. NO. PalDPP-BDC-17.003		SPEC. NO. LuzP20Z1179S0	
SCALE AS SHOWN		BID DRAWING	
REV.	DATE	NATURE OF REVISION	BY
			CHKD
			RECD.
			APP.
			REV. 0

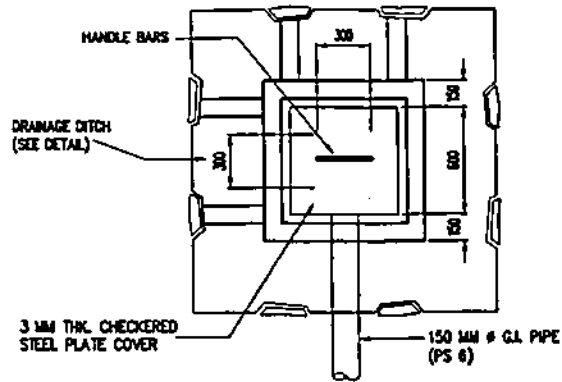

PLAN

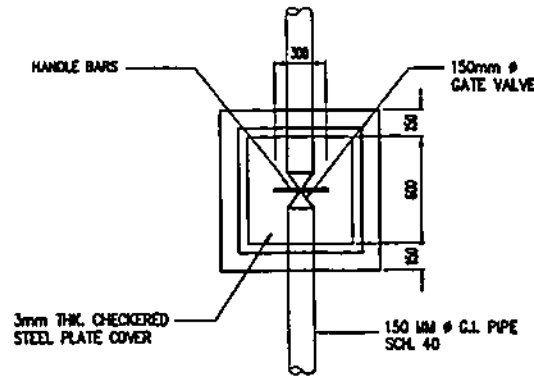

PLAN

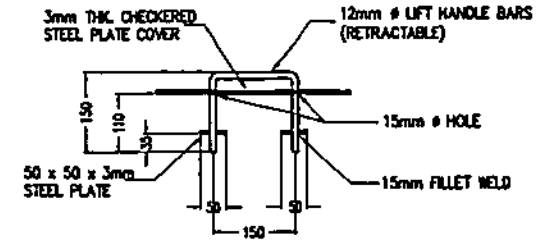

SCALE 1:10

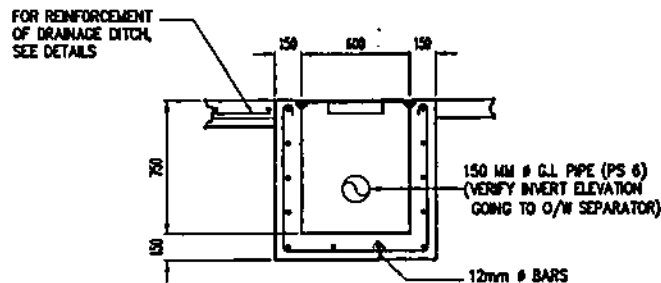

DRAIN PIT DETAIL

SCALE 1:30

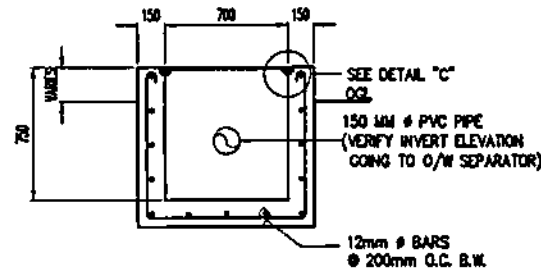

VALVE BOX DETAIL

SCALE 1:30

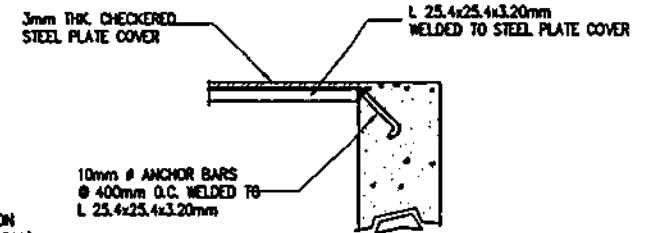

SCALE 1:10

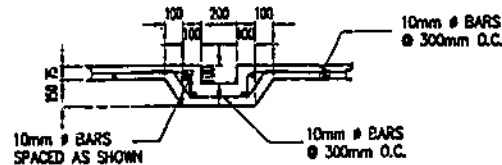

SCALE 1:30

OWNER:		NATIONAL POWER CORPORATION AGHAM ROAD, DR. IMAN, QUEZON CITY	
PROJECT: SUPPLY, DELIVERY, INSTALLATION AND TEST OF 1238 KL AND 2028 KL PUMP FOR PATNANGKAY DDP, PALAMAR DDP, AND JONALAS DDP INCLUDING CONSTRUCTION OF ASSOCIATED FACILITIES UNDER PACKAGE 1			
LOCATION: PALAMAR, BAMBALA			
TITLE: DRAIN PIT, VALVE BOX & DRAINAGE DITCH (PLAN, SECTION & DETAILS)			
DESIGNED	BY	CHKD	DATE
DRAWN	DJMM		
REVIEWED	PRINCIPAL ENGR./ARCHT.	RECOMMENDED	
CIVIL/ARCHT			
ELEC.			
MECH.			
APPROVED:		G. B. BAGPOC, JR. Engrg. III	
DWG. NO. PdDPP-BDC-17.004		SPEC. NO. Lu2P20Z1179S	
REV.	DATE	NATURE OF REVISION	BY
SCALE AS SHOWN			BID DRAWING
			REV. 0

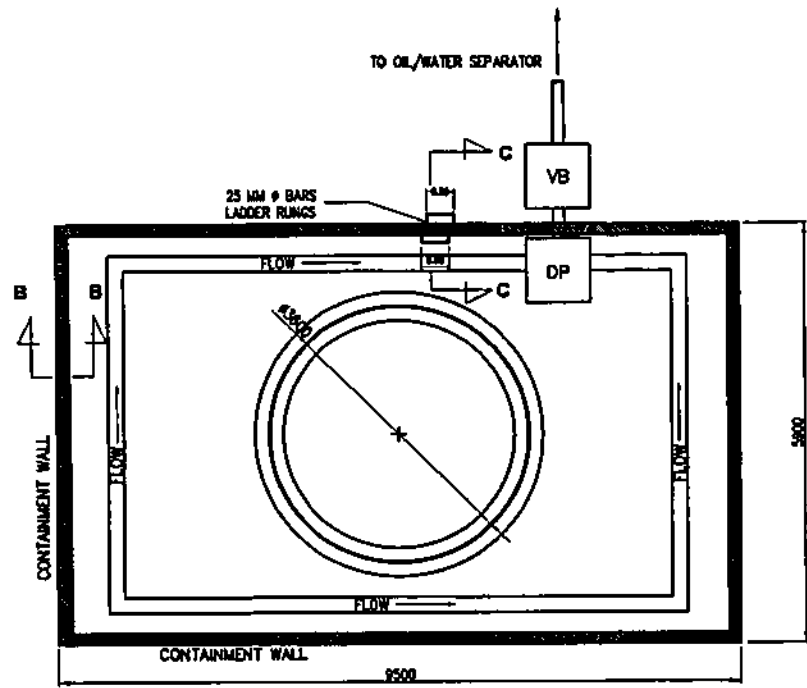

**CONTAINMENT WALL LAYOUT**

SCALE 1:75

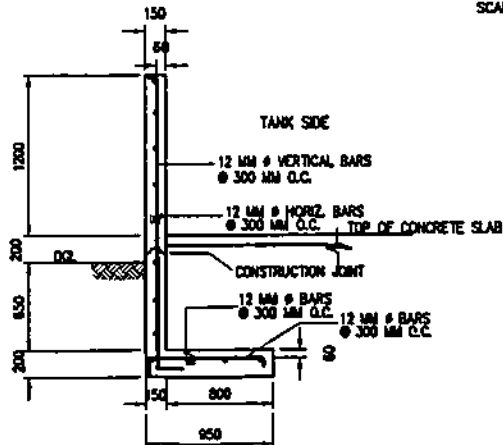

**SECTION B-B**

SCALE 1:40

**CONTAINMENT WALL SECTION**

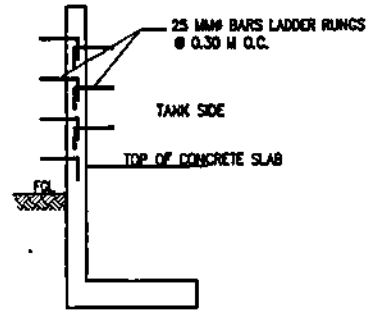

**SECTION C-C**

SCALE 1:40

**LADDER RUNG SECTION**

**NOTES:**

1. ALL DIMENSIONS & ELEVATIONS ARE IN METERS UNLESS OTHERWISE SPECIFIED.
2. MINIMUM COMPRESSIVE STRENGTH OF CONCRETE SHALL BE  $f_c = 20.70 \text{ MPa}$  AT 28 DAYS PERIOD.
3. ALL REINFORCING BARS SHALL CONFORM TO THE LATEST REQUIREMENTS OF PHS FOR DSB GRADE 275.
4. PROVIDE PVC WATERSTOP (6"x16" PLAN DUMBELL TYPE) AT CONSTRUCTION JOINT.
5. ALL ASPECTS OF CONSTRUCTION AND DETAILING OF REINFORCEMENTS SHALL BE IN ACCORDANCE WITH THE LATEST EDITION OF THE ACI CODE.

<b>NATIONAL POWER CORPORATION</b> AGHAM ROAD, DILIMAN, QUEZON CITY				
PROJECT: SUPPLY, DELIVERY, INSTALLATION AND TEST OF 1326 KL AND 2208 KL PORT FOR PATAYANGAN DPP, PALAMAN DPP, AND JOMALIS DPP INCLUDING CONSTRUCTION OF ASSOCIATED FACILITIES UNDER PACKAGE 1				
LOCATION: PALAMAN, MARABELA				
<b>TITLE: CONTAINMENT WALL AND LADDER RUNG</b> <b>(PLAN, SECTION &amp; DETAILS)</b>				
DESIGNED	BY	CHKD	DATE	SUBMITTED
DRAWN	OMM			H. J. MENDOZA Principal Engineer A
REVIEWED	PRINCIPAL ENGR./ARCHT.			J. J. JORVINA Principal Eng.
CIVIL/ARCHT				
ELEC				
MECH				
APPROVED: G. B. MAGPOC, JR. Manager, DDO				
DWG. NO. PdDPP-BDC-17.005		SPECS. NO. LuzP20Z11795b		
SCALE AS SHOWN		<b>BID DRAWING</b>		
REV. 0				

REV.	DATE	NATURE OF REVISION	BY	CHKD.	RECD.	APPR.

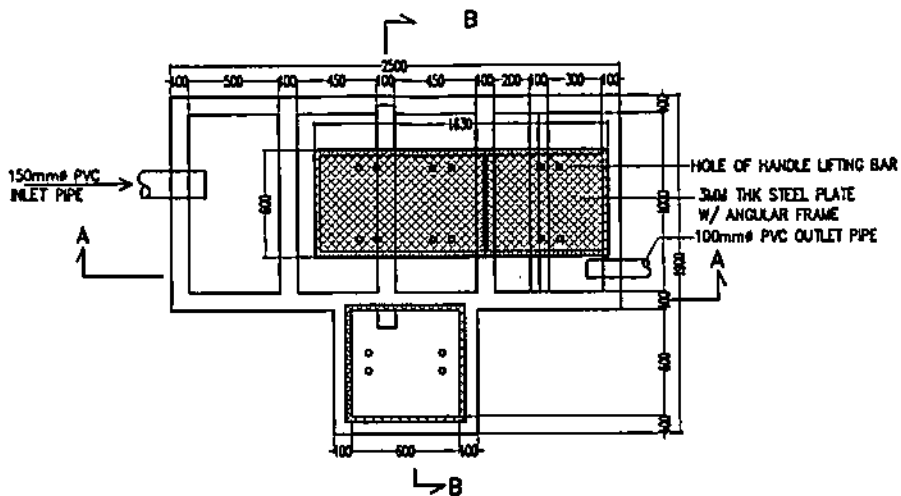

**PLAN**  
SCALE 1:30

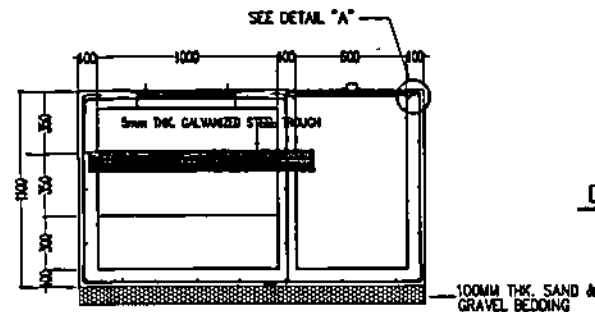

**SECTION B-B**  
SCALE 1:30

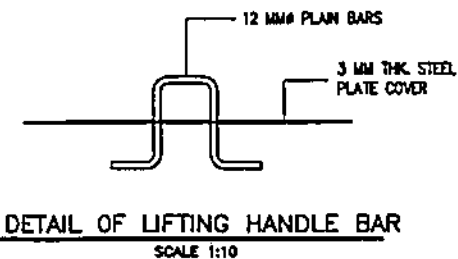

**DETAIL OF LIFTING HANDLE BAR**  
SCALE 1:10

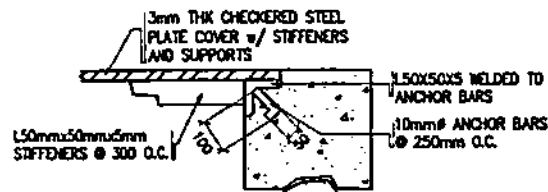

**DETAIL "A"**  
NOT TO SCALE

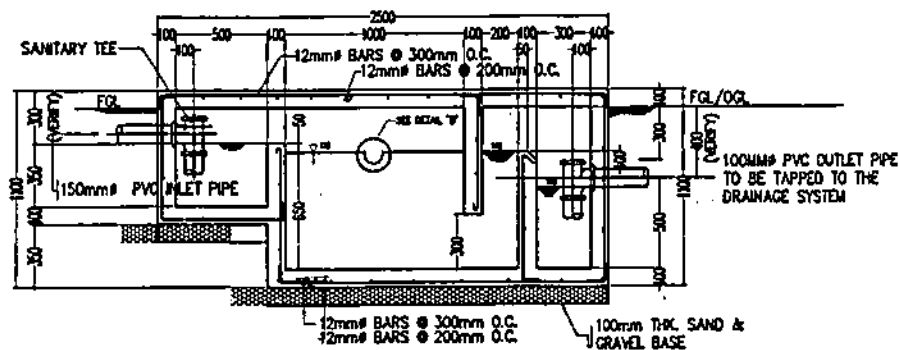

**SECTION A-A**  
SCALE 1:30

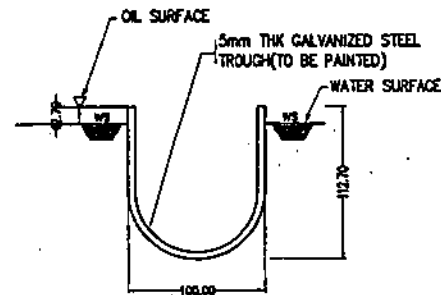



**DETAIL "B"**  
SCALE 1:4

**NOTES:**

1. ALL DIMENSIONS AND ELEVATIONS ARE IN MILLIMETERS UNLESS OTHERWISE INDICATED.
2. MINIMUM COMPRESSIVE STRENGTH OF CONCRETE SHALL BE  $f_c = 20.70$  MPa AT 28 DAY PERIOD.
3. ALL REINFORCING STEEL BARS SHALL CONFORM TO THE LATEST REQUIREMENTS OF PNS FOR DEFORMED STEEL BARS, GRADE 275.
4. ALL ASPECTS OF CONSTRUCTION AND DETAILING OF REINFORCEMENTS SHALL BE IN ACCORDANCE WITH THE PROVISIONS OF ACI CODE.
5. BEFORE THE START OF THE CONSTRUCTION VERIFY THE DRAINAGE STRUCTURES & ELEVATIONS CONNECTED TO THE OIL-WATER SEPARATOR.
6. AFTER THE COMPLETION OF THE CONSTRUCTION, THE OIL-WATER SEPARATOR MUST BE FILLED WITH WATER UP TO THE BOTTOM RIM OF THE STEEL TROUGH.

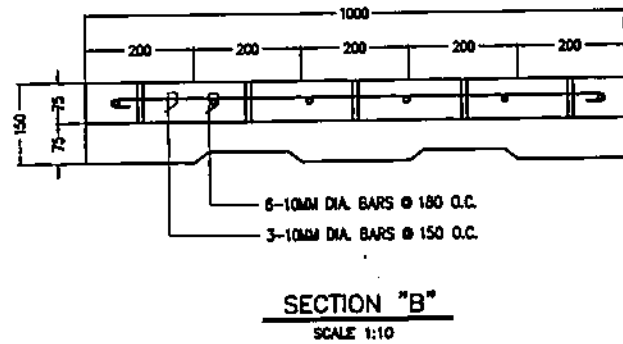
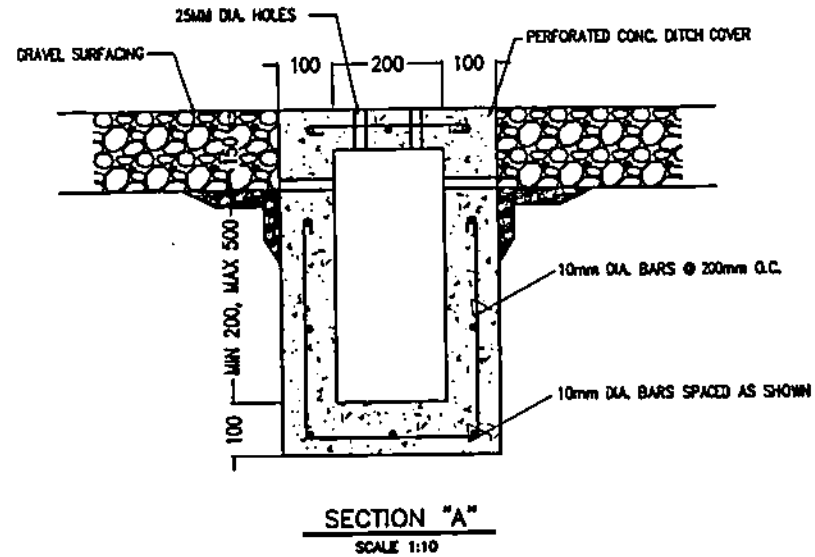
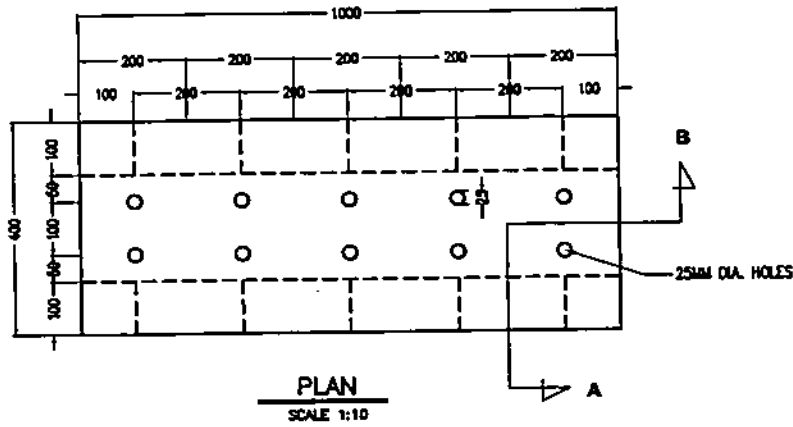
OWNER		 <b>NATIONAL POWER CORPORATION</b> AGHAM ROAD, DILIMAN, QUEZON CITY	
PROJECT: SUPPLY, DELIVERY, INSTALLATION AND TEST OF 1X28 KL AND 2X18 KL PDS FOR PATANGKALAN DIPP, PALANAN DIPP, AND JOMBAL DIPP INCLUDING CONSTRUCTION OF ASSOCIATED FACILITIES UNDER PACKAGE 1			
LOCATION: PALANAN, MARBELA			
TITLE: <b>OIL WATER SEPARATOR (PLAN, SECTIONS &amp; DETAILS)</b>			
DESIGNED	BY	CHKD	DATE
DRAWN	DATE		
REVIEWED	PRINCIPAL ENGR. / ARCHT.	RECOMMENDED	
CHECKED		APPROVED	
ELC.			
MECH.			
DWG. NO. PdDPP-BDC-17.006		SPEC. NO. LUZP202.1179S	
SCALE AS SHOWN		BID DRAWING	
REV.	DATE	NATURE OF REVISION	BY



OWNER:		 <b>NATIONAL POWER CORPORATION</b> AGHAM ROAD, DILIMAN, QUEZON CITY	
PROJECT: SUPPLY, DELIVERY, INSTALLATION AND TEST OF 1X25 KL AND 2200 KL POST FOR PATALINGURAN DPP, PALAMAN DPP, AND JOMALIG DPP INCLUDING CONSTRUCTION OF ASSOCIATED FACILITIES UNDER PACKAGE 1 LOCATION: PALAMAN, MARILIA			
TITLE: <b>DRAINAGE APPURTENANCES</b> (DITCH PLAN & SECTION)			
DESIGNED	BY	CHKD	DATE
DRAWN	DNM		
REVIEWED	PRINCIPAL ENGR./ARCHT.		RECOMMENDED
CIVIL/ARCHT			
ELEC.			APPROVED
MECH.			
DWA. NO. P&IDPP-BDC-17.007		SPECS. NO. LuzP20Z11795e	
SCALE: AS SHOWN		<b>BID DRAWING</b> REV. 0	

REV.	DATE	NATURE OF REVISION	BY	CHKD	RECD	APPR.

**SECTION IX - BID DRAWINGS****MW - MECHANICAL DRAWINGS**



<b>DRAWING NO.</b>	<b>TITLE</b>
PatDPP-BDM-17.001	Equipment/Plant Layout (Patnanungan DPP)
PatDPP-BDM-17.002	Fuel Oil Storage and Piping Layout (Patnanungan DPP)
PatDPP-BDM-17.003	Fuel Oil Storage and Transfer System (P&I Diagram – Patnanungan DPP)
PatDPP-BDM-17.004	Fuel Pump House and Piping Layout (Patnanungan DPP)
PatDPP-BDM-17.005	Plan and Section (Patnanungan DPP)
PaIDPP-BDM-17.001	Existing Equipment/Plant Layout (Palanan DPP)
PaIDPP-BDM-17.002	Proposed Equipment/Plant Layout (Palanan DPP)
PaIDPP-BDM-17.003	Fuel Oil Storage and Piping Layout (Palanan DPP)
PaIDPP-BDM-17.004	Fuel Oil Storage and Transfer System (P&I Diagram – Palanan DPP)
PaIDPP-BDM-17.005	Fuel Pump House and Piping Layout (Palanan DPP)
PaIDPP-BDM-17.006	Plan and Section (Palanan DPP)
JomDPP-BDM-17.001	Equipment/Plant Layout (Jomalig DPP)
JomDPP-BDM-17.002	Fuel Oil Storage and Piping Layout (Jomalig DPP)
JomDPP-BDM-17.003	Fuel Oil Storage and Transfer System (P&I Diagram – Jomalig DPP)
JomDPP-BDM-17.004	Fuel Pump House and Piping Layout (Jomalig DPP)
JomDPP-BDM-17.005	Plan and Section (Jomalig DPP)
PKG135-BDM-17.001	Plate Arrangement and Details (35 KL FOST)
PKG135-BDM-17.002	Nozzle Arrangement and Other Details (35 KL FOST)
PKG135-BDM-17.003	Holding Down Bolt Details (35 KL FOST)
PKG135-BDM-17.004	Level Gauge Indicator Details (35 KL FOST)

<b>DRAWING NO.</b>	<b>TITLE</b>
PKG135-BDM-17.005	Tank, Stair and Railing Details (35 KL FOST)
PKG135-BDM-17.006	Nozzle Details (35 KL FOST)
PKG135-BDM-17.007	Tank Nozzle and Pipings (35 KL FOST)
PKG135-BDM-17.008	Roof and Shell Manhole Details (35 KL FOST)
PKG135-BDM-17.009	Rafter Details (35 KL FOST)
PKG160-BDM-17.001	Plate Arrangement and Details (60 KL FOST)
PKG160-BDM-17.002	Orientation and Details (60 KL FOST)
PKG160-BDM-17.003	Nozzle Details (60 KL FOST)
PKG160-BDM-17.004	Nozzle Arrangement and Other Details (60 KL FOST)
PKG160-BDM-17.005	Tank Nozzles and Pipe (60 KL FOST)
PKG160-BDM-17.006	Roof and Shell Manhole Details (60 KL FOST)
PKG160-BDM-17.007	Level Gauge Indicator Details (60 KL FOST)
PKG160-BDM-17.008	Rafter Details (60 KL FOST)

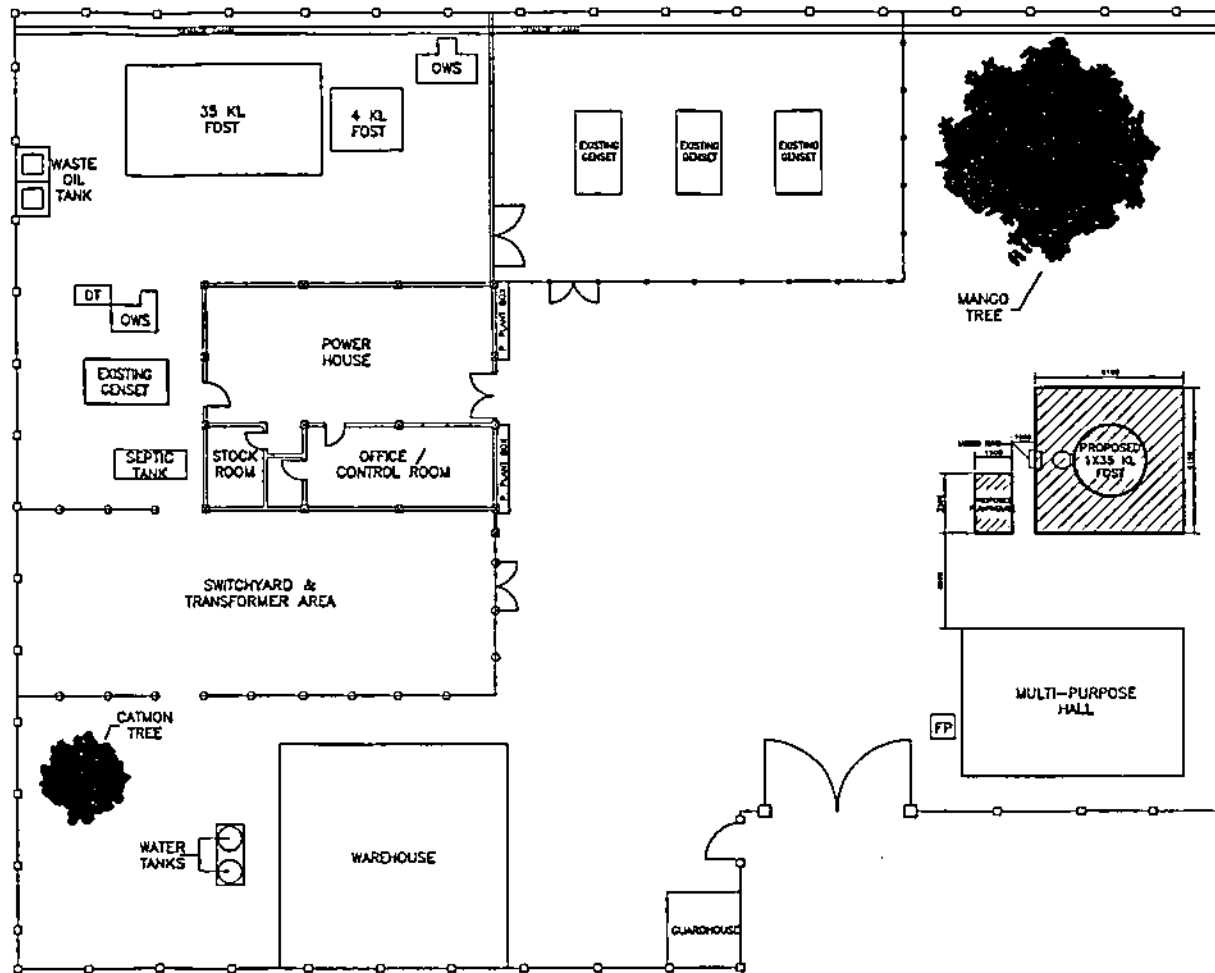



**LEGEND:**

-  - PROPOSED EQUIPMENT/FACILITY
-  - EXISTING EQUIPMENT/FACILITY
- DT - DAY TANK
- OWS - OIL-WATER SEPARATOR
- FOST - FUEL OIL STORAGE TANK

**NOTES:**

1. THIS DRAWING IS FOR REFERENCE PURPOSES ONLY.
2. ALL DIMENSIONS ARE IN MILLIMETERS UNLESS OTHERWISE SPECIFIED.
3. THE CONTRACTOR SHALL SUBMIT DESIGN CALCULATIONS AND FOUNDATION DETAILS FOR ALL EQUIPMENT TO BE SUPPLIED UNDER THIS SCOPE FOR APPROVAL OF NPC E.G. FUEL OIL TRANSFER PUMP.
4. THE DIMENSION SHOWN MAY BE ADJUSTED BASED ON THE ACTUAL DIMENSION OF THE EQUIPMENT TO BE SUPPLIED BY THE CONTRACTOR.
5. WORK THIS DRAWING WITH APPLICABLE CIVIL AND ELECTRICAL DRAWINGS.

OWNER		 <b>NATIONAL POWER CORPORATION</b> ACHAM ROAD, DILIMAN, QUEZON CITY	
PROJECT: SUPPLY, DELIVERY, INSTALLATION AND TEST OF 1X35 KL AND 2X4 KL FOST FOR PATANUNGAN DPP, PALANAN DPP, AND JOMALIG DPP INCLUDING CONSTRUCTION OF ASSOCIATED FACILITIES UNDER PACKAGE 1			
LOCATION: PATANUNGAN, QUEZON			
TITLE:		<b>EQUIPMENT/PLANT LAYOUT</b> 1 X 35 KL FOST PATANUNGAN DPP	
DESIGNED	BY	OWS	DATE
DRAWN	MM		
REVIEWED	PRINCIPAL ENGINEER/ARCHT.	RECOMMENDED	
DATE		DATE	
BY		DATE	
DRAWN: PacDPP-EOM-17-001		DATE: LuzP202117001	
DATE: 1-225		DIP SCANNING	

PROJECT: SUPPLY, DELIVERY, INSTALLATION AND TEST OF 1433 KL AND 354 KL FOST FOR PATANUNGGAN DPP, AND LOMALOG DPP INCLUDING CONSTRUCTION OF ASSOCIATED FACILITIES UNDER PACKAGE 1	
LOCATION: LOMALOG, QUEZON	
TITLE: FUEL, OIL STORAGE AND PIPING LAYOUT 1 X 35 KL FOST PATANUNGGAN DPP	
OWNER:	NATIONAL POWER CORPORATION AGHAM ROAD, DILIMAN, QUEZON CITY
DESIGNED BY:	ENR. J. S. SERRANO
CHECKED BY:	ENR. J. S. SERRANO
APPROVED BY:	C. B. MACKAY JR.
DATE:	NOV. 1988
SCALE:	AS SHOWN
NO.:	1
REV.:	
DATE:	
DESCRIPTION:	
NO.:	
REV.:	
DATE:	
DESCRIPTION:	
NO.:	
REV.:	
DATE:	
DESCRIPTION:	

NOTES:

1. THIS DRAWING IS FOR REFERENCE PURPOSES ONLY.
2. ALL DIMENSIONS ARE IN MILLIMETERS UNLESS OTHERWISE SPECIFIED.
3. ALL EQUIPMENT SHOWN IN THIS DRAWING SHALL BE SUPPLIED, CONSTRUCTED, TESTED AND COMMISSIONED BY THE CONTRACTOR.
4. EQUIPMENT AND PIPING ARRANGEMENT MAY BE ADJUSTED TO SUIT ACTUAL SITE CONDITIONS.
5. REFER TO CIVIL DRAWINGS FOR THE DETAILS OF CIVIL STRUCTURES/FACILITIES INCLUDING EQUIPMENT FOUNDATION AND TRENCH.
6. FUEL PIPE SHALL BE GENERALLY INSTALLED ABOVEGROUND, WHERE INSTALLATION IS REQUIRED UNDERGROUND. MINIMUM DEPTH OF EMBEDDED PIPES SHALL BE NOT LESS THAN 300 MM IN OPEN GROUNDS AND 400 MM UNDER ROADWAYS. FOR PIPES THAT CROSS ROADWAY, PIPE SLEEVE OF STEEL MATERIALS OR RSC SHALL BE PROVIDED. REFER ALSO TO TYPICAL PIPE SUPPORTS DRAWINGS FOR REFERENCE.
7. LOCAL PANEL SHALL BE PROVIDED EACH AT THE FUEL PUMPHOUSE AND IN THE POWERHOUSE (SEE ELECTRICAL DRAWINGS). EACH LOCAL PANEL SHALL BE PROVIDED WITH START AND STOP PUSH BUTTONS WITH RESPECTIVE STATUS INDICATING LIGHTS. LOCAL PANEL AT THE PUMPHOUSE SHALL BE PROVIDED WITH LOCAL/REMOTE SELECTOR SWITCH.

- LEGEND:
- ▨ - EXISTING EQUIPMENT/FACILITY
  - - PROPOSED EQUIPMENT/FACILITY
  - ⊗ - BUTTERFLY VALVE W/ BOX
  - ⊘ - GATE VALVE
  - ⊗ - GATE VALVE (NORMALLY CLOSED)
  - ▽ - REDUCER
  - WM - FLEXIBLE HOSE
  - DT - DAY TANK
  - OWS - OIL-WATER SEPARATOR
  - FOST - FUEL OIL STORAGE TANK

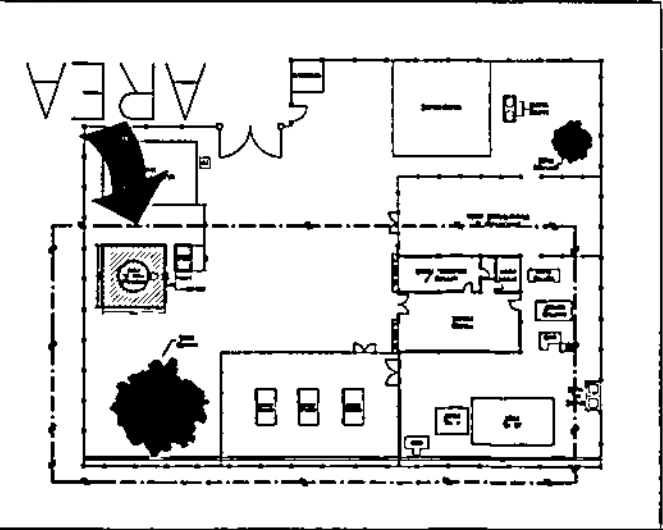
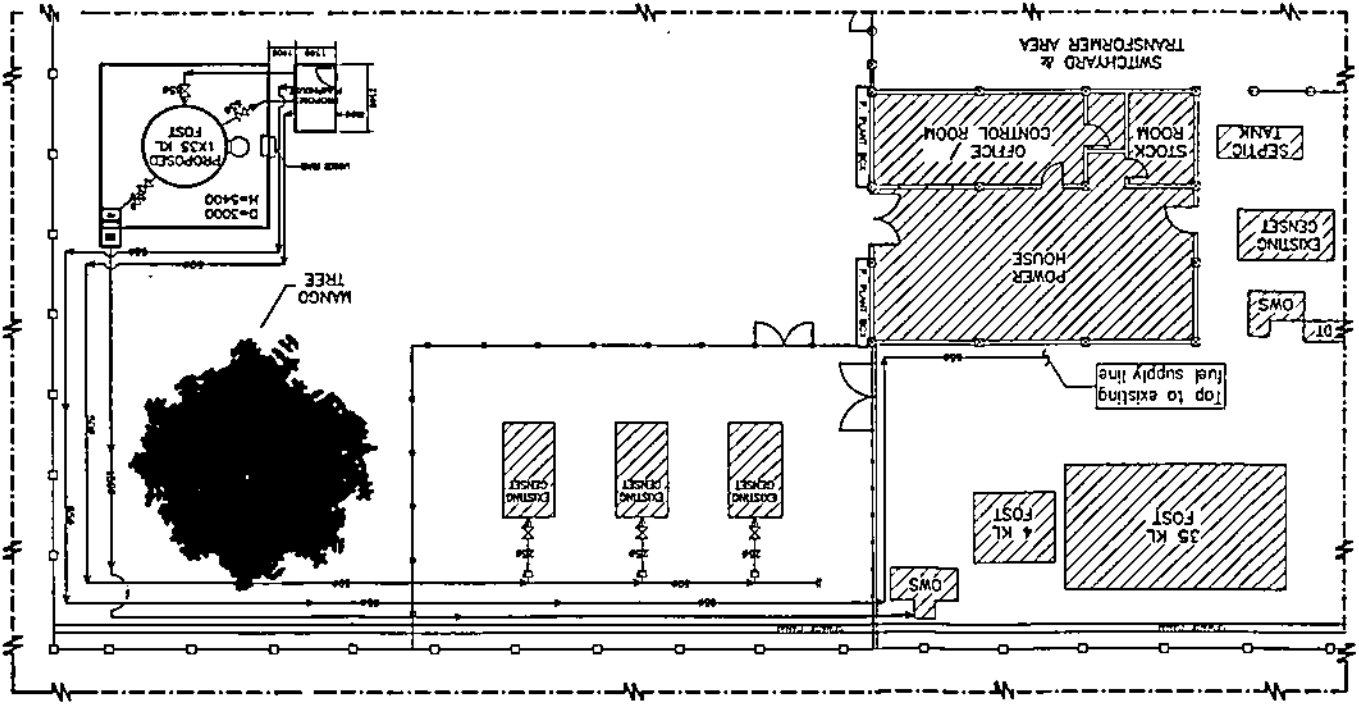

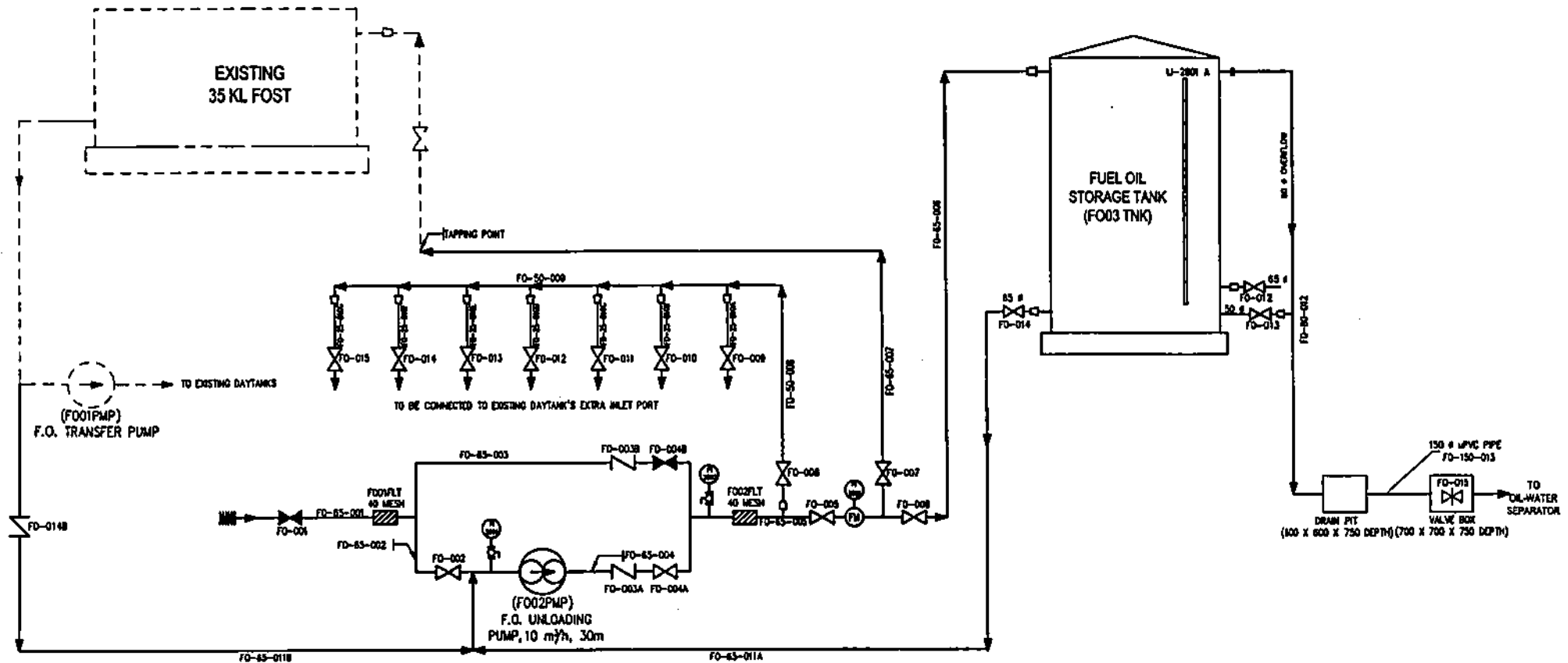

**LEGEND:**

- GLOBE VALVE
- GLOBE VALVE (NORMALLY CLOSED)
- BUTTERFLY VALVE W/ BOX
- GATE VALVE
- GATE VALVE (NORMALLY CLOSED)
- CHECK VALVE
- EXISTING EQUIPMENT/FACILITIES
- FUEL FILTER
- REDUCER
- PRESSURE GAUGE
- FLOW INDICATOR
- FLOW METER
- FLEXIBLE HOSE

**NOTES:**

1. ALL DIMENSIONS ARE IN MILLIMETERS UNLESS OTHERWISE SPECIFIED.
2. ALL PIPING, PIPE SUPPORTS AND FITTINGS, VALVES AND ACCESSORIES SHALL BE SUPPLIED, INSTALLED AND TESTED BY THE CONTRACTOR. PIPES ARE GENERALLY INSTALLED ABOVE GROUND UNLESS OTHERWISE SHOWN ON THE DRAWING. PIPES TO BE INSTALLED UNDERGROUND SHALL BE NOT LESS THAN 300 MM DEPTHA.
3. FUEL OIL PIPES SHALL CONFORM TO ASTM A53 GR. B, SEAMLESS PIPE AND SCHEDULE 40. MATERIALS FOR VALVES 65MM AND ABOVE SHALL BE CAST IRON AND CAST BRONZE FOR 50 MM & BELOW.
4. REFER TO CIVIL DRAWINGS FOR THE DETAILED DRAWINGS OF TANK FOUNDATION/CONTAINMENT WALL, DRAIN PIT AND VALVE BOX.
5. VALVE INSIDE DRAIN VALVE BOX SHALL BE PROPERLY SUPPORTED.
6. DRAIN PIPE FROM DRAIN PIT UP TO THE EXISTING DRAINAGE SYSTEM SHALL BE MADE OF UPVC, SCHEDULE 80 OR CLASS 150 CONFORMING TO ASTM D-1784 OR APPROVED EQUIVALENT.
7. F.O. STEEL PIPES WHICH ARE BURIED UNDERGROUND SHALL BE APPLIED WITH TAPE WRAPPING OF 1MM THICKNESS OR 6 MM THICKNESS OF ASPHALT JUTE. PRIOR TO APPLICATION OF TAPE, BITUMEN BASED PRIMER SHALL BE APPLIED TO PIPE, EXTERNAL SURFACES SHALL BE PRIMED WITH 2 COATS OF COAL TAR EPOXY POLYAMIDE OF 170 MICRONS PFT EACH COAT PRIOR TO APPLICATION OF ASPHALT JUTE.
8. THE CONTRACTOR SHALL SUPPLY FLEXIBLE HOSE NOT LESS THAN 50 MM AND 3 METERS LONG FITTED WITH STEEL PIPE NOT LESS THAN 50 MM & FOR HANDLING FUEL OIL FROM A 210 L DRAIN AND FLANGE CONNECTION AT F. O. TRANSFER PUMP SUCTION. THE FLEXIBLE HOSE SHALL BE MADE OF SYNTHETIC RUBBER TUBE, REINFORCED WITH SPIRAL-PLUED SYNTHETIC FABRIC WITH WIRE HELIX.

OWNER		<b>NATIONAL POWER CORPORATION</b> AGHAM ROAD, DILIMAN, QUEZON CITY	
PROJECT: SUPPLY, DELIVERY, INSTALLATION AND TEST OF 1200 KL AND 2000 KL FOST FOR PATNAMUNGAN DPP, PALAMAN DPP AND JORALIS DPP INCLUDING CONSTRUCTION OF ASSOCIATED FACILITIES UNDER PACKAGE I LOCATION: PATNAMUNGAN, QUEZON			
TITLE: <b>FUEL OIL STORAGE AND TRANSFER SYSTEM</b> <b>P AND I DIAGRAM</b> <b>1 X 35 KL FOST PATNAMUNGAN DPP</b>			
DESIGNED BY	CHKD	DATE	SUBMITTED BY
DRAWN			<i>R. M. C. SAWAN</i>
REVIEWED			RECOMMENDED BY
DATE			<i>E. N. RODRIGUEZ</i>
BY			APPROVED BY
			<i>G. B. MAGPOC, JR.</i>
DWS. NO. PaDPP-BDM-17.003		SPEC. NO. LuzP20Z11795e	
SCALE: NTS		BID DRAWING	
REV.	DATE	NAIURE OF REVISION	BY

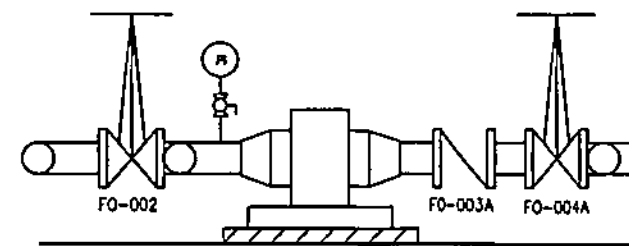

FUEL OIL TRANSFER PUMP  
(FO02PMP) 10 M<sup>3</sup>/HR, 30M

SECTION A-A

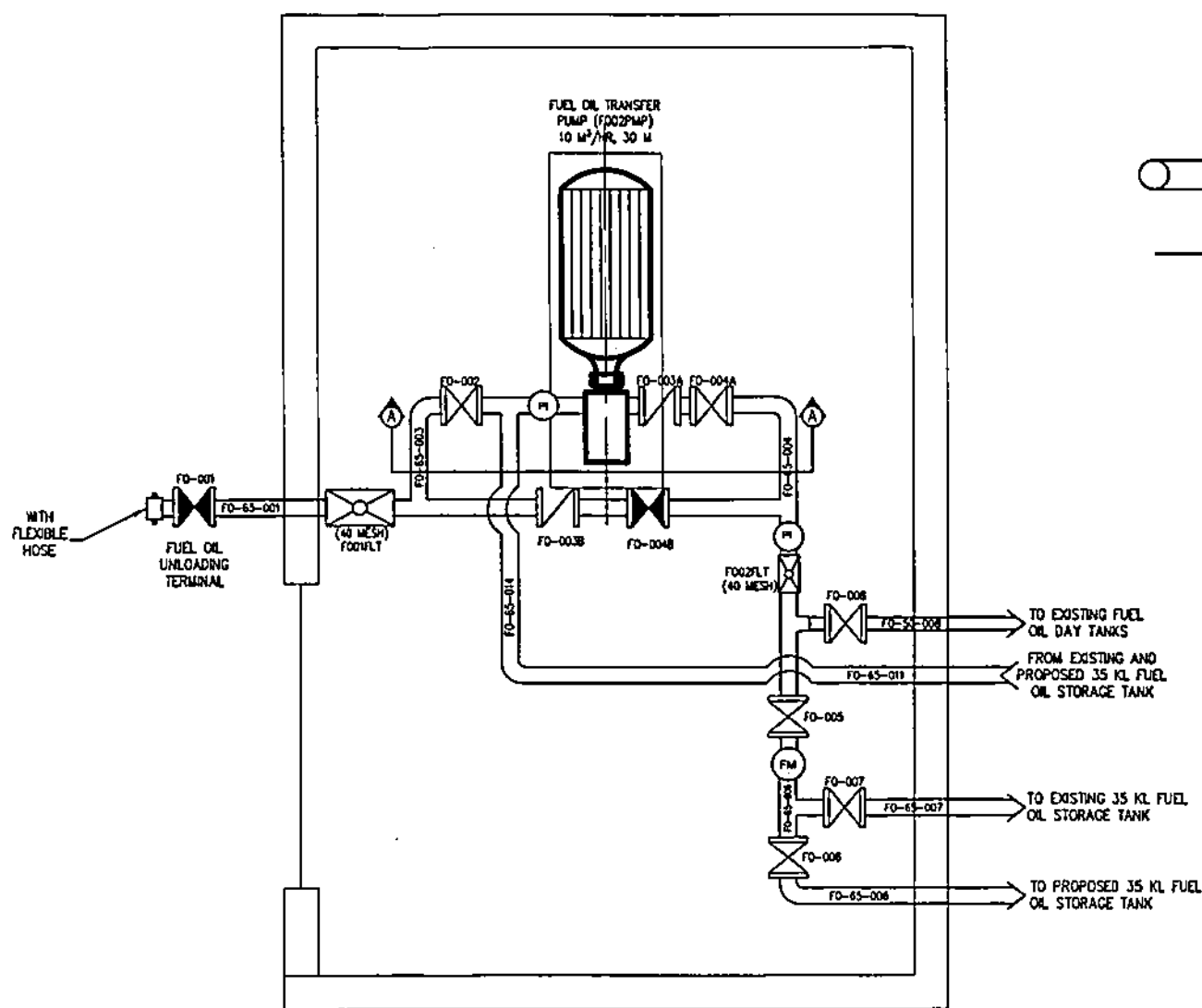

LEGEND:

- - GLOBE VALVE
- ◻ - GLOBE VALVE (NORMALLY CLOSED)
- ⊠ - BUTTERFLY VALVE W/ BOX
- ⊞ - GATE VALVE
- ⊞ - GATE VALVE (NORMALLY CLOSED)
- ∇ - CHECK VALVE
- - EXISTING EQUIPMENT/FACILITIES
- ▨ - FUEL FILTER
- ⊘ - REDUCER
- PI - PRESSURE GAUGE
- FI - FLOW INDICATOR
- FM - FLOW METER

NOTES:

1. ALL DIMENSIONS ARE IN MILLIMETERS UNLESS OTHERWISE SPECIFIED.
2. WORK THIS DRAWING WITH THE RELEVANT P&ID DIAGRAM.
3. PIPING MATERIALS SHALL CONFORM TO THE REQUIREMENTS OF THE TECHNICAL SPECIFICATIONS.
4. THE CONTRACTOR SHALL SUBMIT FINAL ARRANGEMENT AND DETAIL FOR NPC APPROVAL. THE ARRANGEMENT SHOWN IS FOR REFERENCE ONLY AND MAY BE MODIFIED BASED ON ACTUAL DIMENSIONS OF THE EQUIPMENT TO BE SUPPLIED BY THE CONTRACTOR.
5. THE CONTRACTOR SHALL FURNISH ALL CABLES REQUIRED FROM POWER SUPPLY SOURCE INSIDE THE POWER STATION TO THE PUMPHOUSE INCLUDING CIRCUIT BREAKER, CONDUITS AND OTHER NECESSARY ACCESSORIES IN ACCORDANCE WITH THE RELEVANT ELECTRICAL SPECIFICATION.
6. PIPING FROM/TO F.O. STORAGE TANK UNLOADING PIPE AND SUPPLY LINE TO EXISTING F. O. DAY TANKS WITHIN THE PUMPHOUSE SHALL BE REARRANGED/ADJUSTED DEPENDING ON THE ACTUAL EQUIPMENT ARRANGEMENT SHOWN ON PLAN DRAWINGS OF THE PLANT SITE.
7. TWO (2) WAY SWITCHES (PUMPHOUSE AND POWERHOUSE) SHALL BE PROVIDED FOR STARTING/STOPPING F.O. TRANSFER PUMP.
8. REFER TO CIVIL DRAWINGS FOR THE DETAILS OF PUMPHOUSE AND PIPE TERMINAL.

OWNER:		<b>NATIONAL POWER CORPORATION</b> AGHAM ROAD, CILIMAN, QUEZON CITY	
PROJECT: SUPPLY, DELIVERY, INSTALLATION AND TEST OF 1X35 KL AND 7X35 KL POST FOR PATNAHUNGAN DPP, PALANAN DPP, AND JORALIS DPP INCLUDING CONSTRUCTION OF ASSOCIATED FACILITIES UNDER PACKAGE 1			
LOCATION: PATNAHUNGAN, QUEZON			
TITLE:		<b>FUEL OIL PUMPHOUSE AND PIPING LAYOUT</b> PATNAHUNGAN DPP	
DESIGNED	BY	CHKD	DATE
DRAWN	MAN		
DESIGNED	PRINCIPAL ENGR. JARCYT.		RECOMMENDED:
CHKD			RECOMMENDED:
ELDG			APPROVED:
IN CH	JTC		
DPP NO: P-10PP-SDM-17.004		SPEC NO: LuzP202417504	

REV.	DATE	DESCRIPTION	BY	CHKD	REL. AUTH.

BID DRAWING

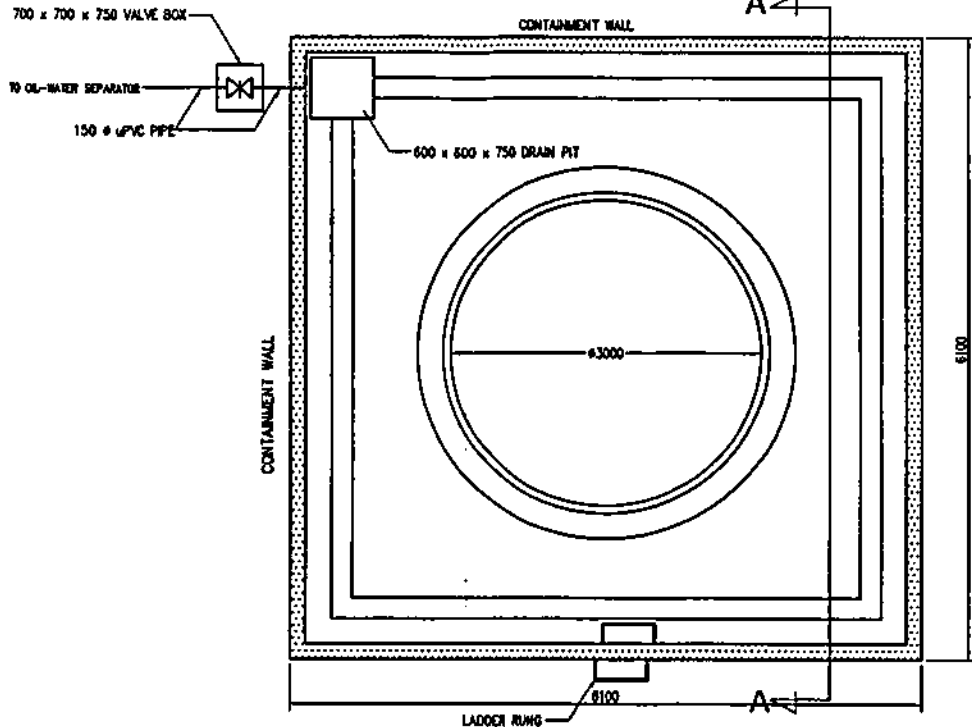

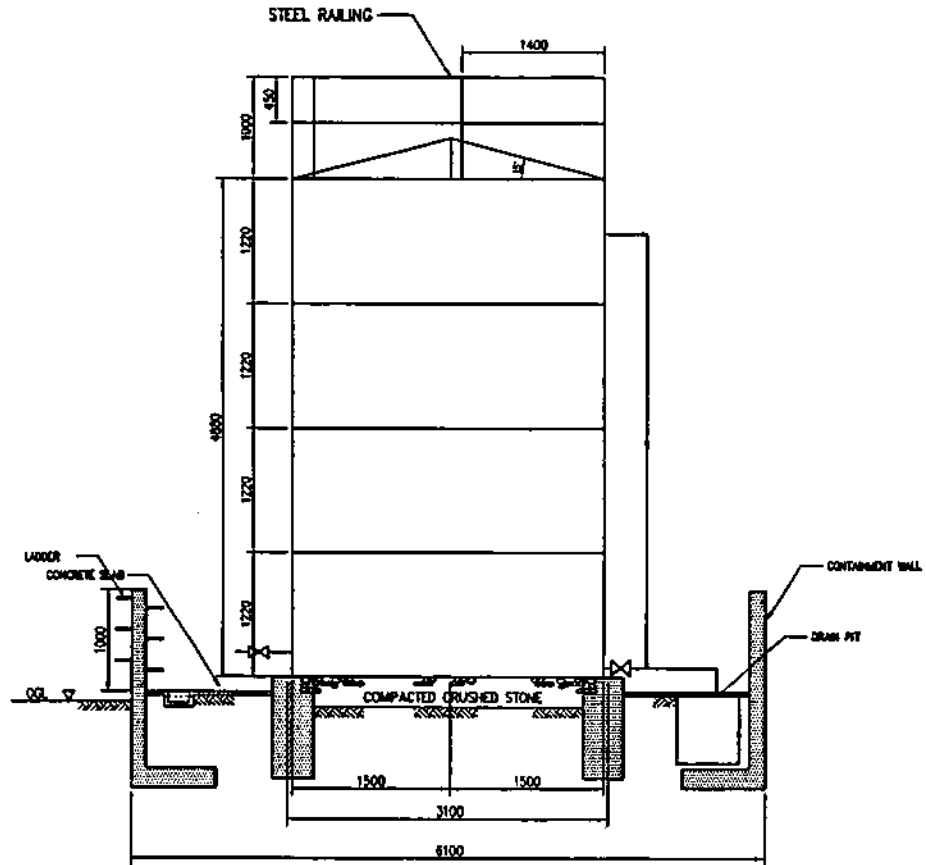

**PLAN (FUEL STORAGE TANK)**



**SECTION A-A**

**LEGEND :**

-  - BUTTERFLY VALVE W/ BOX
-  - GATE VALVE (NORMALLY CLOSED)
-  - GATE VALVE (NORMALLY OPENED)

**NOTES:**

1. ALL DIMENSIONS ARE IN MILLIMETERS UNLESS OTHERWISE SPECIFIED.
2. REFER TO CIVIL DRAWINGS FOR THE DETAILS OF TANK FOUNDATION, CONTAINMENT WALL, DRAIN PIT/DITCH AND CONTAINMENT ACCESS LADDER.
3. VERTICAL LADDER OF THE TANK SHALL BE PROVIDED WITH SAFETY CAGE AS SHOWN ON DETAILED DRAWINGS.
4. REFER TO DRAWINGS NOS. PKG135-BDM-17.001 TO D09 FOR DETAILS OF TANK APPURTENANCES.

 <b>NATIONAL POWER CORPORATION</b> AGHAM ROAD, DILIMAN, QUEZON CITY																																				
PROJECT: SUPPLY, DELIVERY, INSTALLATION AND TEST OF 1X35 KL AND 2X60 KL FOST FOR PATHANUNGAN DPP, PALANAN DPP, AND JORALIG DPP INCLUDING CONSTRUCTION OF ASSOCIATED FACILITIES UNDER PACKAGE 1 LOCATION: PATHANUNGAN, QUEZON																																				
<b>TITLE</b> <b>PLAN AND SECTION</b> <b>1X35 KL FOST PATHANUNGAN DPP</b>																																				
<table border="1" style="width: 100%; border-collapse: collapse;"> <tr> <th>DESIGNED</th> <th>BY</th> <th>CHKD</th> <th>DATE</th> </tr> <tr> <td> </td> <td> </td> <td> </td> <td> </td> </tr> <tr> <th>DRAWN</th> <th>MAN</th> <th>CHKD</th> <th>DATE</th> </tr> <tr> <td> </td> <td> </td> <td> </td> <td> </td> </tr> <tr> <th>REVIEWED</th> <th>PRINCIPAL ENGR./ARCHT.</th> <th>RECOMMENDED</th> <th>DATE</th> </tr> <tr> <td> </td> <td> </td> <td> </td> <td> </td> </tr> <tr> <th>CIVIL/ARCHT</th> <th>ELEC</th> <th>MECH</th> <th>DATE</th> </tr> <tr> <td> </td> <td> </td> <td> </td> <td> </td> </tr> </table>	DESIGNED	BY	CHKD	DATE					DRAWN	MAN	CHKD	DATE					REVIEWED	PRINCIPAL ENGR./ARCHT.	RECOMMENDED	DATE					CIVIL/ARCHT	ELEC	MECH	DATE					<table border="1" style="width: 100%; border-collapse: collapse;"> <tr> <td>           AUTHORIZED PROJECT A  <b>R. D. CABRAWAN</b>            PROJECT MANAGER         </td> </tr> <tr> <td> <b>A. N. RODRIGUEZ</b>            PROJECT ENGINEER         </td> </tr> <tr> <td> <b>G. S. MAGSINO, JR.</b>            DEPT. MANAGER - DDD         </td> </tr> </table>	AUTHORIZED PROJECT A <b>R. D. CABRAWAN</b> PROJECT MANAGER	<b>A. N. RODRIGUEZ</b> PROJECT ENGINEER	<b>G. S. MAGSINO, JR.</b> DEPT. MANAGER - DDD
DESIGNED	BY	CHKD	DATE																																	
DRAWN	MAN	CHKD	DATE																																	
REVIEWED	PRINCIPAL ENGR./ARCHT.	RECOMMENDED	DATE																																	
CIVIL/ARCHT	ELEC	MECH	DATE																																	
AUTHORIZED PROJECT A <b>R. D. CABRAWAN</b> PROJECT MANAGER																																				
<b>A. N. RODRIGUEZ</b> PROJECT ENGINEER																																				
<b>G. S. MAGSINO, JR.</b> DEPT. MANAGER - DDD																																				
DWG NO. <b>PatDPP-BDM-17.005</b> SPEC. NO. <b>LuzP20Z1179S0</b>																																				
<b>SCALE AS SHOWN</b> <b>BID DRAWING</b> REV. <b>0</b>																																				

REV.	DATE	NATURE OF REVISION	BY	CHKD	RECD	APPL.

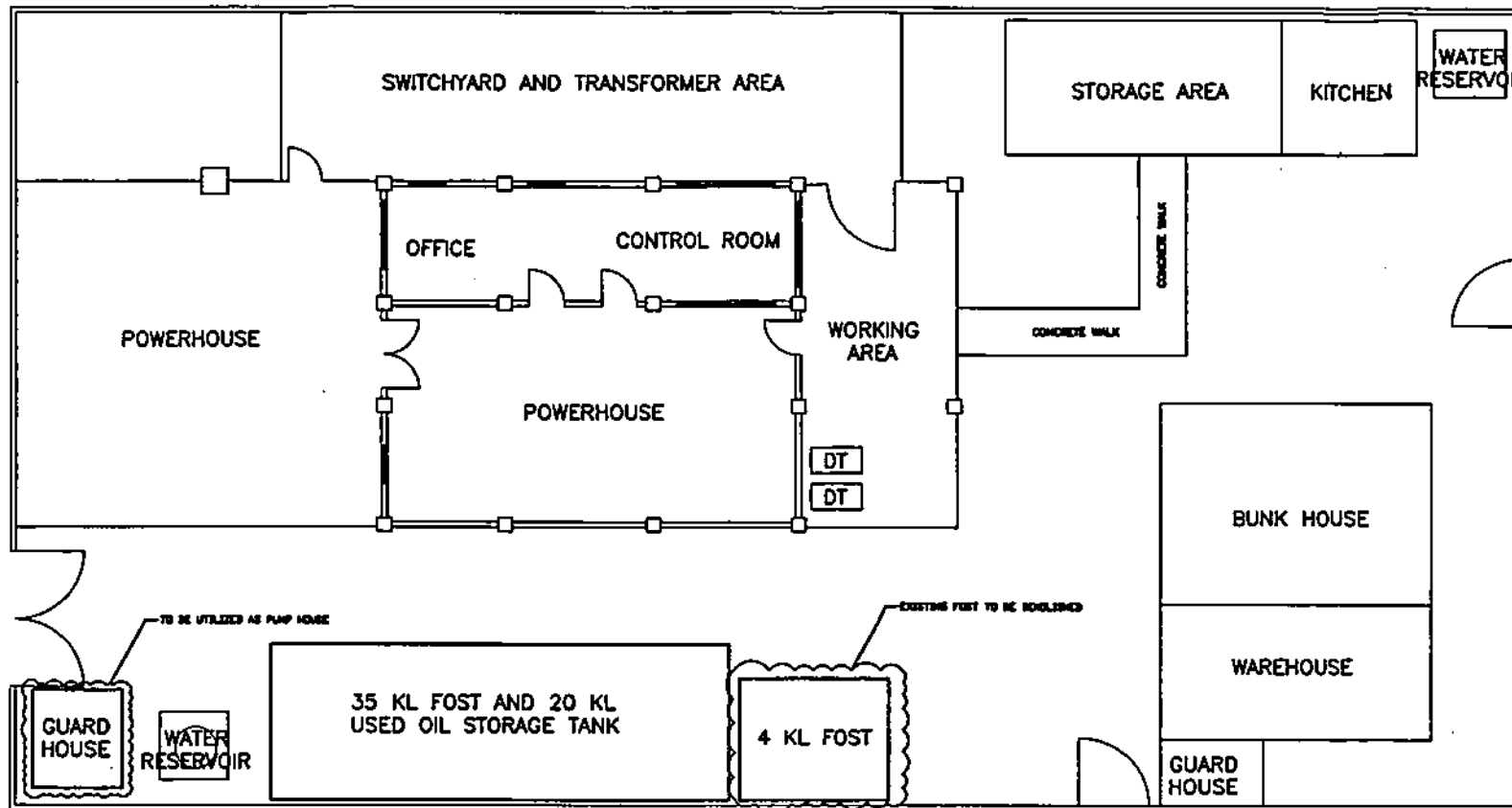

**NOTES:**

1. THIS DRAWING IS FOR REFERENCE PURPOSES ONLY.
2. ALL DIMENSIONS ARE IN MILLIMETERS UNLESS OTHERWISE SPECIFIED.
3. THE DIMENSION SHOWN MAY BE ADJUSTED BASED ON THE ACTUAL DIMENSION OF THE EQUIPMENT TO BE SUPPLIED BY THE CONTRACTOR.
4. WORK THIS DRAWING WITH APPLICABLE CIVIL AND ELECTRICAL DRAWINGS.

OWNER		 <b>NATIONAL POWER CORPORATION</b> AGHAM ROAD, DILIMAN, QUEZON CITY	
PROJECT: SUPPLY, DELIVERY, INSTALLATION AND TEST OF 1200 KL AND 2300 KL FOST FOR PATRAMUNGAN DPP, PALANAN DPP, AND JORMALIG DPP INCLUDING CONSTRUCTION OF ASSOCIATED FACILITIES UNDER PACKAGE 1 LOCATION: PALANAN, BARCELONA			
TITLE: <b>EXISTING EQUIPMENT/PLANT LAYOUT</b> <b>1X60 KL FOST PALANAN DPP</b>			
DESIGNED	BY	CHKD	DATE
DRAWN	BY		
REVIEWED	PRINCIPAL ENGR. / ARCHT.	RECOMMENDED	
CYCLARMENT			
ELEC.		APPROVED	
UPON	BY		
DWA NO P&IDPP-BDM-17.001		SPECS NO. LUZP20Z1179So	
SCALE: 1:150		DIO DRAWING	

REV	DATE	NATURE OF REVISION	BY	CHKD	RECD	APPR

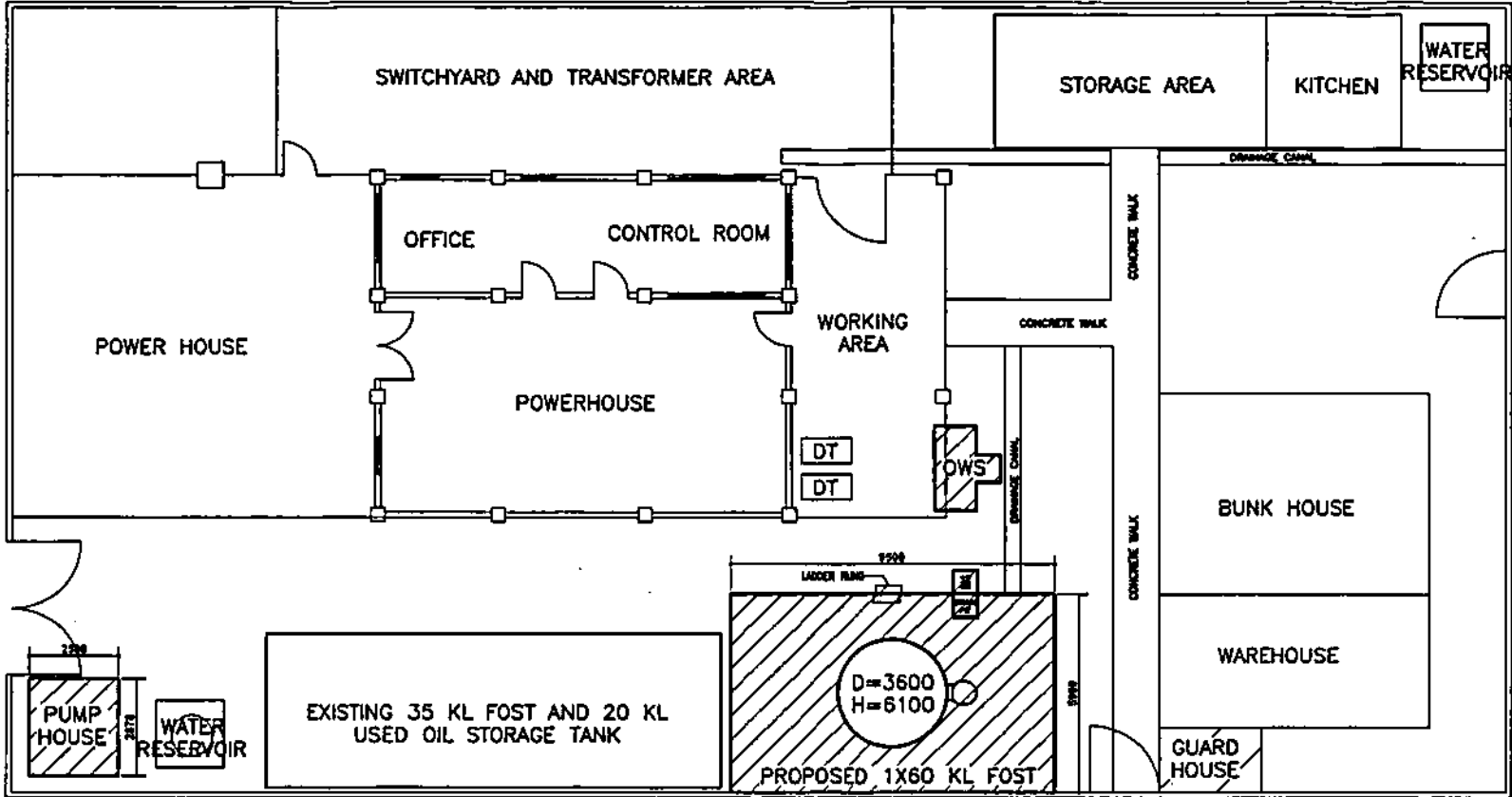

**LEGEND:**

- PROPOSED EQUIPMENT/FACILITY
- EXISTING EQUIPMENT/FACILITY
- BUTTERFLY VALVE W/ BOX
- DT - DAY TANK
- OWS - OIL-WATER SEPARATOR
- FOST - FUEL OIL STORAGE TANK

**NOTES:**

1. THIS DRAWING IS FOR REFERENCE PURPOSES ONLY.
2. ALL DIMENSIONS ARE IN MILLIMETERS UNLESS OTHERWISE SPECIFIED.
3. THE CONTRACTOR SHALL SUBMIT DESIGN CALCULATIONS AND FOUNDATION DETAILS FOR ALL EQUIPMENT TO BE SUPPLIED UNDER THIS SCOPE FOR APPROVAL OF NPC. E.G. FUEL OIL TRANSFER PUMP.
4. THE DIMENSION SHOWN MAY BE ADJUSTED BASED ON THE ACTUAL DIMENSION OF THE EQUIPMENT TO BE SUPPLIED BY THE CONTRACTOR.
5. WORK THIS DRAWING WITH APPLICABLE CIVIL AND ELECTRICAL DRAWINGS.

<b>NATIONAL POWER CORPORATION</b> AGHAM ROAD, DILMAN, QUEZON CITY																																									
PROJECT: SUPPLY, DELIVERY, INSTALLATION AND TEST OF 1X60 KL AND 2X60 KL FOST FOR PATALANAN DPP, PALANAN DPP, AND JORNAL DPP INCLUDING CONSTRUCTION OF ASSOCIATED FACILITIES UNDER PACKAGE 1 LOCATION: PALANAN, MARILAO																																									
<b>TITLE: PROPOSED EQUIPMENT/PLANT LAYOUT</b> <b>1X60 KL FOST PALANAN DPP</b>																																									
<table border="1" style="width: 100%; border-collapse: collapse;"> <thead> <tr> <th>DESIGNED</th> <th>BY</th> <th>CHKD</th> <th>DATE</th> </tr> </thead> <tbody> <tr> <td> </td> <td> </td> <td> </td> <td> </td> </tr> <tr> <td> </td> <td> </td> <td> </td> <td> </td> </tr> <tr> <td> </td> <td> </td> <td> </td> <td> </td> </tr> <tr> <td> </td> <td> </td> <td> </td> <td> </td> </tr> <tr> <td> </td> <td> </td> <td> </td> <td> </td> </tr> <tr> <td> </td> <td> </td> <td> </td> <td> </td> </tr> <tr> <td> </td> <td> </td> <td> </td> <td> </td> </tr> </tbody> </table>	DESIGNED	BY	CHKD	DATE																													<table border="1" style="width: 100%; border-collapse: collapse;"> <tr> <td style="text-align: right;">SUBMITTED:</td> <td style="text-align: left;"></td> </tr> <tr> <td style="text-align: right;">RECOMMENDED:</td> <td style="text-align: left;"></td> </tr> <tr> <td style="text-align: right;">APPROVED:</td> <td style="text-align: left;"></td> </tr> <tr> <td style="text-align: right;">ME-21</td> <td style="text-align: left;">JTC</td> </tr> </table>	SUBMITTED:		RECOMMENDED:		APPROVED:		ME-21	JTC
DESIGNED	BY	CHKD	DATE																																						
SUBMITTED:																																									
RECOMMENDED:																																									
APPROVED:																																									
ME-21	JTC																																								
DWG. NO. <b>PaIDPP-BDM-17.002</b> SPEC. NO. <b>LUZP20Z1179Sg</b>																																									
SCALE: 1:150 <b>BID DRAWING</b> REV. 0																																									

DATE	BY	CHKD	RECD	APPR

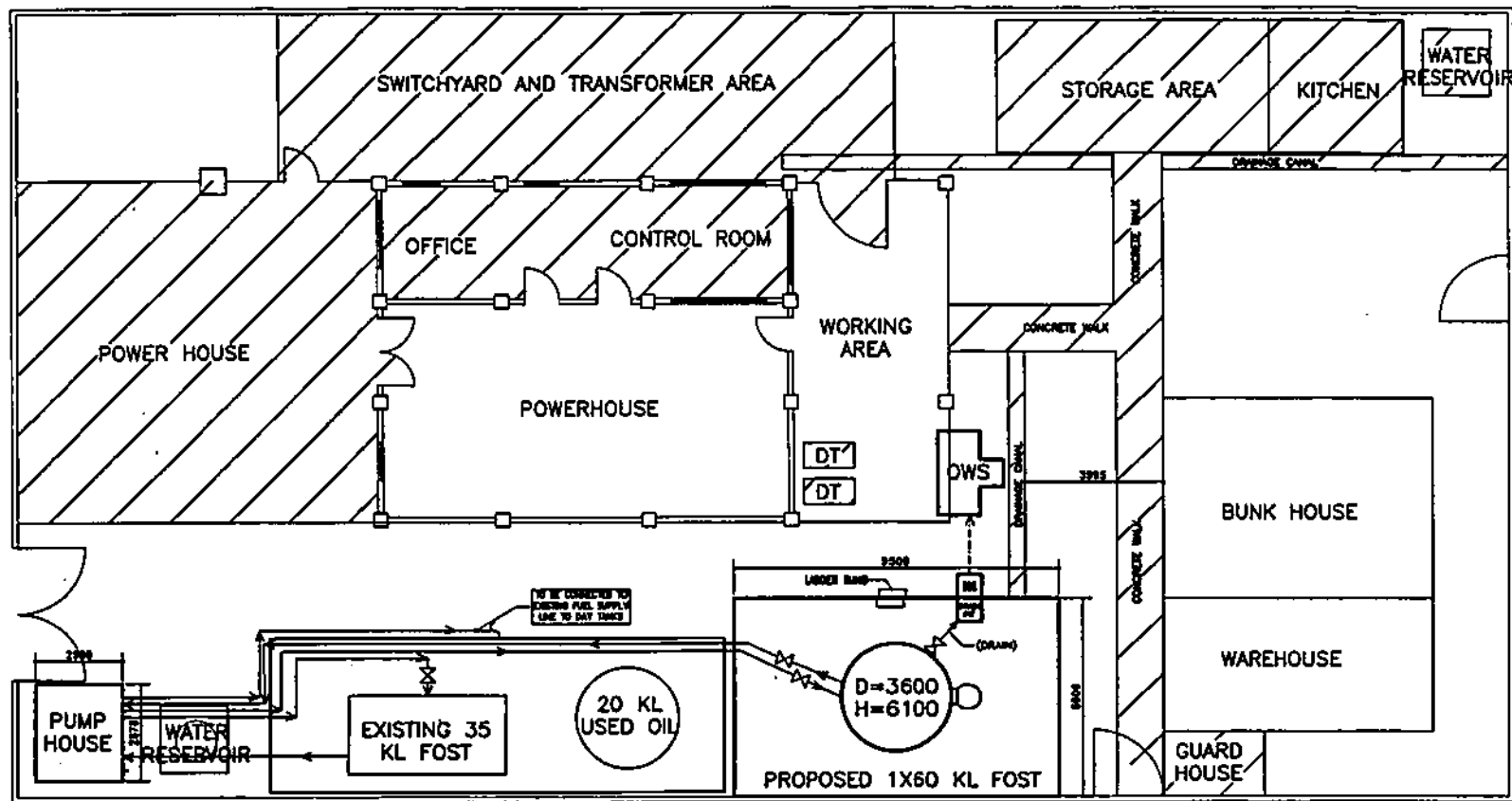

**LEGEND:**

- EXISTING EQUIPMENT/FACILITY
- PROPOSED EQUIPMENT/FACILITY
- BUTTERFLY VALVE W/ BOX
- GATE VALVE
- GATE VALVE (NORMALLY CLOSED)
- REDUCER
- FLEXIBLE HOSE
- DT - DAY TANK
- OWS - OIL-WATER SEPARATOR
- FOST - FUEL OIL STORAGE TANK

**NOTES:**

1. THIS DRAWING IS FOR REFERENCE PURPOSES ONLY.
2. ALL DIMENSIONS ARE IN MILLIMETERS UNLESS OTHERWISE SPECIFIED.
3. ALL EQUIPMENT SHOWN IN THIS DRAWING SHALL BE SUPPLIED, CONSTRUCTED, TESTED AND COMMISSIONED BY THE CONTRACTOR.
4. EQUIPMENT AND PIPING ARRANGEMENT MAY BE ADJUSTED TO SUIT ACTUAL SITE CONDITIONS.
5. REFER TO CIVIL DRAWINGS FOR THE DETAILS OF CIVIL STRUCTURES FACILITIES INCLUDING EQUIPMENT FOUNDATION AND TRENCH.
6. FUEL PIPE SHALL BE GENERALLY INSTALLED ABOVEGROUND. WHERE INSTALLATION IS REQUIRED UNDERGROUND, MINIMUM DEPTH OF EMBEDDED PIPES SHALL BE NOT LESS THAN 300 MM IN OPEN GROUNDS AND 400 MM UNDER ROADWAYS. FOR PIPES THAT CROSSES ROADWAY, PIPE SLEEVE OF STEEL MATERIALS OR RSC SHALL BE PROVIDED. REFER ALSO TO TYPICAL PIPE SUPPORTS DRAWINGS FOR REFERENCE.
7. LOCAL PANEL SHALL BE PROVIDED EACH AT THE FUEL PUMPHOUSE AND IN THE POWERHOUSE (SEE ELECTRICAL DRAWINGS). EACH LOCAL PANEL SHALL BE PROVIDED WITH START AND STOP PUSH BUTTONS WITH RESPECTIVE STATUS INDICATING LIGHTS. LOCAL PANEL AT THE PUMPHOUSE SHALL BE PROVIDED WITH LOCAL/REMOTE SELECTOR SWITCH.



**NATIONAL POWER CORPORATION**  
AGHAM ROAD, DILIMAN, QUEZON CITY

PROJECT: SUPPLY, DELIVERY, INSTALLATION AND TEST OF 1200 KL AND 2500 KL FOST FOR PATRAMUNGAN DPP, PALAMAN DPP, AND JOMALIG DPP INCLUDING CONSTRUCTION OF ASSOCIATED FACILITIES UNDER PACKAGE 1

LOCATION: PALAMAN, SAMBLA

TITLE: **FUEL OIL STORAGE AND PIPING LAYOUT**  
1x60 KL FOST PALAMAN DPP

DESIGNED	BY	CHKD	DATE	SUBMITTED	 R. M. CEBASAN G. B. MAGPOC JR. DATE: 10/13/10
DRAWN	MAN			RECOMMENDED	
REVIEWED	PRINCIPAL ENGR./ARCHT.			APPROVED	
CIVIL/ARCHT					
BLEC					
MECH	ITC				

DWG NO. P2DPP-BOM-17.003      SPEC NO. LUP20Z1179Sg

SCALE: 1:150

**BID DRAWING**

REV. 0

REV.	DATE	NATURE OF REVISION	BY	CHKD	APCD	APPR.



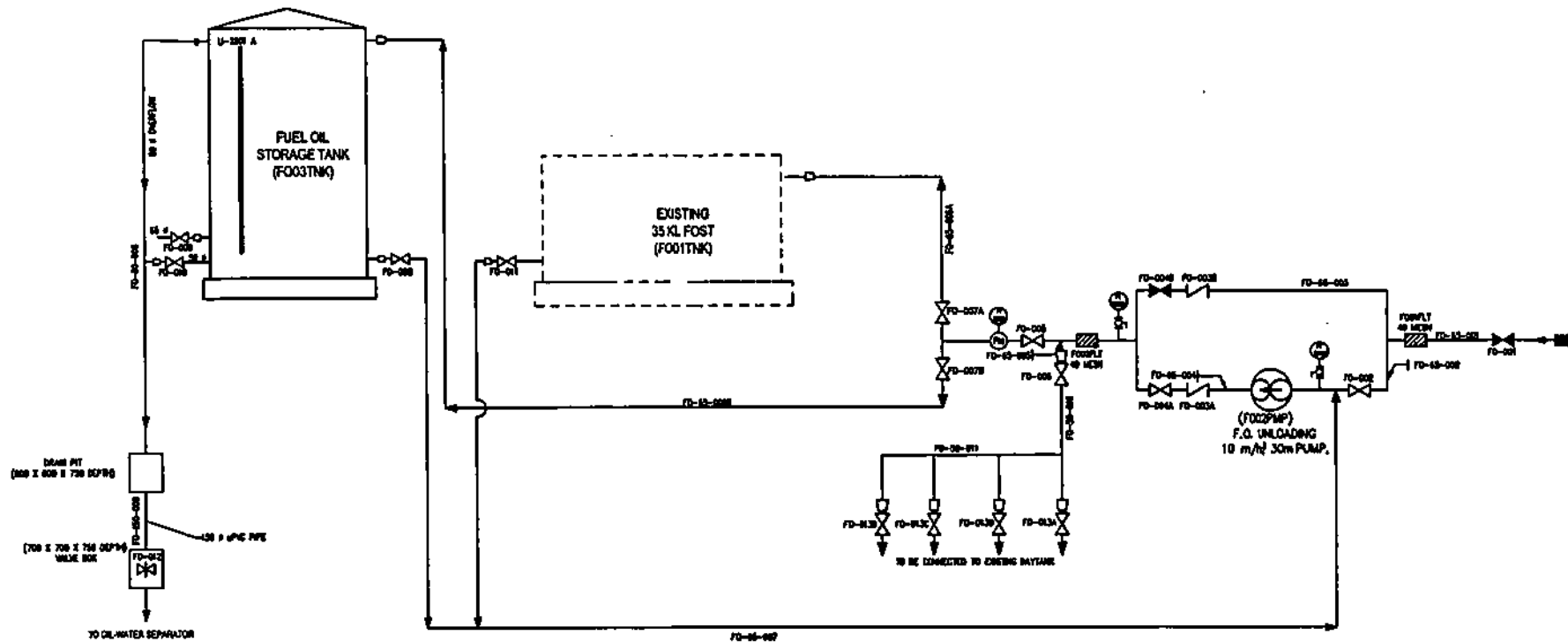

**NOTES:**

1. ALL DIMENSIONS ARE IN MILLIMETERS UNLESS OTHERWISE SPECIFIED.
2. ALL PIPING, PIPE SUPPORTS AND FITTINGS, VALVES AND ACCESSORIES SHALL BE SUPPLIED, INSTALLED AND TESTED BY THE CONTRACTOR. PIPES ARE GENERALLY INSTALLED ABOVE GROUND UNLESS OTHERWISE SHOWN ON THE DRAWING. PIPES TO BE INSTALLED UNDERGROUND SHALL BE NOT LESS THAN 300 MM DEPTH.
3. FUEL OIL PIPES SHALL CONFORM TO ASTM A53 GR. B, SEAMLESS PIPE AND SCHEDULE 40, MATERIALS FOR VALVES 65MM AND ABOVE SHALL BE CAST IRON AND CAST BRONZE FOR 50 MM AND BELOW.
4. REFER TO CIVIL DRAWINGS FOR THE DETAILED DRAWINGS OF TANK FOUNDATION/CONTAINMENT WALL, DRAIN PIT AND VALVE BOX.
5. VALVE INSIDE DRAIN VALVE BOX SHALL BE PROPERLY SUPPORTED.
6. DRAIN PIPE FROM DRAIN PIT UP TO THE EXISTING DRAINAGE SYSTEM SHALL BE MADE OF UPIC, SCHEDULE 80 OR CLASS 150 CONFORMING TO ASTM D-1784 OR APPROVED EQUIVALENT.
7. F.O. STEEL PIPES WHICH ARE BURIED UNDERGROUND SHALL BE APPLIED WITH TAPE WRAPPING OF 1MM THICKNESS OR 8 MM THICKNESS OF ASPHALT JUTE. PRIOR TO APPLICATION OF TAPE, BITUMEN BASED PRIMER SHALL BE APPLIED TO PIPE, EXTERNAL SURFACES OR SHALL BE PRIMED WITH 2 COATS OF COAL TAR EPOXY POLYAMIDE OF 170 MICRONS PFT EACH COAT PRIOR TO APPLICATION OF ASPHALT JUTE.
8. THE CONTRACTOR SHALL SUPPLY FLEXIBLE HOSE NOT LESS THAN 50 MM AND 3 METERS LONG FITTED WITH STEEL PIPE NOT LESS THAN 50 MM Ø FOR HANDLING FUEL OIL FROM A 210 L DRUM AND FLANGE CONNECTION AT F. O. TRANSFER PUMP SUCTION. THE FLEXIBLE HOSE SHALL BE MADE OF SYNTHETIC RUBBER TUBE, REINFORCED WITH SPIRAL-PLIED SYNTHETIC FABRIC WITH WIRE HELD.

**LEGEND:**

- GLOBE VALVE
- GLOBE VALVE (NORMALLY CLOSED)
- BUTTERFLY VALVE W/ BOX
- GATE VALVE
- GATE VALVE (NORMALLY CLOSED)
- CHECK VALVE
- EXISTING EQUIPMENT/FACILITIES
- FUEL FILTER
- REDUCER
- PRESSURE GAUGE
- FLOW INDICATOR
- FLOW METER
- FLEXIBLE HOSE

**PIPE DESIGNATION LEGEND:**

- FO - 65 - 003
- SYSTEM (FUEL)
- NOMINAL PIPE SIZE (DIAMETER)
- SEQUENCE NO.

OWNER:		NATIONAL POWER CORPORATION AGHAM ROAD, DILMAN, QUEZON CITY	
PROJECT: SUPPLY, DELIVERY, INSTALLATION AND TEST OF 1X35 KL AND 2X50 KL FOST FOR PATRAMUNGAN DPP, PALAMAN DPP, AND JONALIS DPP INCLUDING CONSTRUCTION OF ASSOCIATED FACILITIES UNDER PACKAGE 1			
LOCATION: PALAMAN, ISABELA			
TITLE: FUEL OIL STORAGE AND TRANSFER SYSTEM P AND I DIAGRAM 1X35 KL FOST PALAMAN DPP			
DESIGNED	BY	CHKD	DATE
DRAWN	MAN		
REVIEWED	PRINCIPAL ENGR./ARCHT.	RECOMMENDED:	R. M. CADSAWAN Principal Engineer & A. N. RODRIGUEZ District Engineer
APPROVED:	G. B. MACPAG JR. District Manager - DPP		
DWG. NO. P-DPP-BDM-17.004		SPEC. NO. LUZP20Z11793g	
SCALE: NTS		BID DRAWING	

NO.	DATE	NATURE OF REVISION	BY	CHKD	RECD	APPD.

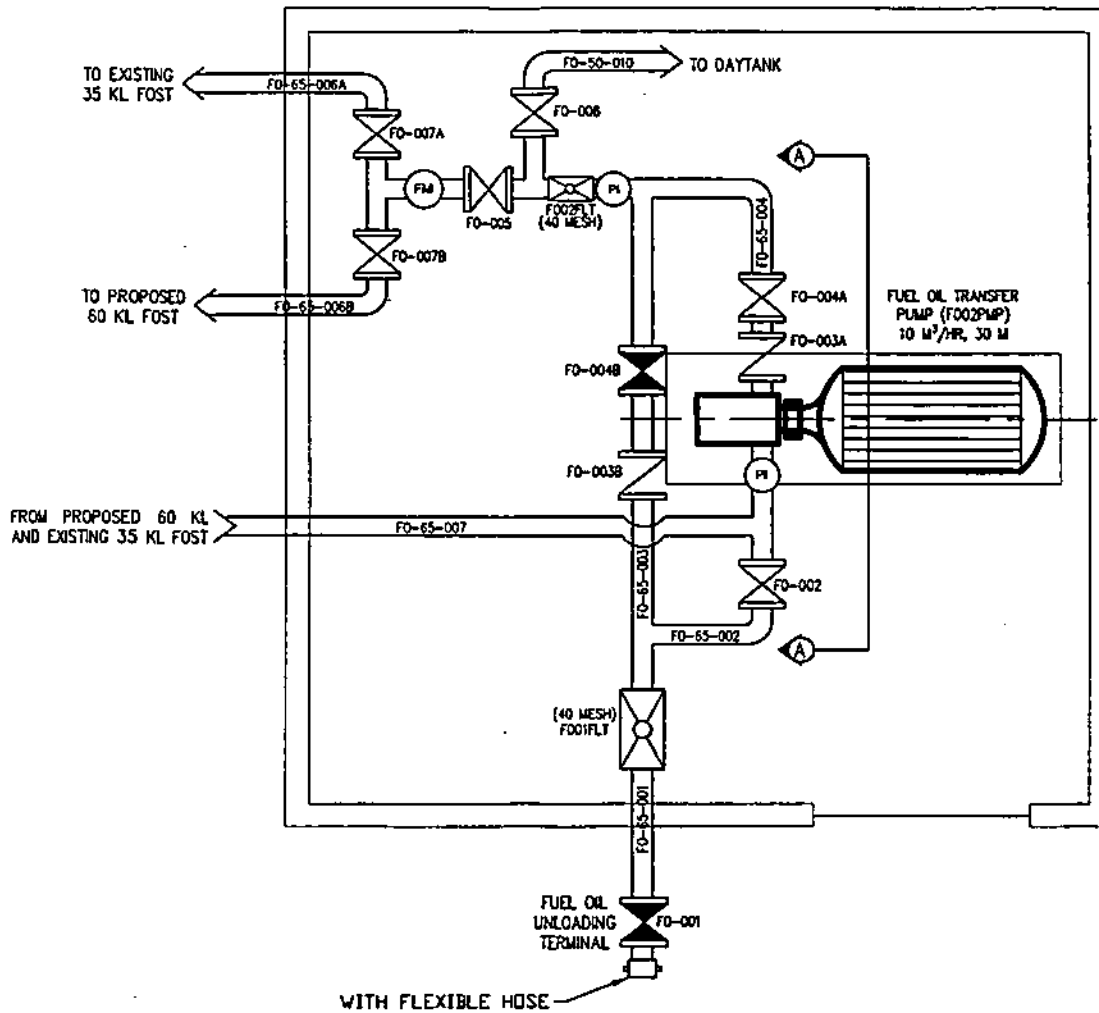

### FUEL OIL PUMPHOUSE

#### LEGEND :

- FUEL FILTER
- GATE VALVE
- GATE VALVE (NORMALLY CLOSED)
- GLOBE VALVE
- CHECK VALVE
- PRESSURE GAUGE
- FLOW METER

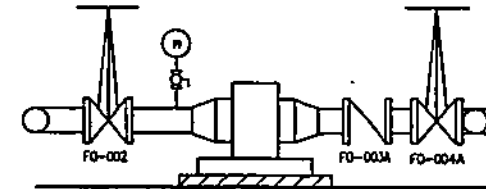

FUEL OIL TRANSFER PUMP  
(FO02PMP) 10 M<sup>3</sup>/HR, 30M

#### SECTION A-A

#### NOTES:

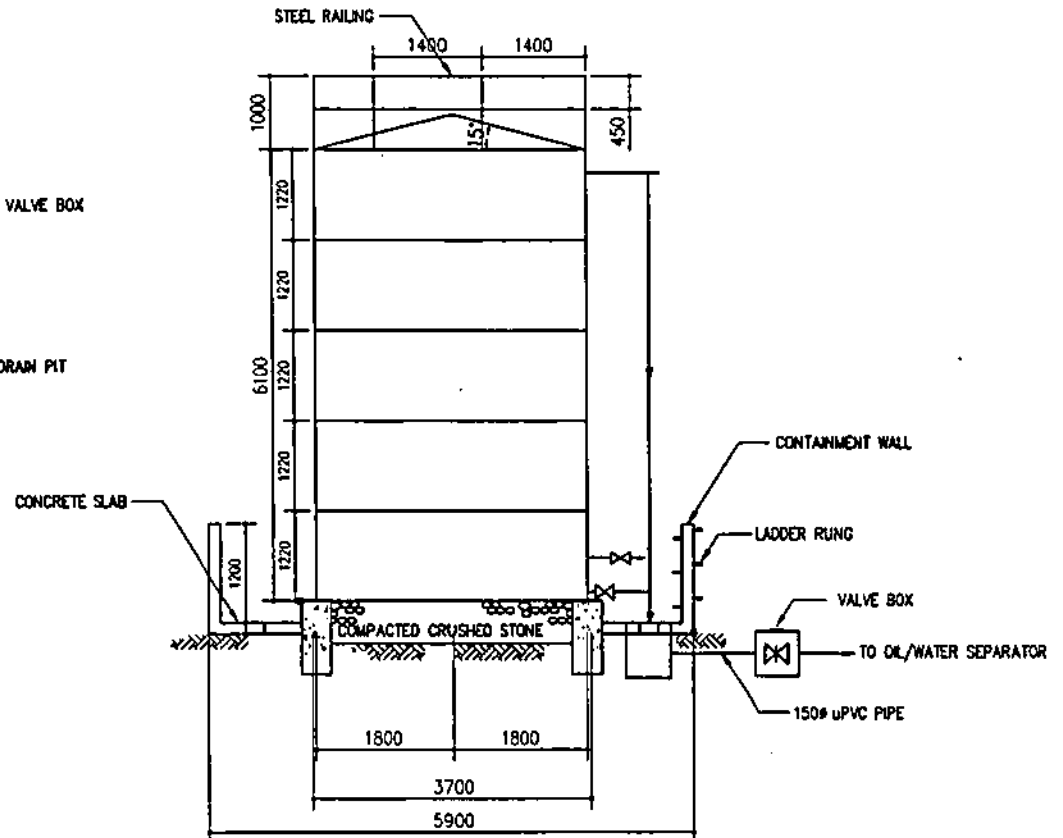
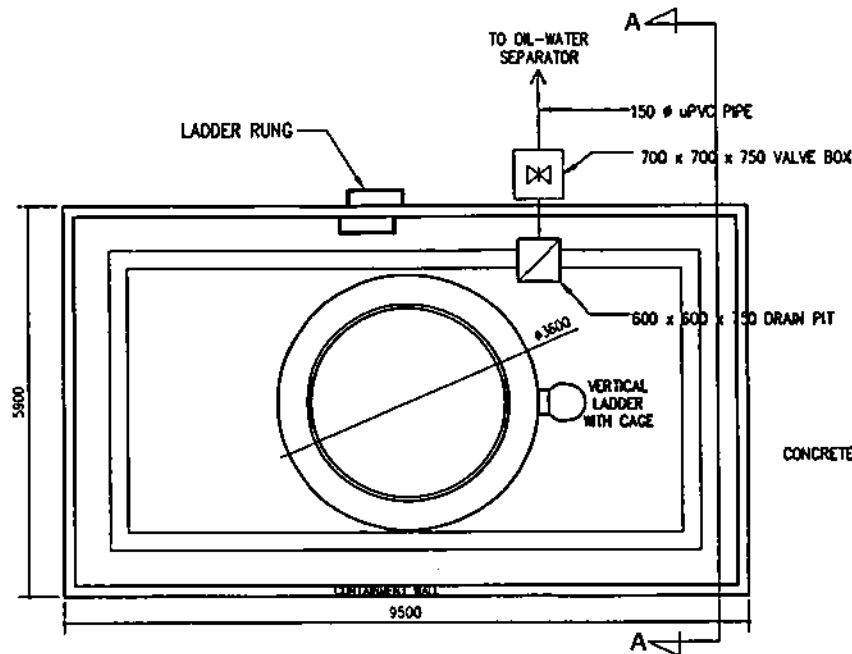

- ALL DIMENSIONS ARE IN MILLIMETERS UNLESS OTHERWISE SPECIFIED.
- WORK THIS DRAWING WITH THE RELEVANT P&ID DRAWING.
- PIPING MATERIALS SHALL CONFORM TO THE REQUIREMENTS OF THE TECHNICAL SPECIFICATIONS.
- THE CONTRACTOR SHALL SUBMIT FINAL ARRANGEMENT AND DETAIL FOR MPC APPROVAL. THE ARRANGEMENT SHOWN IS FOR REFERENCE ONLY AND MAY BE MODIFIED BASED ON ACTUAL DIMENSIONS OF THE EQUIPMENT TO BE SUPPLIED BY THE CONTRACTOR.
- THE CONTRACTOR SHALL FURNISH ALL CABLES REQUIRED FROM POWER SUPPLY SOURCE INSIDE THE POWER STATION TO THE PUMPHOUSE INCLUDING CIRCUIT BREAKER, CONDUITS AND OTHER NECESSARY ACCESSORIES IN ACCORDANCE WITH THE RELEVANT ELECTRICAL SPECIFICATION.
- PIPING FROM/TO F.O. STORAGE TANK, UNLOADING PIPE AND SUPPLY LINE TO EXISTING F. O. DAY TANKS WITHIN THE PUMPHOUSE SHALL BE REARRANGED/ADJUSTED DEPENDING ON THE ACTUAL EQUIPMENT ARRANGEMENT SHOWN ON PLAN DRAWINGS OF THE PLANT SITE.
- TWO (2) WAY SWITCHES (PUMPHOUSE AND POWERHOUSE) SHALL BE PROVIDED FOR STARTING/STOPPING F.O. TRANSFER PUMP.
- REFER TO CIVIL DRAWINGS FOR THE DETAILS OF PUMPHOUSE AND PIPE TERMINAL.

OWNER:		NATIONAL POWER CORPORATION AGHAM ROAD, DELIMAN, QUEZON CITY	
PROJECT: SUPPLY, DELIVERY, INSTALLATION AND TEST OF 1X60 KL AND 2X30 KL FOST FOR PATERMUNGAN DPP, PALANAN DPP, AND JOSEALDO DPP INCLUDING CONSTRUCTION OF ASSOCIATED FACILITIES UNDER PACKAGE 1			
LOCATOR: PALANAN, BAMBALA			
TITLE: <b>FUEL OIL PUMPHOUSE AND PIPING LAYOUT</b> 1X60 KL FOST PALANAN DPP			
DESIGNED	BY	CHKD	DATE
DRAWN	BY	CHKD	DATE
REVIEWED	PRINCIPAL ENGR. / ARCHT.		RECOMMENDED:
CIVIL/ARCHT			
ELEC.			APPROVED:
MECH.	ITC		
DWG. NO. PalDPP-ED-17.005		SPEC. NO. LuzP2021179S	
SCALE AS SHOWN		BID DRAWING	
REV.		DATE	
NATURE OF REVISION		BY	
		CHKD	
		RECD	
		APPR.	



SECTION A-A

LEGEND :

-  - BUTTERFLY VALVE W/ BOX
-  - GATE VALVE (NORMALLY CLOSED)
-  - GATE VALVE (NORMALLY OPENED)

NOTES:

1. ALL DIMENSIONS ARE IN MILLIMETERS UNLESS OTHERWISE SPECIFIED.
2. REFER TO CIVIL DRAWINGS FOR THE DETAILS OF TANK FOUNDATION, CONTAINMENT WALL, DRAIN PIT/DITCH AND CONTAINMENT ACCESS LADDER.
3. VERTICAL LADDER OF EACH TANK SHALL BE PROVIDED WITH SAFETY CAGE AS SHOWN ON DETAILED DRAWINGS.
4. REFER TO DRAWINGS NOS. PKG160-SDM-17.001 TO 006 FOR DETAILS OF TANK APPURTENANCES.

OWNER				NATIONAL POWER CORPORATION AGHAM ROAD, DILIMAN, QUEZON CITY	
PROJECT: SUPPLY, DELIVERY, INSTALLATION AND TEST OF 1320 KL AND 2000 KL POND FOR PATANANGAN DPP, PALAMAS DPP, AND JOBALIS DPP INCLUDING CONSTRUCTION OF ASSOCIATED FACILITIES UNDER PACKAGE 1					
LOCATION: PALAMAS, MARBELA					
TITLE <b>PLAN AND SECTION</b> 1X86 KL FOST PALAMAS DPP					
DESIGNED	BY	CHKD	DATE	SUBMITTER	<i>[Signature]</i> R. M. ROSAWAN
DRAWN	BY			RECOMMENDED	<i>[Signature]</i> A. N. RODRIGUEZ
REVIEWED	PRINCIPAL ENGR. / FRONT			APPROVED	<i>[Signature]</i> G. B. MACPOE JR.
CHECKED					
B.E.C.					
RECD					
DWS NO. P&DPP-EDM-17.006			SPEC. NO. LUZP20Z117350		
SCALE AS SHOWN			BID DRAWING		REV. 0

REV.	DATE	NATURE OF REVISION	BY	CHKD	RECD	APPD

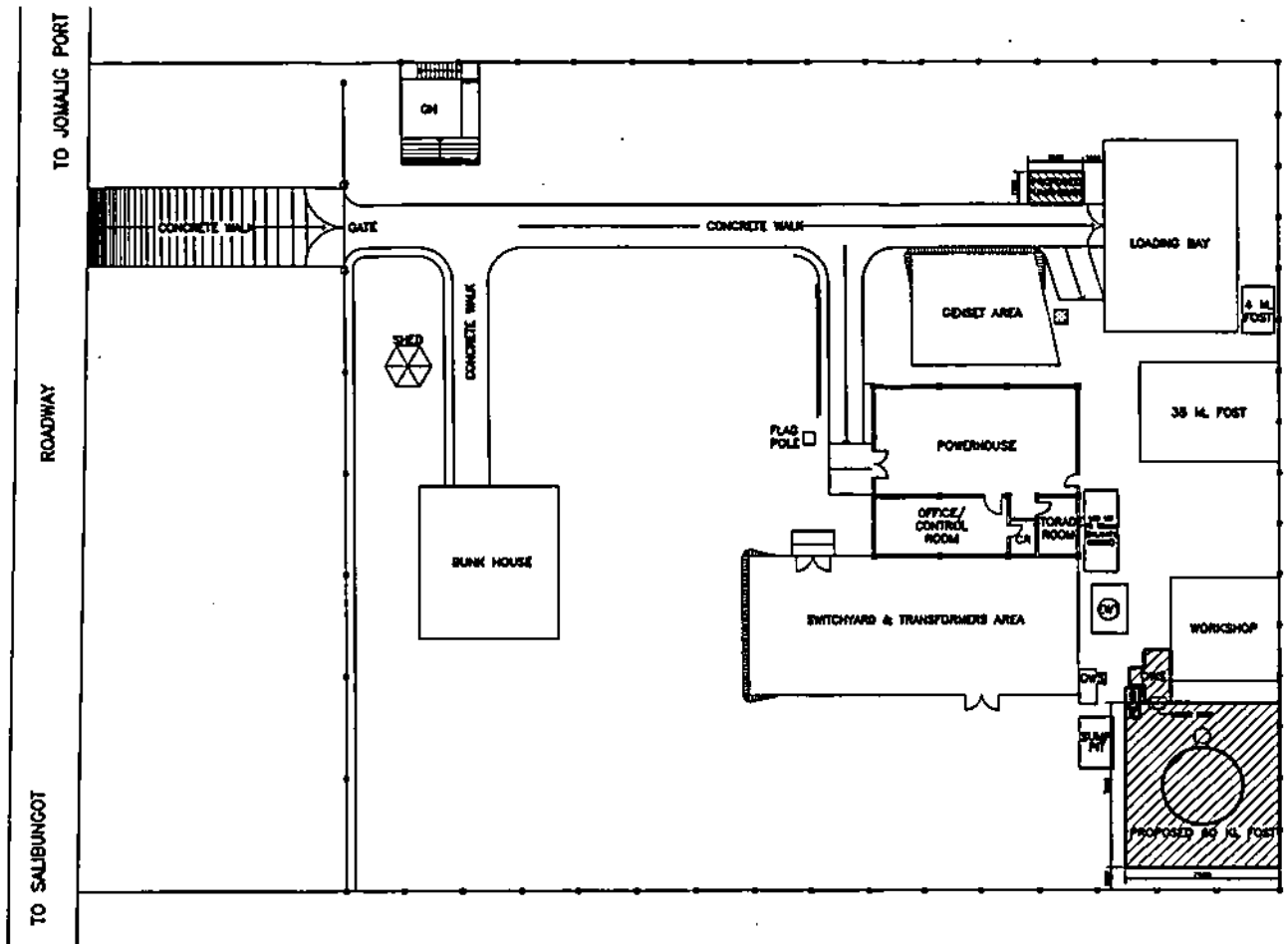

- LEGEND:**
- PROPOSED EQUIPMENT/FACILITY
  - EXISTING EQUIPMENT/FACILITY
  - BUTTERFLY VALVE W/ BOX
  - GATE VALVE
  - DP - DRAIN PIT
  - OWS - OIL-WATER SEPARATOR
  - FOST - FUEL OIL STORAGE TANK
  - EWT - ELEVATED WATER TANK
  - GH - GUARD HOUSE

- NOTES:**
1. THIS DRAWING IS FOR REFERENCE PURPOSES ONLY.
  2. ALL DIMENSIONS ARE IN MILLIMETERS UNLESS OTHERWISE SPECIFIED.
  3. THE CONTRACTOR SHALL SUBMIT DESIGN CALCULATIONS AND FOUNDATION DETAILS FOR ALL EQUIPMENT TO BE SUPPLIED UNDER THIS SCOPE FOR APPROVAL OF NPC. E.G. FUEL OIL TRANSFER PUMP.
  4. THE DIMENSION SHOWN MAY BE ADJUSTED BASED ON THE ACTUAL DIMENSION OF THE EQUIPMENT TO BE SUPPLIED BY THE CONTRACTOR.
  5. WORK THIS DRAWING WITH APPLICABLE CIVIL AND ELECTRICAL DRAWINGS.

OWNER:		NATIONAL POWER CORPORATION AGHAM ROAD, DILIMAN, QUEZON CITY	
PROJECT: SUPPLY, DELIVERY, INSTALLATION AND TEST OF 1X60 KL AND 2X60 KL FOST FOR PATRAMUNGUAN DPP, PALANAN DPP, AND JOMALIG DPP INCLUDING CONSTRUCTION OF ASSOCIATED FACILITIES UNDER PACKAGE 1			
LOCATION: JOMALIG, QUEZON			
TITLE:		EQUIPMENT/PLANT LAYOUT 1X60 KL FOST JOMALIG DPP	
DESIGNED	BY	CHKD	DATE
DRAWN	BY	CHKD	DATE
REVIEWED	BY	CHKD	DATE
APPROVED	BY	CHKD	DATE
SUBMITTED:		R. M. CALSAWAN	
RECOMMENDED:		A. N. RODRIGUEZ	
APPROVED:		G. B. MAGPOC JR.	
DEPT:		ELECTRICAL	

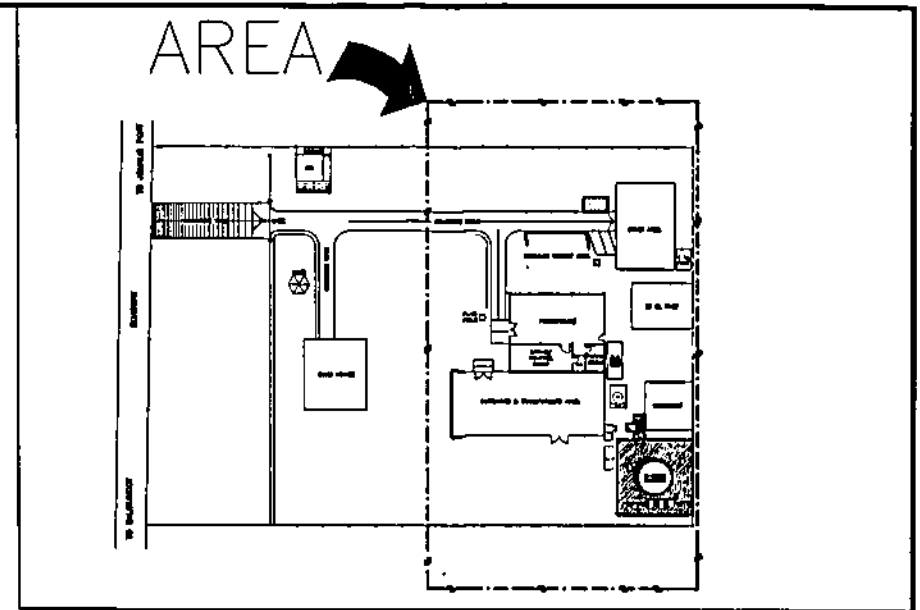
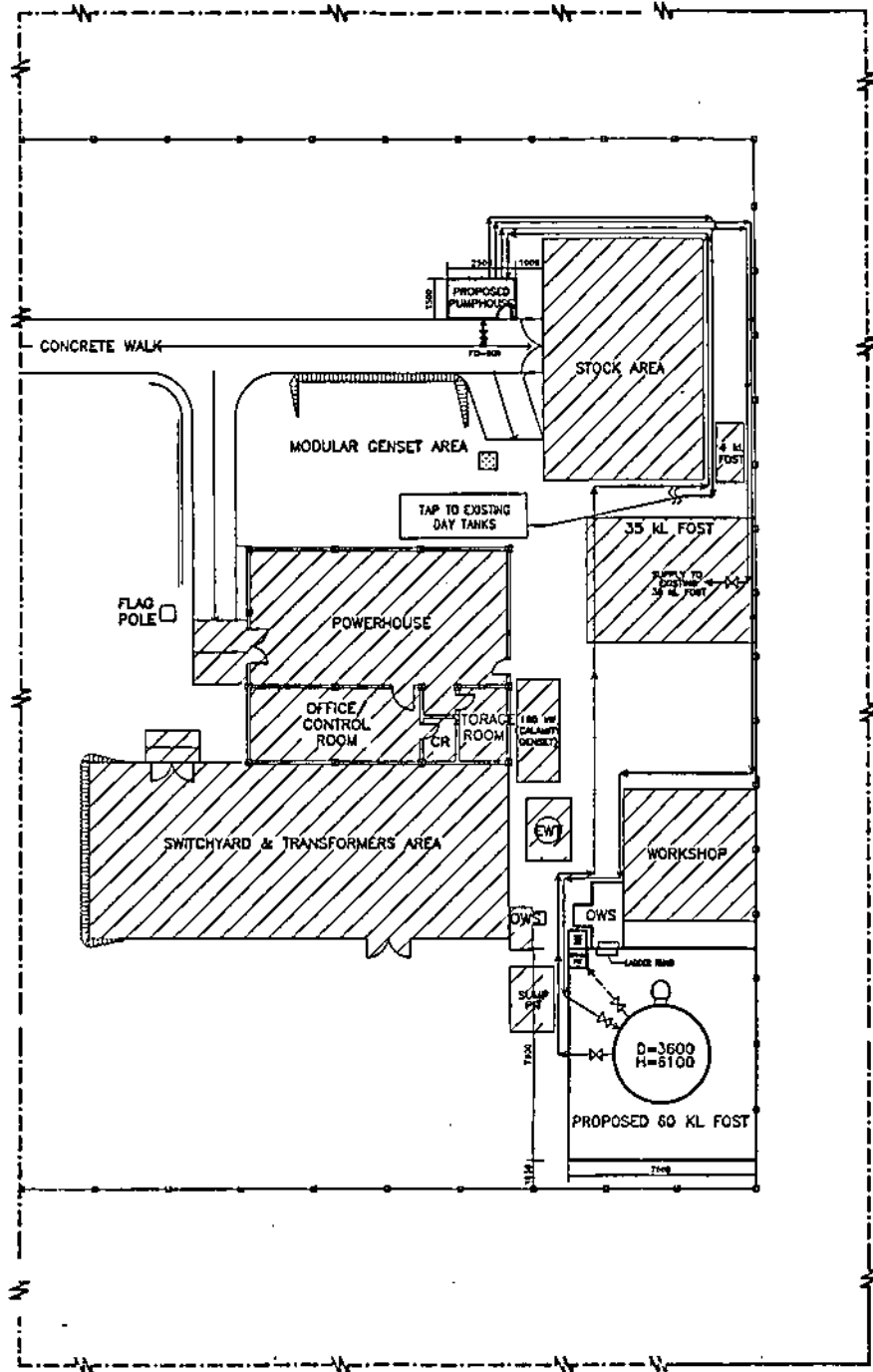

**NOTES:**

1. THIS DRAWING IS FOR REFERENCE PURPOSES ONLY.
2. ALL DIMENSIONS ARE IN MILLIMETERS UNLESS OTHERWISE SPECIFIED.
3. ALL EQUIPMENT SHOWN IN THIS DRAWING SHALL BE SUPPLIED, CONSTRUCTED, TESTED AND COMMISSIONED BY THE CONTRACTOR.
4. EQUIPMENT AND PIPING ARRANGEMENT MAY BE ADJUSTED TO SUIT ACTUAL SITE CONDITIONS.
5. REFER TO CIVIL DRAWINGS FOR THE DETAILS OF CIVIL STRUCTURES FACILITIES INCLUDING EQUIPMENT FOUNDATION AND TRENCH.
6. FUEL PIPE SHALL BE GENERALLY INSTALLED ABOVEGROUND. WHERE INSTALLATION IS REQUIRED UNDERGROUND, MINIMUM DEPTH OF EMBEDDED PIPES SHALL BE NOT LESS THAN 300 MM IN OPEN GROUNDS AND 400 MM UNDER ROADWAYS. FOR PIPES THAT CROSSES ROADWAY, PIPE SLEEVE OF STEEL MATERIALS OR RSC SHALL BE PROVIDED. REFER ALSO TO TYPICAL PIPE SUPPORTS DRAWINGS FOR REFERENCE.
7. LOCAL PANEL SHALL BE PROVIDED EACH AT THE FUEL PUMPHOUSE AND IN THE POWERHOUSE (SEE ELECTRICAL DRAWINGS). EACH LOCAL PANEL SHALL BE PROVIDED WITH START AND STOP PUSH BUTTONS WITH RESPECTIVE STATUS INDICATING LIGHTS. LOCAL PANEL AT THE PUMPHOUSE SHALL BE PROVIDED WITH LOCAL/REMOTE SELECTOR SWITCH.

**LEGEND:**

- EXISTING EQUIPMENT/FACILITY
- PROPOSED EQUIPMENT/FACILITY
- BUTTERFLY VALVE W/ BOX
- GATE VALVE
- GATE VALVE (NORMALLY CLOSED)
- REDUCER
- FLEXIBLE HOSE
- DRAIN PIT
- OIL-WATER SEPARATOR
- FUEL OIL STORAGE TANK
- ELEVATED WATER TANK

OWNER:		<b>NATIONAL POWER CORPORATION</b> ACHAM ROAD, DILIMAN, QUEZON CITY	
PROJECT: SUPPLY, DELIVERY, INSTALLATION AND TEST OF 1838 KL AND 2X38 KL FOST FOR PATABUNGAN DPP, PALANAN DPP, AND JOMALIG DPP INCLUDING CONSTRUCTION OF ASSOCIATED FACILITIES UNDER PACKAGE 1			
LOCATION: JOMALIG, QUEZON			
TITLE: <b>FUEL OIL STORAGE AND PIPING LAYOUT</b> 1X60 KL FOST JOMALIG DPP			
DESIGNED	BY	CHKD	DATE
DRAWN	MAN		
REVIEWED	PRINCIPAL ENGR./ARCHT.		SUBMITTED: <i>R. M. CADAWAN</i>
CIVIL/ARCHT			RECOMMENDED: <i>A. N. RODRIGUEZ</i>
ELEC			APPROVED: <i>G. B. MAGPOC JR.</i>
MECH	JTC		
DRAWING NO. JomDPP-CDM-17.002		ISSUE NO. LUP20211755	

REV.	DATE	REASON FOR REVISION	BY	CHKD	RECD.	APPR.
SCALE: 1:100						<b>BID DRAWING</b>

PIPE DESIGNATION LEGEND:

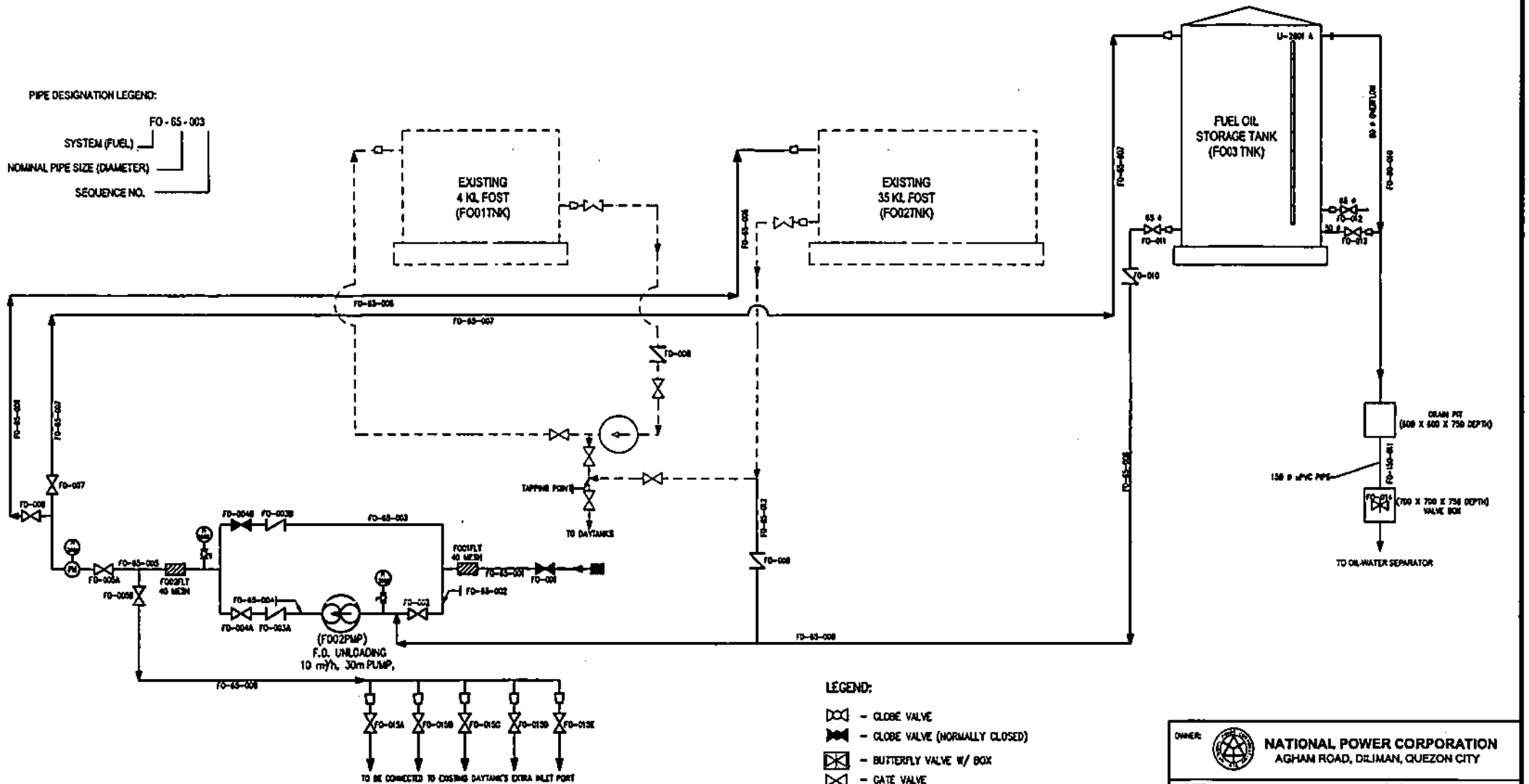
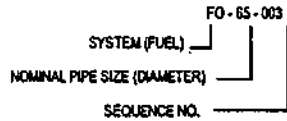

LEGEND:

- GLOBE VALVE
- GLOBE VALVE (NORMALLY CLOSED)
- BUTTERFLY VALVE W/ BOX
- GATE VALVE (NORMALLY CLOSED)
- CHECK VALVE
- EXISTING EQUIPMENT/FACILITIES
- FUEL FILTER
- REDUCER
- PRESSURE GAUGE
- FLOW INDICATOR
- FLOW METER
- FLEXIBLE HOSE

NOTES:

1. ALL DIMENSIONS ARE IN MILLIMETERS UNLESS OTHERWISE SPECIFIED.
2. ALL PIPING, PIPE SUPPORTS AND FITTINGS, VALVES AND ACCESSORIES SHALL BE SUPPLIED, INSTALLED AND TESTED BY THE CONTRACTOR. PIPES ARE GENERALLY INSTALLED ABOVE GROUND UNLESS OTHERWISE SHOWN ON THE DRAWING. PIPES TO BE INSTALLED UNDERGROUND SHALL BE NOT LESS THAN 300 MM DEPTH.
3. FUEL OIL PIPES SHALL CONFORM TO ASTM A53 OR B, SEAMLESS PIPE AND SCHEDULE 40. MATERIALS FOR VALVES 65MM# AND ABOVE SHALL BE CAST IRON AND CAST BRONZE FOR 50 MM # AND BELOW.
4. REFER TO CIVIL DRAWINGS FOR THE DETAILED DRAWINGS OF TANK FOUNDATION/CONTAINMENT WALL, DRAIN PIT AND VALVE BOX.
5. VALVE INSIDE DRAIN VALVE BOX SHALL BE PROPERLY SUPPORTED.
6. DRAIN PIPE FROM DRAIN PIT UP TO THE EXISTING DRAINAGE SYSTEM SHALL BE MADE OF UPVC, SCHEDULE 80 OR CLASS 150 CONFORMING TO ASTM D-1784 OR APPROVED EQUIVALENT.
7. F.O. STEEL PIPES WHICH ARE BURIED UNDERGROUND SHALL BE APPLIED WITH TAPE WRAPPING OF 1MM THICKNESS OR 8 MM THICKNESS OF ASPHALT JUTE. PRIOR TO APPLICATION OF TAPE, BITUMEN BASED PRIMER SHALL BE APPLIED TO PIPE. EXTERNAL SURFACES OR SHALL BE PRIMED WITH 2 COATS OF COAL TAR EPOXY POLYAMIDE OF 170 MICRONS PFT EACH COAT PRIOR TO APPLICATION OF ASPHALT JUTE.
8. THE CONTRACTOR SHALL SUPPLY FLEXIBLE HOSE NOT LESS THAN 50 MM# AND 3 METERS LONG FITTED WITH STEEL PIPE NOT LESS THAN 50 MM # FOR HANDLING FUEL OIL FROM A 210 L DRAIN AND FLANGE CONNECTION AT F. O. TRANSFER PUMP SUCTION. THE FLEXIBLE HOSE SHALL BE MADE OF SYNTHETIC RUBBER TUBE, REINFORCED WITH SPIRAL-PLUED SYNTHETIC FABRIC WITH WIRE HELIX.
9. THE CONTRACTOR SHALL REPLACE EXISTING FUEL SUPPLY PIPES, FITTINGS, VALVES AND ETC. FOR THE EXISTING 4 KL AND 35 KL FOST.

OWNER:				<b>NATIONAL POWER CORPORATION</b> AGHAM ROAD, DELIMAN, QUEZON CITY	
PROJECT: SUPPLY, DELIVERY, INSTALLATION AND TEST OF 1X25 KL AND 2X50 KL FOST FOR PATAMANGHAN OPP, PALAMAN OPP, AND JOMALIG OPP INCLUDING CONSTRUCTION OF ASSOCIATED FACILITIES UNDER PACKAGE 1					
LOCATION: JOMALIG, QUEZON					
TITLE: <b>FUEL OIL STORAGE AND TRANSFER SYSTEM</b> P AND I DIAGRAM 1X50 KL FOST JOMALIG DPP					
DESIGNED	BY	CHKD	DATE	SUBMITTED:	<i>R. M. CARRAWAY</i>
DRAWN	MAN			RECOMMENDED:	<i>A. N. RODRIGUEZ</i>
REVIEWED	PRINCIPAL ENGR/ARCHT.			APPROVED:	<i>G. B. MAGPOC JR.</i>
ENL/ARCHT					
BLCK					
MECH	JC				
DRAWING NO: JomDPP-BDM-17.003				SHEET NO. LUSP20Z1179S0	

REV.	DATE	SUMMARY OF REVISION	BY	CHKD	RECD.	APPD.

BID DRAWING

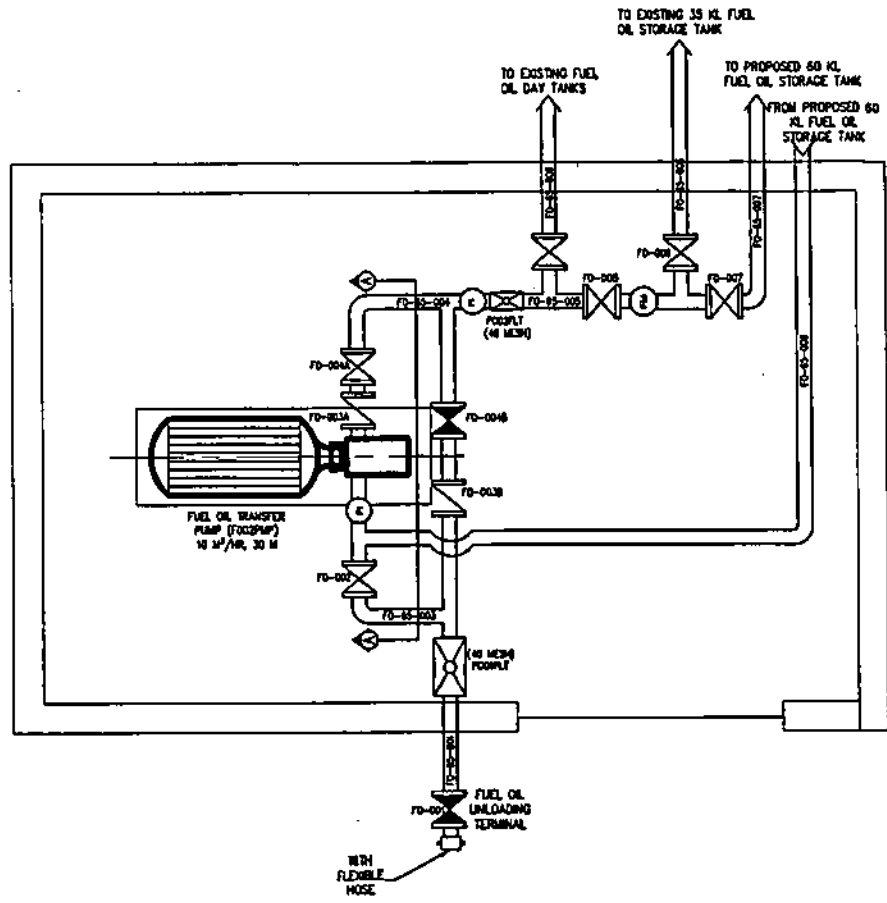

### FUEL OIL PUMPHOUSE

**NOTES:**

1. ALL DIMENSIONS ARE IN MILLIMETERS UNLESS OTHERWISE SPECIFIED.
2. WORK THIS DRAWING WITH THE RELEVANT P&ID DIAGRAM.
3. PIPING MATERIALS SHALL CONFORM TO THE REQUIREMENTS OF THE TECHNICAL SPECIFICATIONS.
4. THE CONTRACTOR SHALL SUBMIT FINAL ARRANGEMENT AND DETAIL FOR NPC APPROVAL. THE ARRANGEMENT SHOWN IS FOR REFERENCE ONLY AND MAY BE MODIFIED BASED ON ACTUAL DIMENSIONS OF THE EQUIPMENT TO BE SUPPLIED BY THE CONTRACTOR.
5. THE CONTRACTOR SHALL FURNISH ALL CABLES REQUIRED FROM POWER SUPPLY SOURCE INSIDE THE POWER STATION TO THE PUMPHOUSE INCLUDING CIRCUIT BREAKER, CONDUITS AND OTHER NECESSARY ACCESSORIES IN ACCORDANCE WITH THE RELEVANT ELECTRICAL SPECIFICATION.
6. PIPING FROM/TO F.O. STORAGE TANK, UNLOADING PIPE AND SUPPLY LINE TO EXISTING F. O. DAY TANKS WITHIN THE PUMPHOUSE SHALL BE REARRANGED/ADJUSTED DEPENDING ON THE ACTUAL EQUIPMENT ARRANGEMENT SHOWN ON PLAN DRAWINGS OF THE PLANT SITE.
7. TWO (2) WAY SWITCHES (PUMPHOUSE AND POWERHOUSE) SHALL BE PROVIDED FOR STARTING/STOPPING F.O. TRANSFER PUMP.
8. REFER TO CIVIL DRAWINGS FOR THE DETAILS OF PUMPHOUSE AND PIPE TERMINAL.

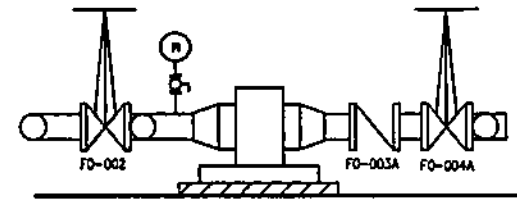

FUEL OIL TRANSFER PUMP (FO02PMP) 10 M<sup>3</sup>/HR, 30M

### SECTION A

**LEGEND :**

- FUEL FILTER
- GATE VALVE
- GATE VALVE (NORMALLY CLOSED)
- GLOBE VALVE
- CHECK VALVE
- PRESSURE GAUGE
- FLOW METER

OWNER:				NATIONAL POWER CORPORATION AGHAM ROAD, DALIMAN, QUEZON CITY	
PROJECT: SUPPLY, DELIVERY, INSTALLATION AND TEST OF 1X35 KL AND 2X60 KL FOST FOR PATNABANGAM OPP, PALAMAN OPP, AND JOMALIG OPP INCLUDING CONSTRUCTION OF ASSOCIATED FACILITIES UNDER PACKAGE 1					
LOCATION: JOMALIG, QUEZON					
TITLE: FUEL OIL PUMPHOUSE AND PIPING LAYOUT 1X35 KL FOST JOMALIG DPP					
DESIGNED:	BY:	CHKD:	DATE:	SUBMITTED:	<i>R.M. CANSAYAN</i>
DRAWN:	WAP:			RECOMMENDED:	<i>A.N. RODRIGUEZ</i>
REVIEWED:	PRINCIPAL ENGR. / ARCHT.			APPROVED:	<i>G. B. MAGPOC JR.</i>
CHECKED:					
SCALE:	1/2"				
JMS No. JomDPP-BDM-17.004		DPP No. LuzP20Z1179Se			
SCALE AS SHOWN		3/2 DRAWING		REV. 0	

REV.	DATE	NATURE OF REVISION	BY	CHKD	RECD	APPA

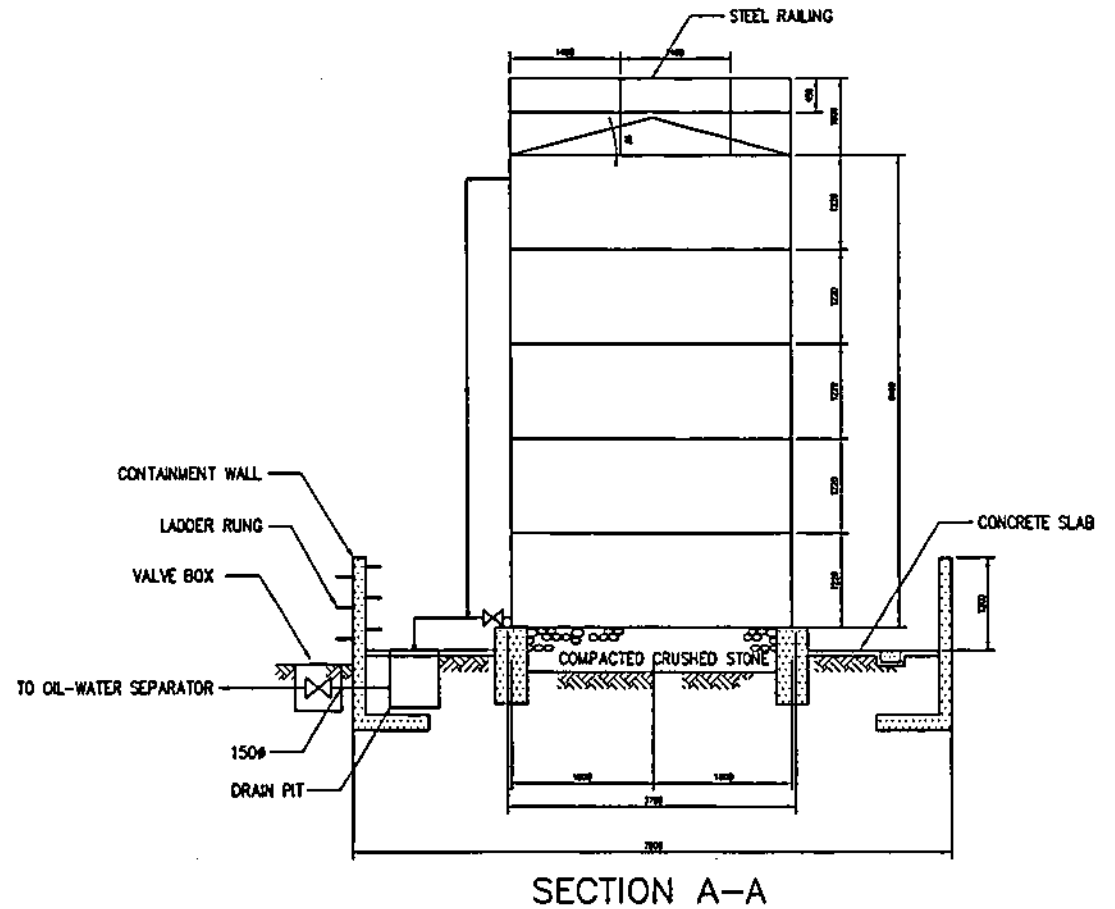
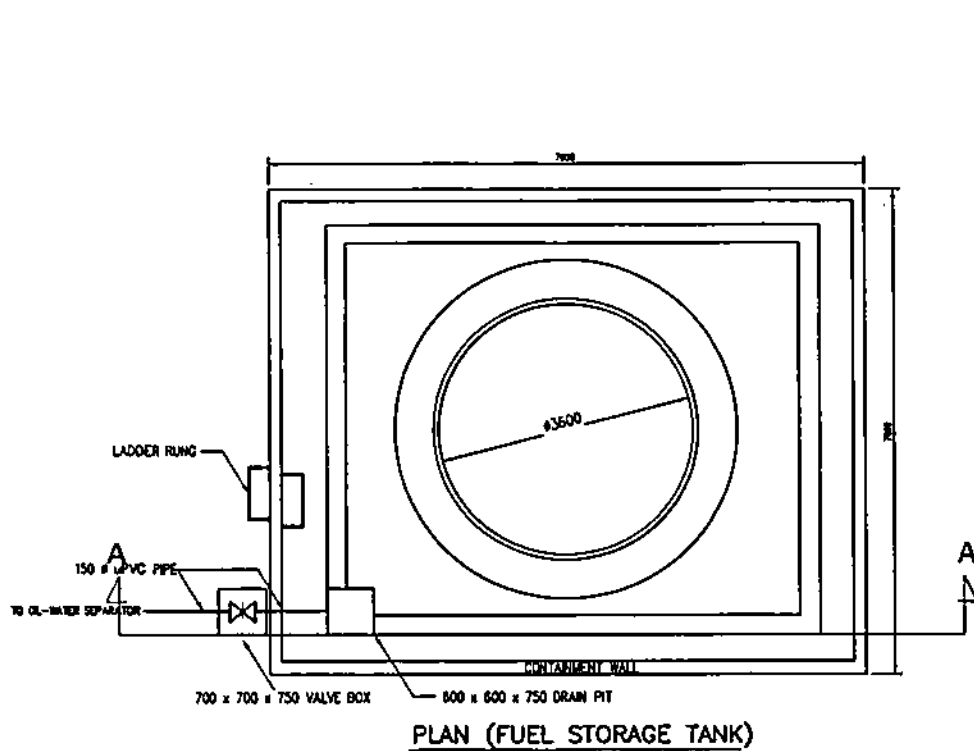

LEGEND :

- BUTTERFLY VALVE W/ BOX
- GATE VALVE (NORMALLY CLOSED)
- GATE VALVE (NORMALLY OPENED)

NOTES:

1. ALL DIMENSIONS ARE IN MILLIMETERS UNLESS OTHERWISE SPECIFIED.
2. REFER TO CIVIL DRAWINGS FOR THE DETAILS OF TANK FOUNDATION, CONTAINMENT WALL, DRAIN PIT/DITCH AND CONTAINMENT ACCESS LADDER.
3. VERTICAL LADDER OF EACH TANK SHALL BE PROVIDED WITH SAFETY CAGE AS SHOWN ON DETAILED DRAWINGS.
4. REFER TO DRAWINGS NOS. PKG160-BDM-17.001 TO .008 FOR DETAILS OF TANK APPURTENANCES.

OWNER				NATIONAL POWER CORPORATION AGHAM ROAD, DILIMAN, QUEZON CITY	
PROJECT: SUPPLY, DELIVERY, INSTALLATION AND TEST OF 1425 KL AND 2208 KL FOST FOR PATANANGAN DPP, PALANAN DPP, AND JOMALIG DPP INCLUDING CONSTRUCTION OF ASSOCIATED FACILITIES UNDER PACKAGE 1					
LOCATION: JOMALIG, QUEZON					
TITLE <b>PLAN AND SECTION</b> 1X60 KL FOST JOMALIG DPP					
DESIGNED	BY	CHKD	DATE	SUBMITTED	R. N. CALAWAN
DRAWN	MAN			RECOMMENDED	A. N. RODRIGUEZ
REVIEWED	PRICILA ENGR. / MCHT.			APPROVED	G. S. MAGPOC JR.
CHECKED					
ELEC					
LEAD	JTC				
DWS No. JomDPP-2DM-17.003		SPEC. NO. LuzP20211795			
SCALE: AS SHOWN			SID DRAWING		

REV.	DATE	NATURE OF REVISION	BY	CHKD.	RECD.	APPD.



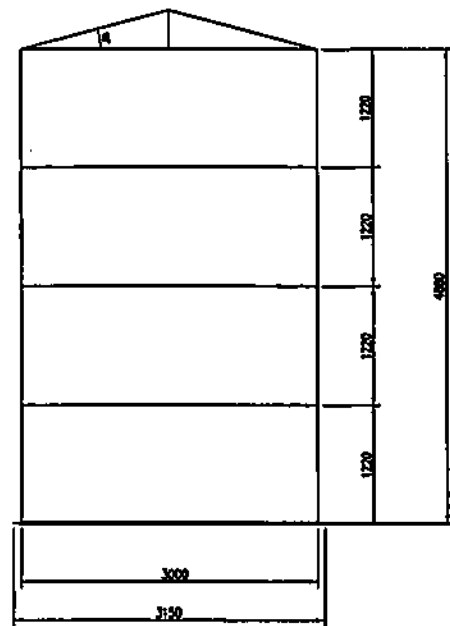

SIDE ELEVATION

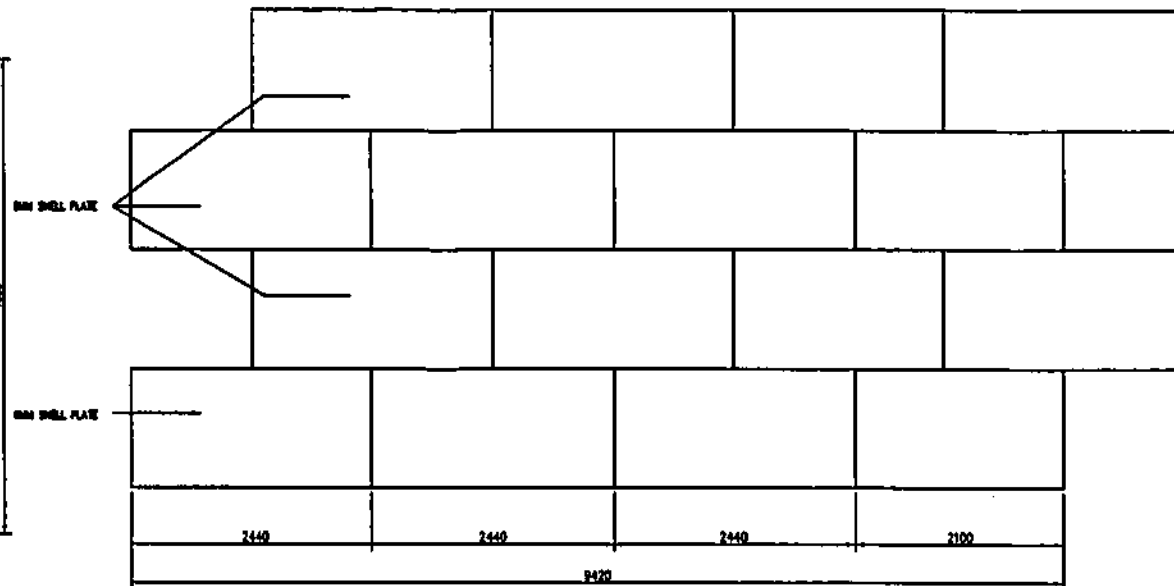

SHELL PLATE ARRANGEMENT

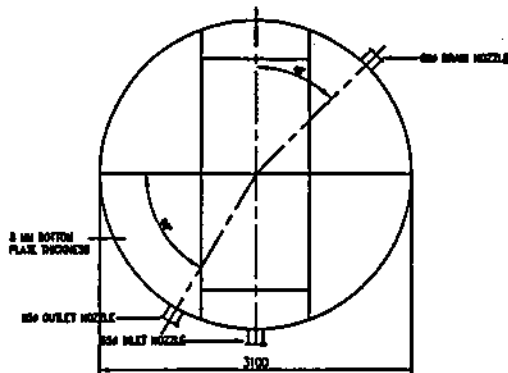

BOTTOM PLATE ARRANGEMENT

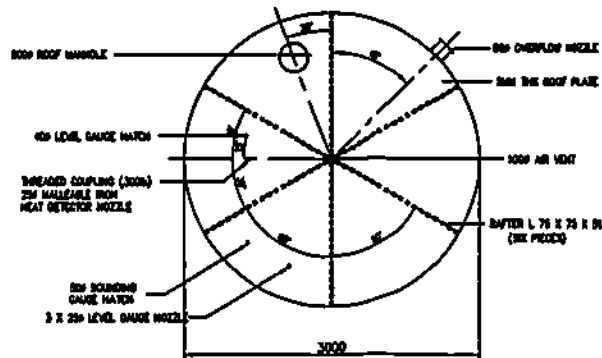

ROOF PLATE ARRANGEMENT

NOTES:

1. ALL DIMENSIONS ARE IN MILLIMETERS UNLESS OTHERWISE SPECIFIED.
2. THE FUEL OIL STORAGE TANK SHALL BE CONSTRUCTED TO CONFORM WITH THE LATEST EDITION OF THE APPLICABLE STANDARDS AND THE MINIMUM REQUIREMENTS SHOWN ON THIS DRAWING AND AS SPECIFIED IN THE TECHNICAL SPECIFICATIONS.
3. DETAILED DRAWINGS IF NECESSARY SHALL BE SUBMITTED BY THE CONTRACTOR FOR MPC REVIEW AND APPROVAL.
4. NOZZLES FOR HEAT DETECTOR AND FOAM NOZZLE SHALL BE SUPPLIED WITH TREADED CAP AND BLIND FLANGE, RESPECTIVELY.
5. ALL WELDING WORKS SHALL CONFORM TO THE REQUIREMENTS OF THE SPECIFICATION AND API 650.
6. FLANGED REDUCER (80 # X 65#) SHALL BE PROVIDED EACH AT OUTLET, INLET AND FOAM NOZZLES.
7. TANK NOZZLES, CAGED LADDER, MANHOLE, ETC. SHALL BE INSTALLED BASED ON TANK ORIENTATION SHOWN ON RESPECTIVE PLANTS LAYOUT.

OWNER:		 <b>NATIONAL POWER CORPORATION</b> AGHAM ROAD, DILIMAN, QUEZON CITY	
PROJECT: SUPPLY, DELIVERY, INSTALLATION AND TEST OF 1226 KL AND 2000 KL FOST FOR PATRAMUNGAN DFP, PALAMAN DFP, AND JOMALIS DFP INCLUDING CONSTRUCTION OF ASSOCIATED FACILITIES UNDER PACKAGE 1			
LOCATION: PATRAMUNGAN, QUEZON			
TITLE:		<b>PLATE ARRANGEMENT AND DETAILS</b>	
		<b>35 KL FUEL OIL STORAGE TANK</b>	
DESIGNED	BY	CHKD	DATE
DRAWN	MAN		
REVIEWED	PRINCIPAL ENGR./ARCHT.		RECOMMENDED:
EMPL/MENT			A.M. RODRIGUEZ
ELEC.			APPROVED:
MECH.	J.C.		G. S. MAGPOC JR. DEPT. MANAGER - E&C

DRG. NO. PKG135-CDM-17.001 | SPEC. NO. LUCP20211793e

REV.	DATE	NATURE OF REVISION	BY	CHKD	REV.	APPD	SCALE: AS SHOWN	<b>3/D DRAWING</b>	S.A. 0
------	------	--------------------	----	------	------	------	-----------------	--------------------	--------

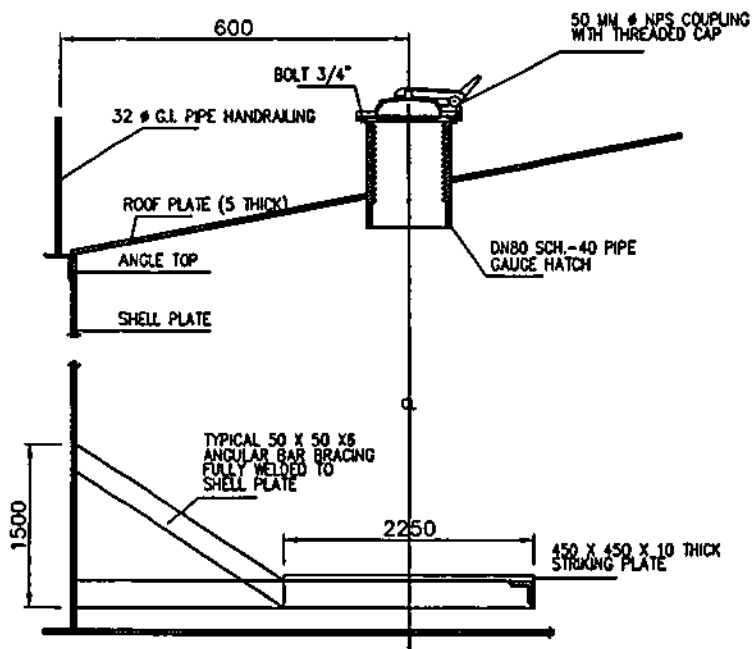

Gauge Hatch Nozzle and Striking Plate

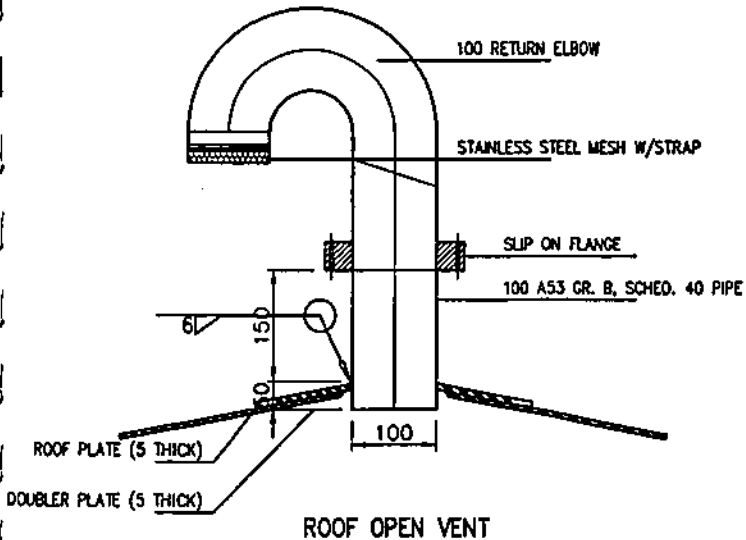

Roof Open Vent

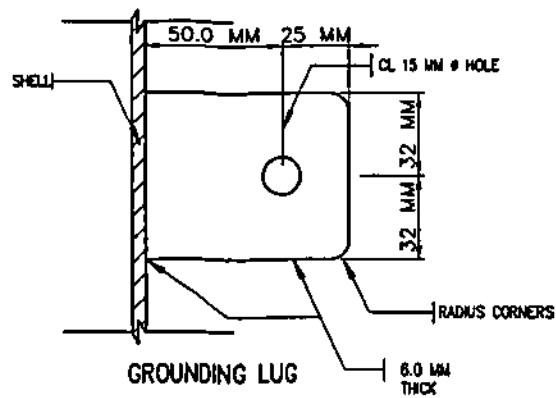

Grounding Lug

NOTES FOR GROUNDING LUG:

- LUG MATERIAL SHALL BE AUSTENITIC STAINLESS STEEL WHEN ATTACHED TO CARBON OR LOW ALLOY STEEL PARTS.
- TWO SETS INCLUDING 3 M LENGTH, 20 MM # COPPER GROUNDING ROD ARE REQUIRED.

VARIES (NEAR THE CENTER OF TANK)

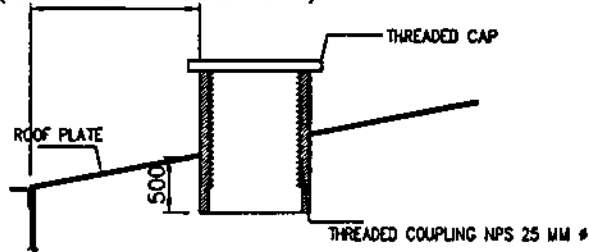



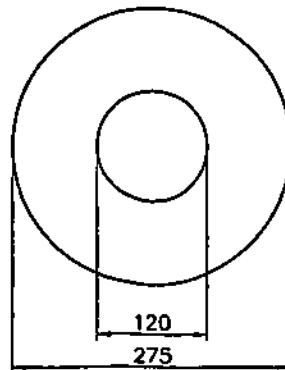

Heat Detector Nozzle



Stiffener Plate for 100 mm Vent Nozzle

NOTES :

- ALL DIMENSIONS ARE IN MILLIMETERS UNLESS OTHERWISE SPECIFIED.
- THE FUEL OIL STORAGE TANK SHALL BE DESIGNED AND CONSTRUCTED TO CONFORM WITH THE REQUIREMENTS OF THE LATEST EDITION OF API 650 AND THE MINIMUM REQUIREMENTS SHOWN ON THIS DRAWING OR AS SPECIFIED IN THE TECHNICAL SPECIFICATIONS.
- DETAILED DRAWINGS AS REQUIRED SHALL BE SUBMITTED BY THE CONTRACTOR FOR NPC REVIEW/APPROVAL.
- NOZZLES FOR HEAT DETECTOR AND FOAM NOZZLE SHALL BE SUPPLIED WITH THREADED CAP AND BLIND FLANGE, RESPECTIVELY.
- ALL WELDING WORKS SHALL CONFORM TO THE REQUIREMENTS OF THE SPECIFICATION AND API 650.

OWNER		 <b>NATIONAL POWER CORPORATION</b> AGHAM ROAD, DILIMAN, QUEZON CITY	
PROJECT: SUPPLY, DELIVERY, INSTALLATION AND TEST OF 1436 KL AND 2266 KL FUEL OIL STORAGE TANKS, PALAMAN OPP AND JOMALIG OPP INCLUDING CONSTRUCTION OF ASSOCIATED FACILITIES UNDER PACKAGE 1			
LOCATION: MINDANAWA, QUEZON PROVINCE			
TITLE: <b>NOZZLE ARRANGEMENT AND OTHER DETAILS</b> 35 KL FUEL OIL STORAGE TANK			
DESIGNED	BY	CHKD	DATE
DRAWN	197		
REVIEWED	PRINCIPAL ENGR. / ARCHT.	RECOMMENDED	
CIVIL/ARCHT.		APPROVED	
ELEC.			
MECH.			
SUBMITTED		 <b>R. N. F. SAWAYAN</b> Engr.	
REVIEWED		 <b>A. N. RODRIGUEZ</b> Engr.	
APPROVED		 <b>G. B. MAGPOC, JR.</b> Dept. Manager, O&O	
DWG. NO. PKG135-BDM-17.002		SPEC. NO. LuzP20Z11793a	

REV.	DATE	DESCRIPTION	BY	CHKD	REVL	APP.	SCALE: AS SHOWN	<b>3/D DRAWING</b>	PAGE 5
------	------	-------------	----	------	------	------	-----------------	--------------------	--------

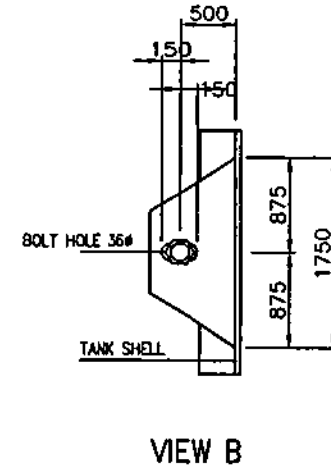
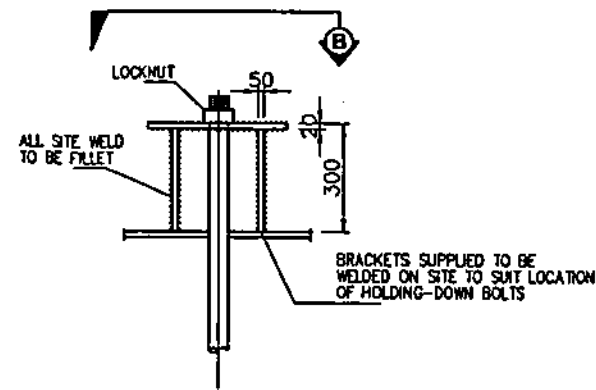
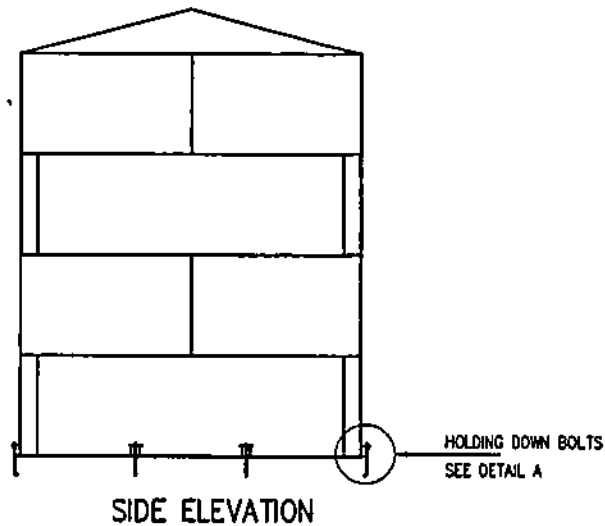



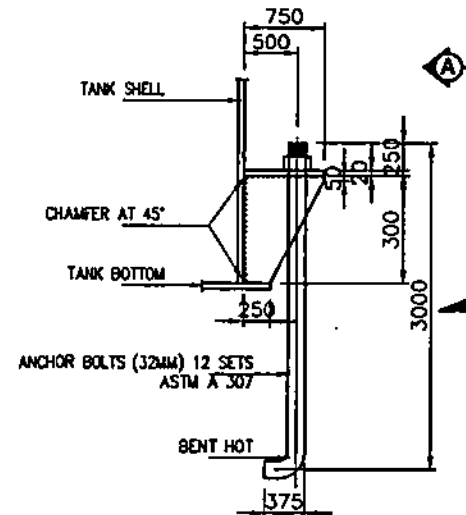
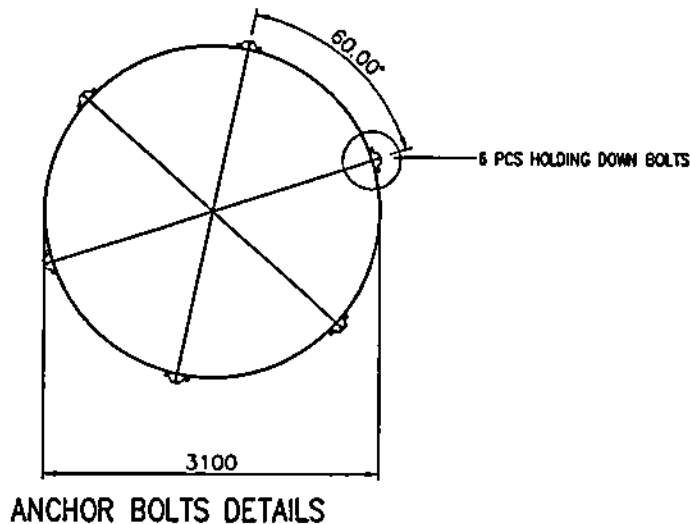

HOLDING DOWN BOLTS DETAILS



NOTES :

1. ALL DIMENSIONS ARE IN MILLIMETERS UNLESS OTHERWISE SPECIFIED.
2. THE FUEL OIL STORAGE TANK SHALL BE CONSTRUCTED TO CONFORM WITH THE LATEST EDITION OF API 650 AND THE MINIMUM REQUIREMENTS SHOWN ON THIS DRAWING OR AS SPECIFIED IN THE TECHNICAL SPECIFICATIONS.
3. DETAILED DRAWINGS, IF NECESSARY SHALL BE SUBMITTED BY THE CONTRACTOR FOR NPC REVIEW/ APPROVAL.
4. ALL WELDING WORKS SHALL CONFORM TO THE REQUIREMENTS OF THE SPECIFICATION AND API 650.
5. REFER TO RELEVANT CIVIL DRAWINGS FOR DETAILS OF FOUNDATION DRAWINGS.

OWNER:		 <b>NATIONAL POWER CORPORATION</b> AGHAM ROAD, DILMÁN, QUEZÓN CITY	
PROJECT: SUPPLY, DELIVERY, INSTALLATION AND TEST OF 1206 M. AND 2300 M. FOST FOR PATNABUNGAN DPP, PALANAN DPP AND JOMALIS DPP INCLUDING CONSTRUCTION OF ASSOCIATED FACILITIES UNDER PACKAGE 1			
LOCATION: PATNABUNGAN, QUEZÓN PROVINCE			
TITLE:		<b>HOLDING DOWN BOLT DETAILS</b> <b>35 KL FUEL OIL STORAGE TANK</b>	
DESIGNED	BY	CHKD	DATE
DRAWN			
REVIEWED	PRINCIPAL ENGR./ ARCHT.		
CHECKED			
ELEC.			
MECH.			
SUBMITTED:		 <b>R. M. CADSAWAN</b>	
RECOMMENDED:		 <b>A. N. RODRIGUEZ</b>	
APPROVED:		 <b>G. E. MAGPOC, JR.</b> <small>Engr. Member, PRC</small>	

DWG NO. **PKG135-EDM-17.003** SPEC. NO. **LUZP2021130Su**

REV.	DATE	NATURE OF REVISION	BY	CHKD.	RECD.	APPD.

SCALE: AS SHOWN

**BID DRAWING**      REV: 3

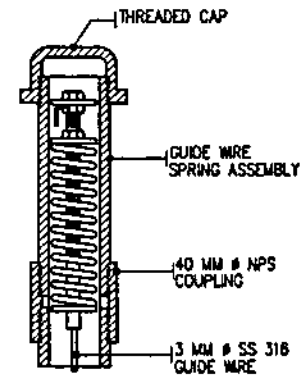

DETAIL 'C'  
SCALE NTS

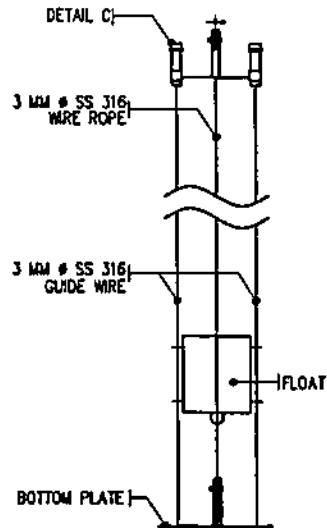

FRONT VIEW

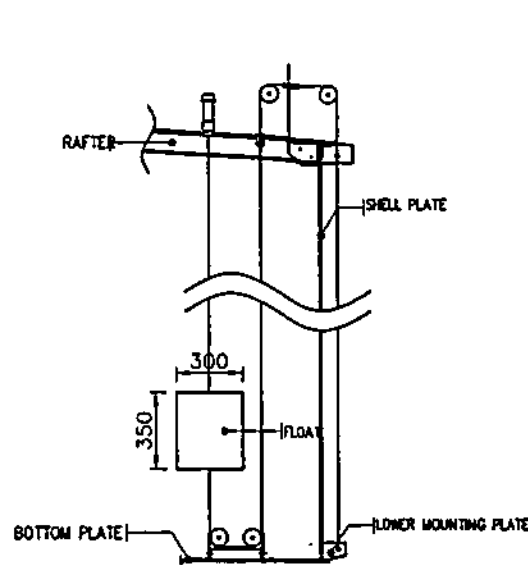

SECTIONAL VIEW

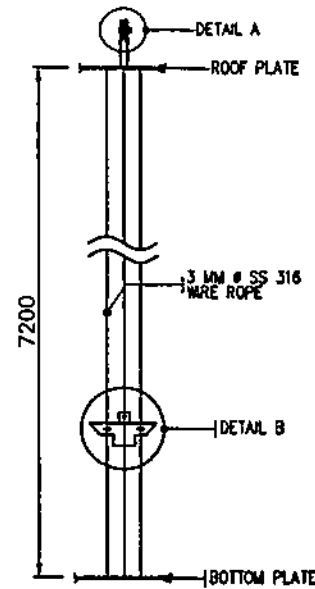

EXTERNAL VIEW

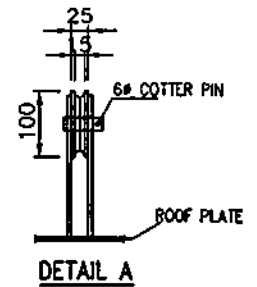

DETAIL A

NOTES :

1. ALL DIMENSIONS ARE IN MILLIMETERS UNLESS OTHERWISE SPECIFIED.
2. THE FUEL OIL STORAGE TANK SHALL BE CONSTRUCTED TO CONFORM WITH THE LATEST EDITION OF API 650 AND THE MINIMUM REQUIREMENTS SHOWN IN THIS DRAWING OR AS SPECIFIED IN THE TECHNICAL SPECIFICATIONS.
3. DETAILED DRAWINGS, IF NECESSARY SHALL BE SUBMITTED BY THE CONTRACTOR FOR NPC REVIEW/APPROVAL.
4. ALL WELDING WORKS SHALL CONFORM TO THE REQUIREMENTS OF THE SPECIFICATION AND API 650.
5. CALIBRATION SCALES SHALL BE PAINTED ON THE TANK AND SHALL BE LARGE ENOUGH SO IT CAN EASILY BE VISIBLE FROM THE CONTROL ROOM / POWERHOUSE
6. SIZE AND DIMENSIONS OF FLOAT AND BOARD TANK GAUGE ASSEMBLY MAY BE MODIFIED IN COORDINATION WITH THE DEVICE SUPPLIER.

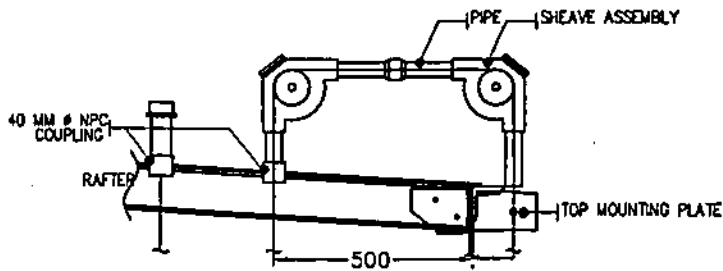

UPPER ROLLER ASSEMBLY  
SCALE NTS

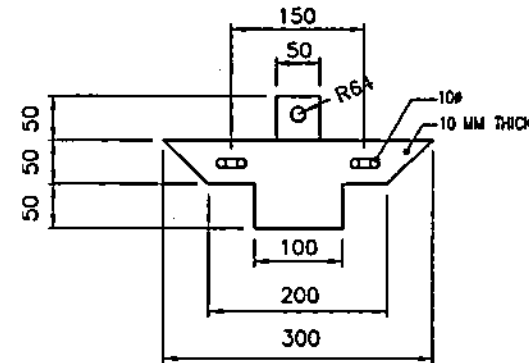

DETAIL B  
SCALE NTS

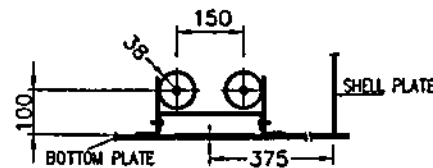

LOWER ROLLER ASSEMBLY  
SCALE NTS

OWNER:		 <b>NATIONAL POWER CORPORATION</b> AGHAM ROAD, DILIMAN, QUEZON CITY	
PROJECT: SUPPLY, DELIVERY, INSTALLATION AND TEST OF 1325 KL AND 2200 KL FOOT FOR PATANUNGAN DPP, PALAMAN DPP AND JOMALIG DPP INCLUDING CONSTRUCTION OF ASSOCIATED FACILITIES UNDER PACKAGE 1			
LOCATION: PATANUNGAN, QUEZON PROVINCE			
TITLE:		<b>LEVEL GAUGE INDICATOR DETAILS</b> <b>35 KL FUEL OIL STORAGE TANK</b>	
DESIGNED	BY	CHKD	DATE
DRAWN			
REVIEWED	PRINCIPAL ENGR./ARCHT.	RECOMMENDED	
CIVIL/ARCHT			
ELEC		APPROVED:	
MECH			
DWG NO. PKG135-BDM-17.004		SPEC NO. LUZP20211793-1	
SCALE: AS SHOWN	BID DRAWING		REV. 0

REV.	DATE	NATURE OF REVISION	BY	CHKD	RECD	APPD

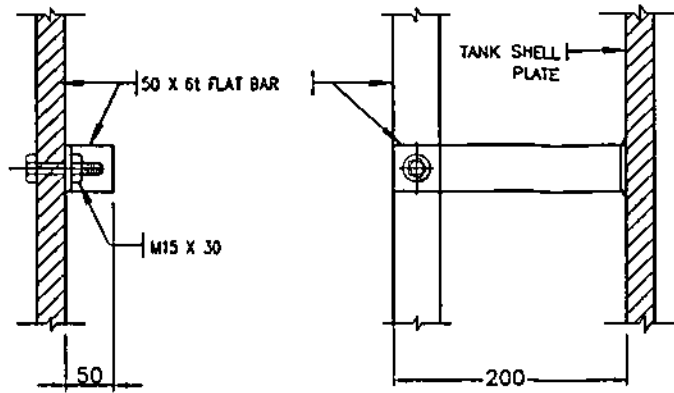
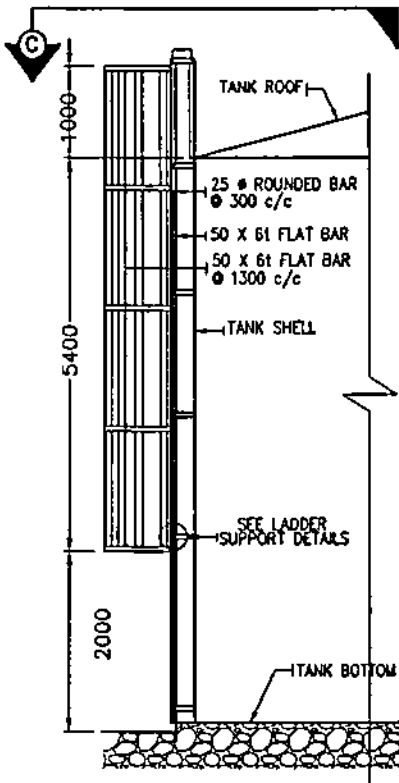

FRONT SIDE

LADDER SUPPORT DETAILS

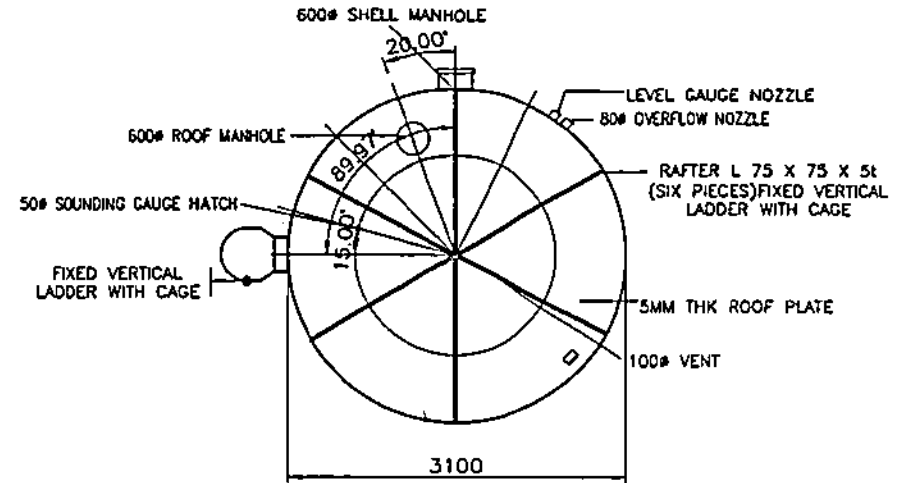

TANK ORIENTATION

NOTES :

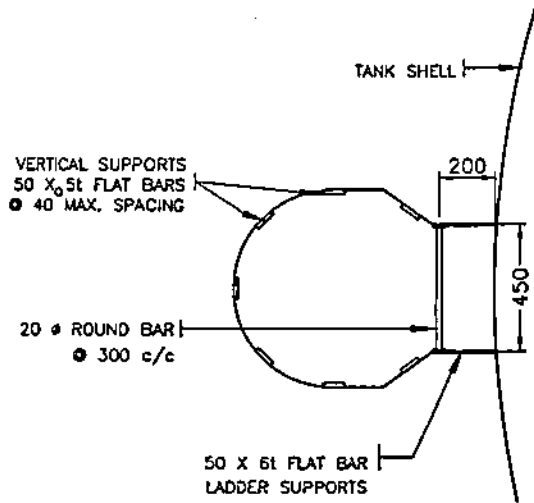

1. ALL DIMENSIONS ARE IN MILLIMETERS UNLESS OTHERWISE SPECIFIED.
2. THE FUEL OIL STORAGE TANK SHALL BE CONSTRUCTED TO CONFORM WITH THE LATEST EDITION OF API 650 AND THE MINIMUM REQUIREMENTS SHOWN ON THIS DRAWING OR AS SPECIFIED IN THE TECHNICAL SPECIFICATIONS.
3. DETAILED DRAWINGS SHALL BE SUBMITTED BY THE SUPPLIER/CONTRACTOR FOR NPC REVIEW/APPROVAL.
4. NOZZLE SIZES FOR HEAT DETECTOR, FOAM NOZZLE AND LEVEL GAUGE HATCH SHALL BE SUPPLIED WITH PLUGS/BLIND FLANGES.
5. ALL WELDING WORKS SHALL CONFORM TO THE REQUIREMENTS OF THE SPECIFICATION AND API 650.
6. NOZZLE FOR TANK SHALL BE INSTALLED BASED ON TANK ORIENTATION SHOWN ON PLANT'S LAYOUT.

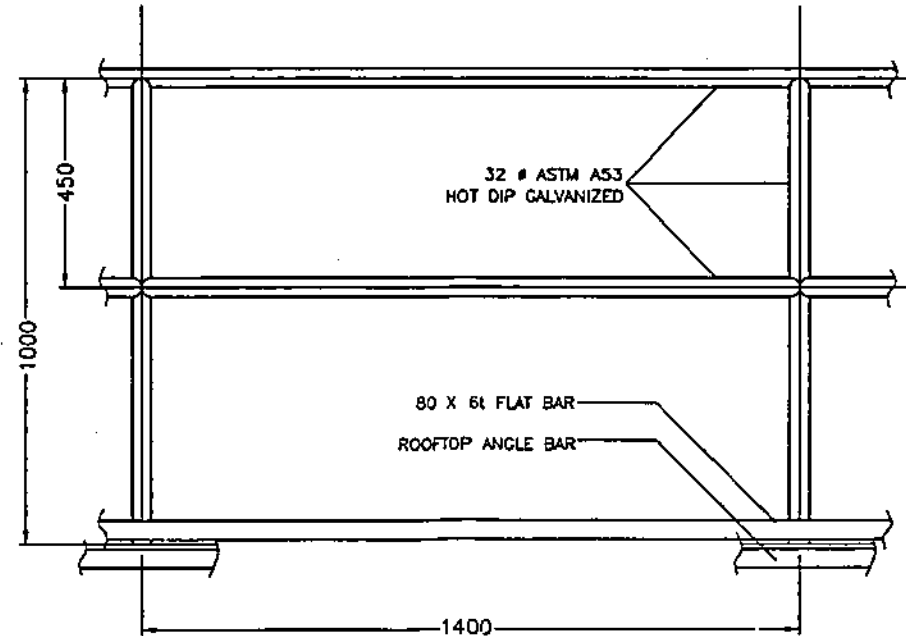

SECTION C

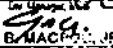

TYPICAL ROOF HANDRAIL

OWNER:		 <b>NATIONAL POWER CORPORATION</b> AGHAM ROAD, DILIMAN, QUEZON CITY	
PROJECT: SUPPLY, DELIVERY, INSTALLATION AND TEST OF 1X35 KL AND 2X10 KL FOOT FOR PATANAKANG DFP, PALANAN DFP AND JOMALUG DFP INCLUDING CONSTRUCTION OF ASSOCIATED FACILITIES UNDER PACKAGE 1 LOCATION: PATANAKANG, QUEZON PROVINCE			
TITLE: <b>TANK STAIR AND RAILING DETAILS</b> 35 KL FUEL OIL STORAGE TANK			
DESIGNED	BY	CHKD	DATE
DRAWN	BY	CHKD	DATE
REVIEWED	BY	CHKD	DATE
APPROVED	BY	CHKD	DATE
E.I.C.	BY	CHKD	DATE
LEAD	BY	CHKD	DATE
SUBMITTED:		 R. M. CADANGAN	
RECORDED:		 A. N. RODRIGUEZ	
APPROVED:		 G. B. MACAPUN JR.	

NO. REV.	DATE	REASON FOR REVISION	BY	CHKD	APPROV.	SCALE	AS SHOWN	DATE	BY	CHKD	APPROV.

BID DRAWING

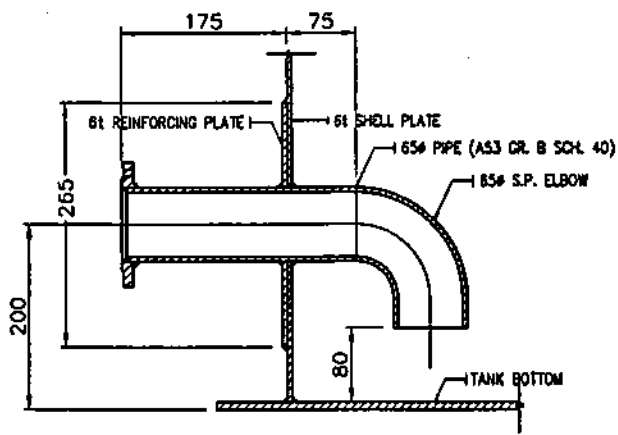

OUTLET NOZZLE

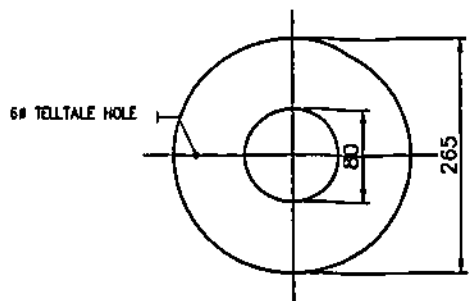

REINFORCING PLATE FOR 65# NOZZLE

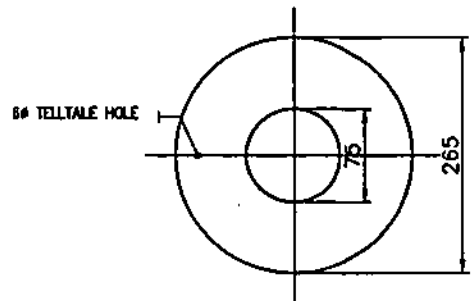

REINFORCING PLATE FOR 50# NOZZLE

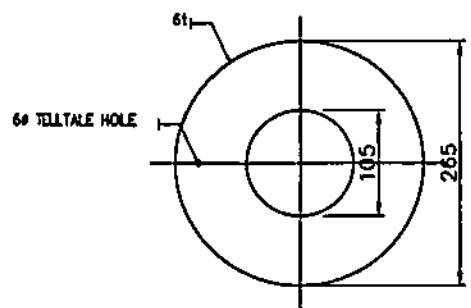

REINFORCING PLATE FOR 80# NOZZLE

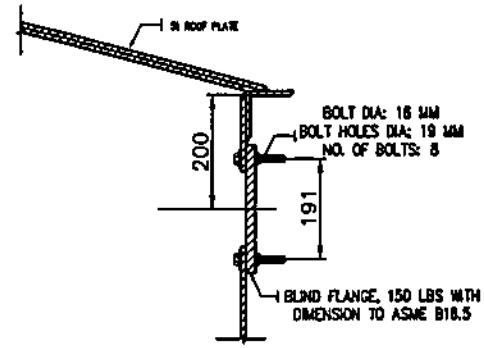

FOAM CHAMBER OPENING

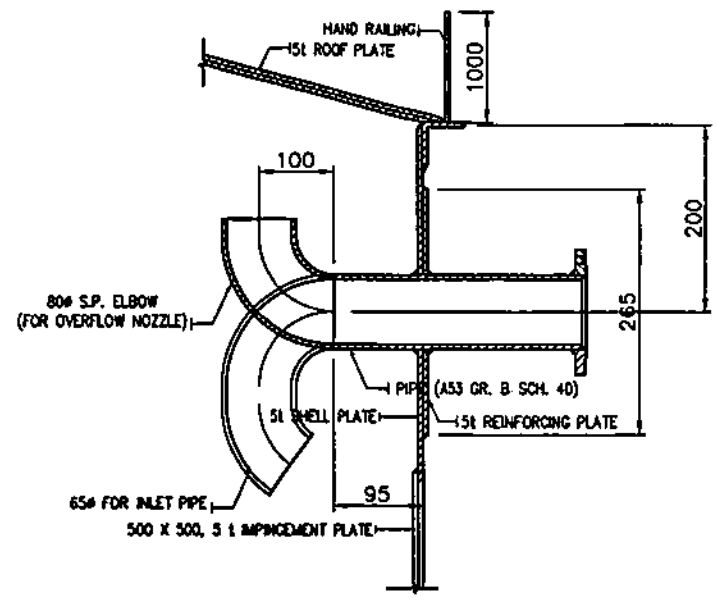

INLET/OVERFLOW NOZZLES (TYPICAL)

NOTES :

1. ALL DIMENSIONS ARE IN MILLIMETERS UNLESS OTHERWISE SPECIFIED.
2. THE FUEL OIL STORAGE TANK SHALL BE CONSTRUCTED TO CONFORM WITH THE LATEST EDITION OF API 650 AND THE MINIMUM REQUIREMENTS SHOWN ON THIS DRAWING OR AS SPECIFIED IN THE TECHNICAL SPECIFICATIONS.
3. DETAILED DRAWINGS, IF NECESSARY SHALL BE SUBMITTED BY THE CONTRACTOR FOR MPC REVIEW/APPROVAL.
4. ALL WELDING WORKS SHALL CONFORM TO THE REQUIREMENTS OF THE SPECIFICATION AND API 650.
5. INLET AND OVERFLOW NOZZLES SHALL BE SEPARATELY LOCATED DEPENDING ON THE ORIENTATION OF THE TANK SHOWN ON RESPECTIVE PLANT'S LAYOUT.
6. THE DRAINAGE PROCEDURE FOR DRAIN OFF NOZZLE SHALL INCLUDE THE FOLLOWING STEP FOR API 650:
  - A. A HOLE SHALL BE CUT IN THE BOTTOM PLATE OR A SUMP SHALL BE PLACED IN THE FOUNDATION BEFORE BOTTOM PLACEMENT;
  - B. A HEAVY EXCAVATION SHALL BE MADE TO CONFORM TO THE SHAPE OF THE DRAIN OFF SUMP. THE SUMP SHALL BE BUILT IN PLACE, AND THE FOUNDATION SHALL BE COMPACTED AROUND THE SUMP AFTER PLACEMENT; AND
  - C. THE SUMP SHALL BE WELDED TO THE BOTTOM.

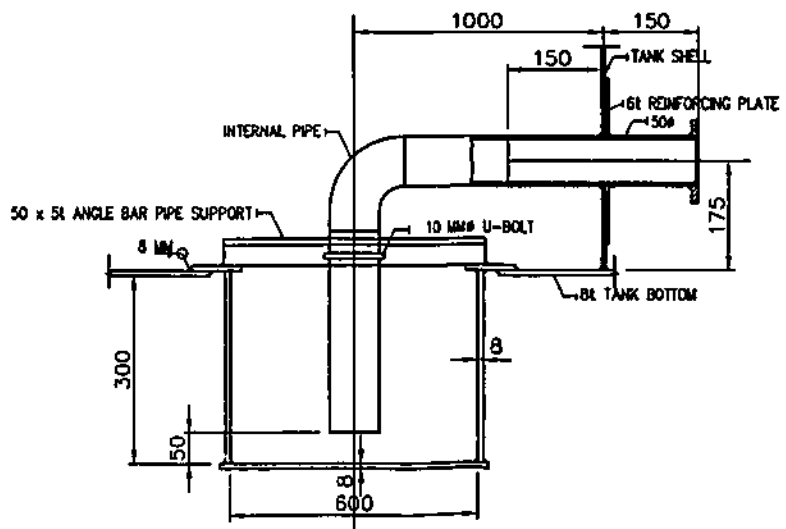

WATER DRAW-OFF SUMP

OWNER:		 <b>NATIONAL POWER CORPORATION</b> AGHAM ROAD, DILIMAN, QUEZON CITY	
PROJECT: SUPPLY, DELIVERY, INSTALLATION AND TEST OF 1200 KL AND 2000 KL POTS FOR PATAMUNGAN DPT, PALAMAN DPT AND JOMALIG DPT INCLUDING CONSTRUCTION OF ASSOCIATED FACILITIES UNDER PACKAGE 1			
LOCATION: PATAMUNGAN, QUEZON PROVINCE			
TITLE:		<b>NOZZLE DETAILS</b> <b>35 KL FUEL OIL STORAGE TANK</b>	
DESIGNED BY	CHKD	DATE	SUBMITTED
DRAWN			R. M. GABSAWAN
REVIEWED	PRINCIPAL ENGINEER/ARCHT.		RECOMMENDED
CIVIL/ARCHT			A. N. RODRIGUEZ
ELEC.			APPROVED
MCC			G. B. MACAPUN

DWG NO. PKG135-BDM-17.006 SPEC NO. LuzP202117006

REV.	DATE	REVISION	BY	CHKD	RECD	APPL

EID DRAWING

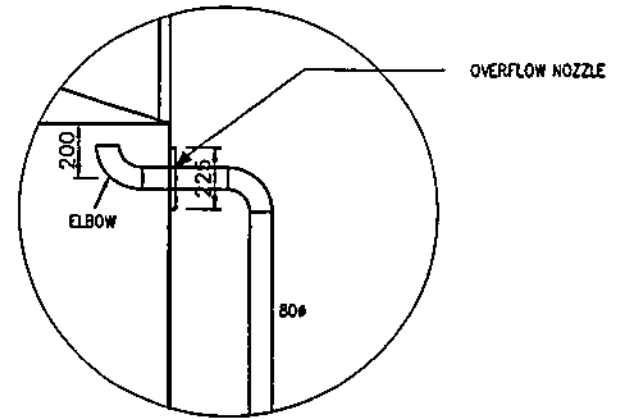
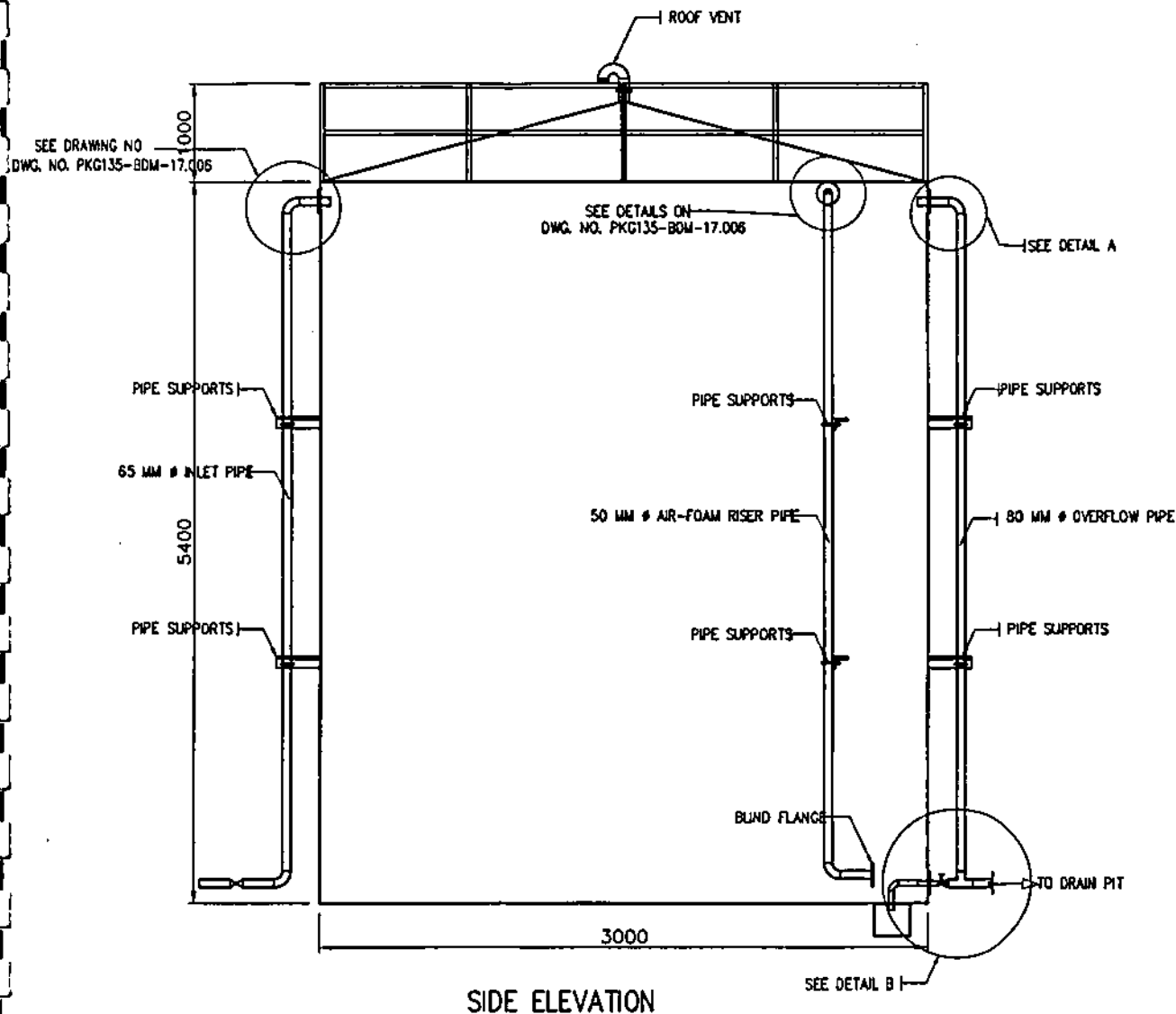

DETAIL A

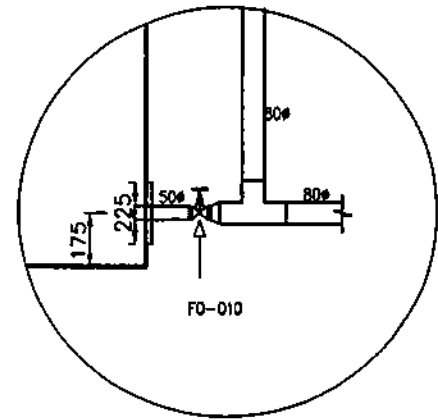

DETAIL B

SIDE ELEVATION

NOTES :

1. ALL DIMENSIONS ARE IN MILLIMETERS UNLESS OTHERWISE SPECIFIED.
2. THE FUEL OIL STORAGE TANK SHALL BE CONSTRUCTED TO CONFORM WITH THE LATEST EDITION OF API 650 AND THE MINIMUM REQUIREMENTS SHOWN ON THIS DRAWING OR AS SPECIFIED IN THE TECHNICAL SPECIFICATIONS.
3. DETAILED DRAWINGS, IF NECESSARY SHALL BE SUBMITTED BY THE CONTRACTOR FOR NPC REVIEW/APPROVAL.
4. ALL WELDING WORKS SHALL CONFORM TO THE REQUIREMENTS OF THE SPECIFICATION AND API 650.
5. PIPE SHALL CONFORM TO ASTM A. 53 GR. B, SCHEDULE 40 AND SEAMLESS PIPE

OWNER:		<b>NATIONAL POWER CORPORATION</b> AGHAM ROAD, DILIMAN, QUEZON CITY	
PROJECT: SUPPLY, DELIVERY, INSTALLATION AND TEST OF 1338 KL AND 2398 KL FOST FOR PATNANUNGAN DPP, PALAHAN DPP AND JOMALIN DPP INCLUDING CONSTRUCTION OF ASSOCIATED FACILITIES UNDER PACKAGE 1			
LOCATION: PATNANUNGAN, QUEZON PROVINCE			
TITLE:		<b>TANK NOZZLE AND PIPINGS</b> <b>35 KL FUEL OIL STORAGE TANK</b>	
DESIGNED	BY	CHKD	DATE
DRAWN	BY		
REVIEWED	PRINCIPAL ENGR./ARCHT.		RECOMMENDED
CHALNANT			
ELSC.			APPROVED
MECH.	JS	MF	
DWG. NO. PKG135-BDM-17.007		SPEC. NO. LuzP20211793e	
SCALE: AS SHOWN		EID DRAWING	

REV.	DATE	NATURE OF REVISION	BY	CHKD	RECD	APPR.

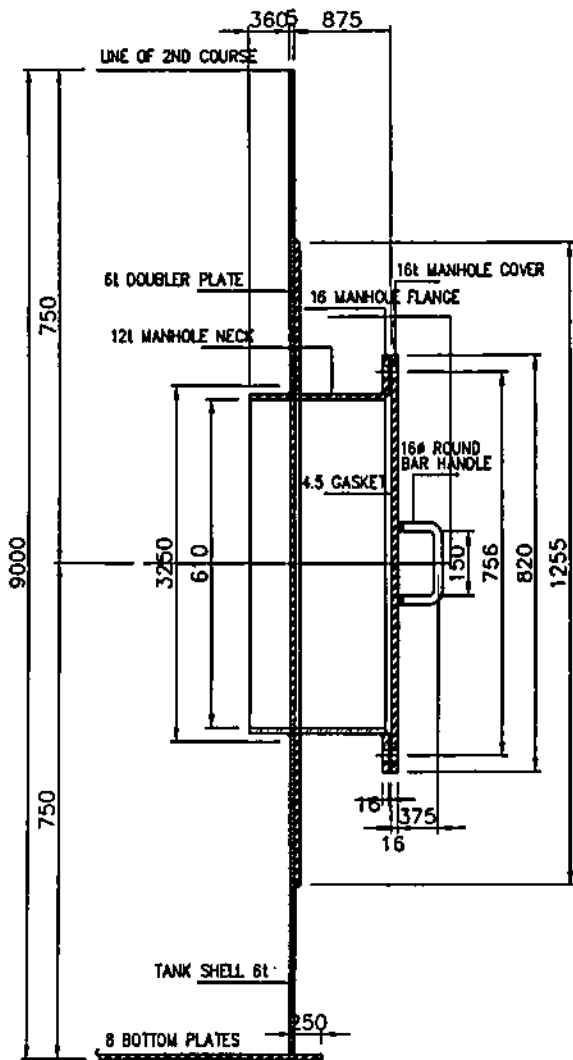

SHELL MANHOLE SECTION

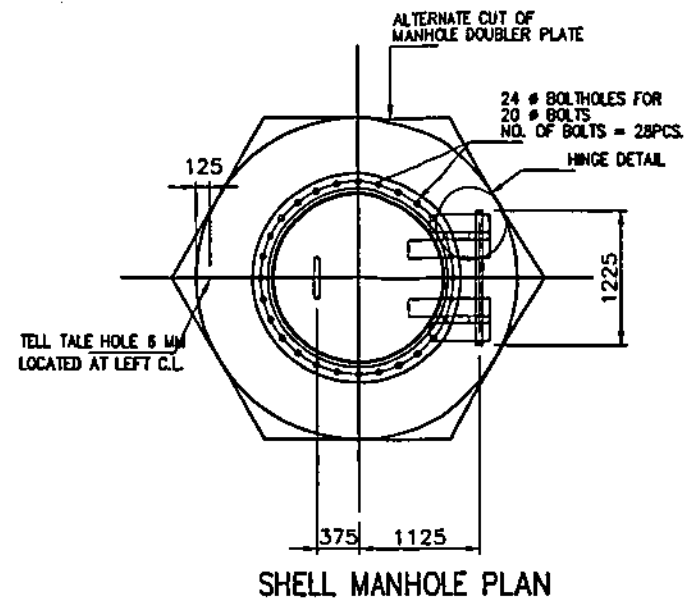

SHELL MANHOLE PLAN

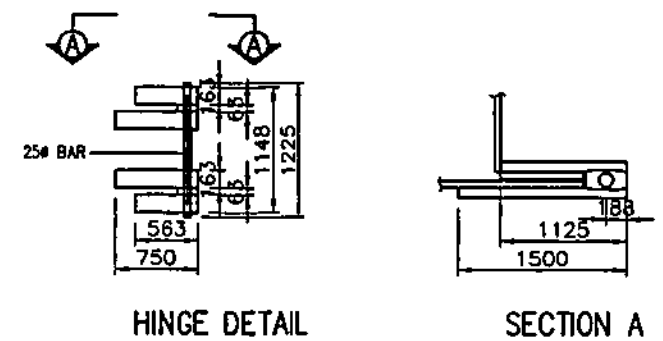

HINGE DETAIL

SECTION A

NOTES :

1. ALL DIMENSIONS ARE IN MILLIMETERS UNLESS OTHERWISE SPECIFIED.
2. THE FUEL OIL STORAGE TANK SHALL BE CONSTRUCTED TO CONFORM WITH THE LATEST EDITION OF API 650 AND THE MINIMUM REQUIREMENTS SHOWN ON THIS DRAWING OR AS SPECIFIED IN THE TECHNICAL SPECIFICATIONS.
3. DETAILED DRAWINGS, IF NECESSARY SHALL BE SUBMITTED BY THE CONTRACTOR FOR NPC REVIEW/APPROVAL.
4. THE CONTRACTOR MAY PROPOSE DIFFERENT MANHOLE HINGE DETAIL SUBJECT TO NPC'S APPROVAL.
5. ALL WELDING WORKS SHALL CONFORM TO THE REQUIREMENTS OF THE SPECIFICATION AND API 650.

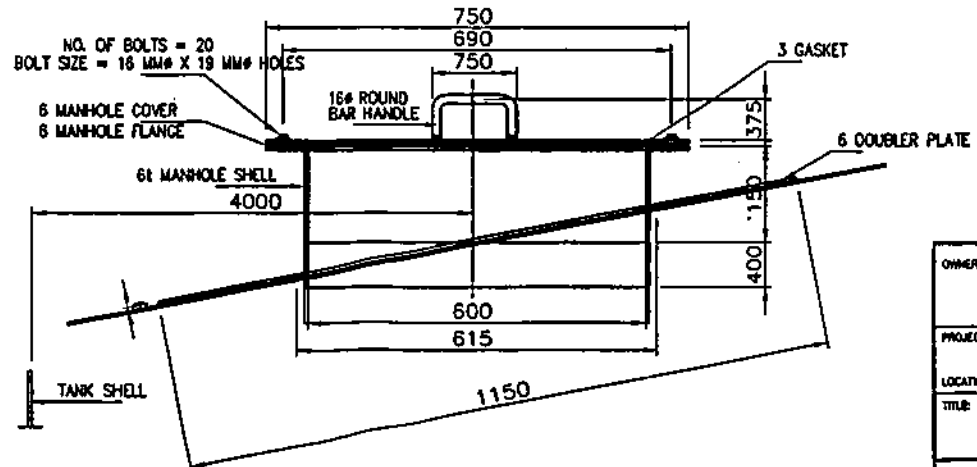

ROOF MANHOLE SECTION

OWNER		 <b>NATIONAL POWER CORPORATION</b> AGHAM ROAD, DILIMAN, QUEZON CITY	
PROJECT: SUPPLY, DELIVERY, INSTALLATION AND TEST OF 1X38 HL AND 2X38 HL FOOT FOR PATANUNGAN DPP, PALAMAN DPP AND JOMALIG DPP INCLUDING CONSTRUCTION OF ASSOCIATED FACILITIES UNDER PACKAGE 1 LOCATION: PATANUNGAN, QUEZON PROVINCE			
TITLE: <b>ROOF AND SHELL MANHOLE DETAILS</b> <b>35 KL FUEL OIL STORAGE TANK</b>			
DESIGNED	BY	CHKD	DATE
DRAWN	BY	CHKD	DATE
REVIEWED	PRINCIPAL ENGR./ARCHT.	RECOMMENDED	
CIVIL/ARCHT		APPROVED	
E.L.C.			
MECH			
DWG. NO. PRC-108-BDM-17.008		SPEC. NO. LuzP202417-003	
REV. DATE		BY	
REVISION		CHKD	
		RECA	
		TAG	
		SIGNED: AD-S-201	
<b>BID DRAWING</b>			



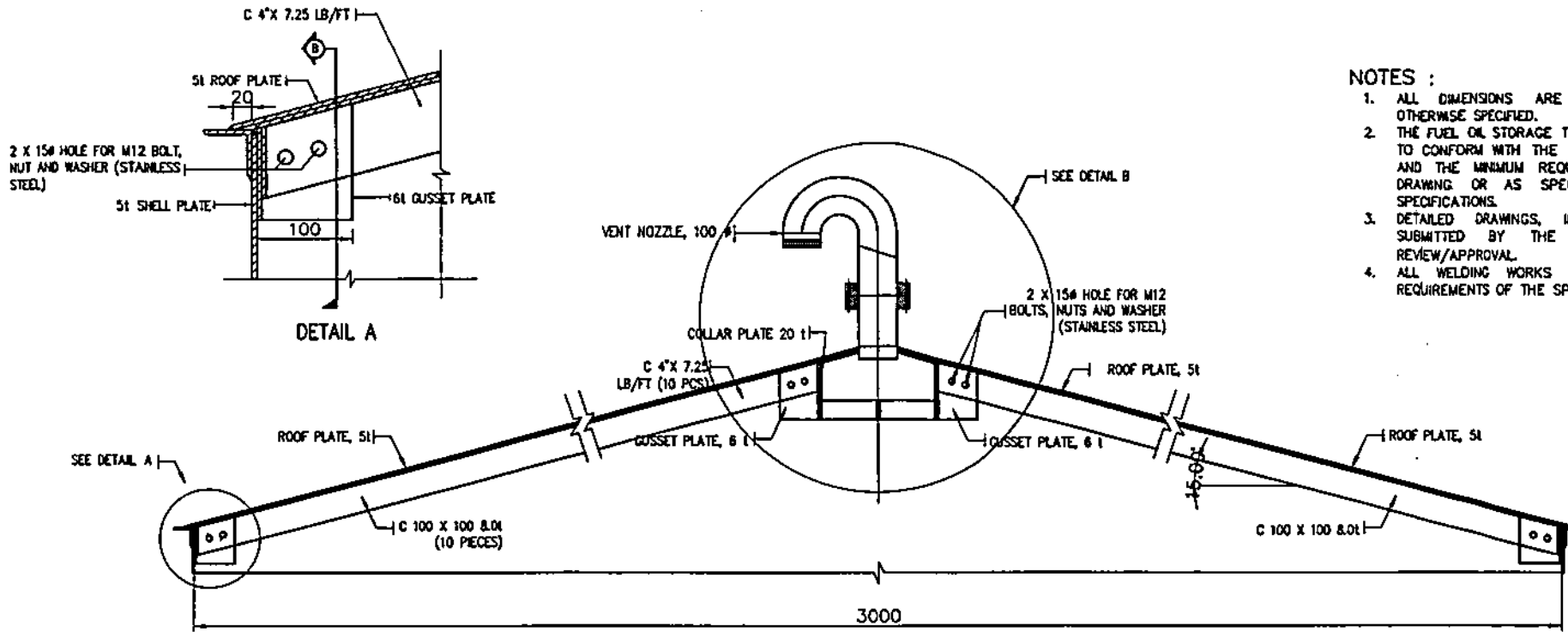

RAFTER DETAILS

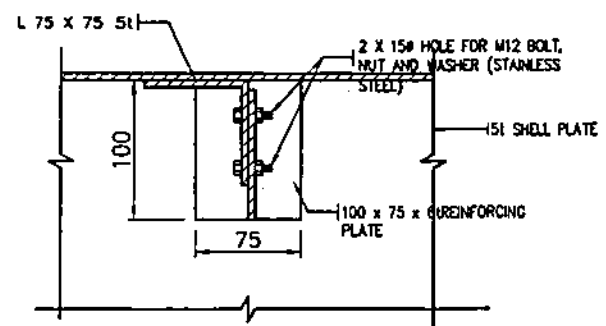



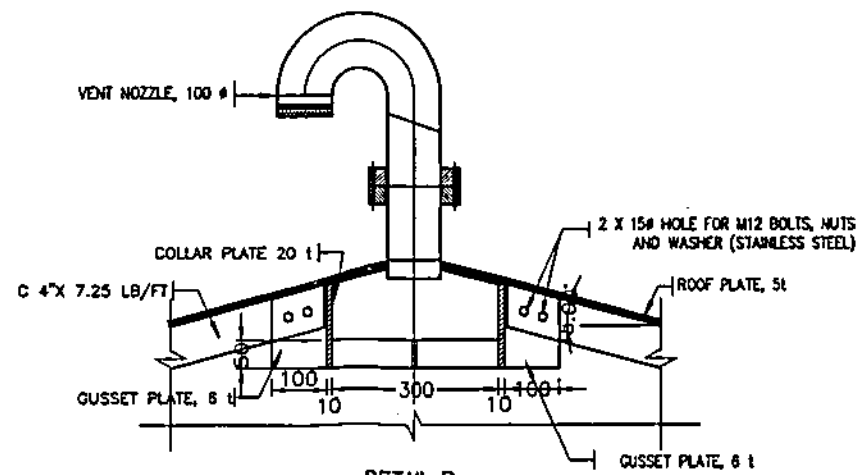

SECTION B



DETAIL B

NOTES :

1. ALL DIMENSIONS ARE IN MILLIMETERS UNLESS OTHERWISE SPECIFIED.
2. THE FUEL OIL STORAGE TANK SHALL BE CONSTRUCTED TO CONFORM WITH THE LATEST EDITION OF API 650 AND THE MINIMUM REQUIREMENTS SHOWN ON THIS DRAWING OR AS SPECIFIED IN THE TECHNICAL SPECIFICATIONS.
3. DETAILED DRAWINGS, IF NECESSARY SHALL BE SUBMITTED BY THE CONTRACTOR FOR NPC REVIEW/APPROVAL.
4. ALL WELDING WORKS SHALL CONFORM TO THE REQUIREMENTS OF THE SPECIFICATION AND API 650.

OWNER:		 <b>NATIONAL POWER CORPORATION</b> AGHAM ROAD, DILIMAN, QUEZON CITY	
PROJECT: SUPPLY, DELIVERY, INSTALLATION AND TEST OF 1235 KL AND 2566 KL FOOT FOR PATNANGUNAN DPP, PALAMAN DPP AND JOMALIG DPP INCLUDING CONSTRUCTION OF ASSOCIATED FACILITIES UNDER PACKAGE 1			
LOCATION: PATNANGUNAN, QUEZON PROVINCE			
TITLE:		<b>RAFTER DETAILS</b> <b>35 KL FUEL OIL STORAGE TANK</b>	
DESIGNED	BY	CHKD	DATE
DRAWN			
REVIEWED	PRINCIPAL ENGR./ARCHT.		
CHECKED			
ISSUED			
MECH			
SUBMITTED:		 <b>R. M. CALDARAN</b> Principal Engineer A	
RECOMMENDED:		 <b>A. A. RODRIGUEZ</b> Civil Engineer, ESE	
APPROVED:		 <b>G. B. MACPO, JR.</b> Chief Engineer, ESE	

DWG NO. PKG 105-BDM-17.009 SPEC NO. Lu2P20Z117006

REV.	DATE	NATURE OF REVISION	BY	CHKD	RECD.	APPR.	SCALE	AS SHOWN

BID DRAWING

**NOTES:**

1. ALL DIMENSIONS ARE IN MILLIMETERS UNLESS OTHERWISE SPECIFIED.
2. THE FUEL OIL STORAGE TANK SHALL BE CONSTRUCTED TO CONFORM WITH THE LATEST EDITION OF THE APPLICABLE STANDARDS AND THE MINIMUM REQUIREMENTS SHOWN ON THIS DRAWING AND AS SPECIFIED IN THE TECHNICAL SPECIFICATIONS.
3. DETAILED DRAWINGS IF NECESSARY SHALL BE SUBMITTED BY THE CONTRACTOR FOR NPG REVIEW AND APPROVAL.
4. NOZZLES FOR HEAT DETECTOR AND FOAM NOZZLE SHALL BE SUPPLIED WITH THREADED CAP AND BLIND FLANGE, RESPECTIVELY.
5. ALL WELDING WORKS SHALL CONFORM TO THE REQUIREMENTS OF THE SPECIFICATION AND API 650.
6. FLANGED REDUCER (80 # X 65#) SHALL BE PROVIDED EACH AT OUTLET, INLET AND FOAM NOZZLES.
7. TANK NOZZLES, CAGED LADDER, MANHOLE, ETC. SHALL BE INSTALLED BASED ON TANK ORIENTATION SHOWN ON RESPECTIVE PLANTS LAYOUT.

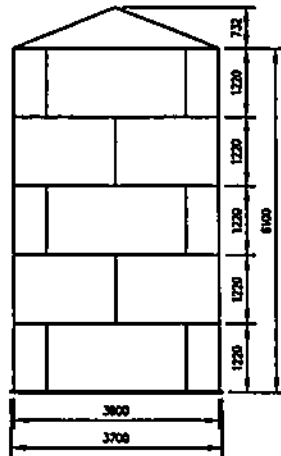

**SIDE ELEVATION**

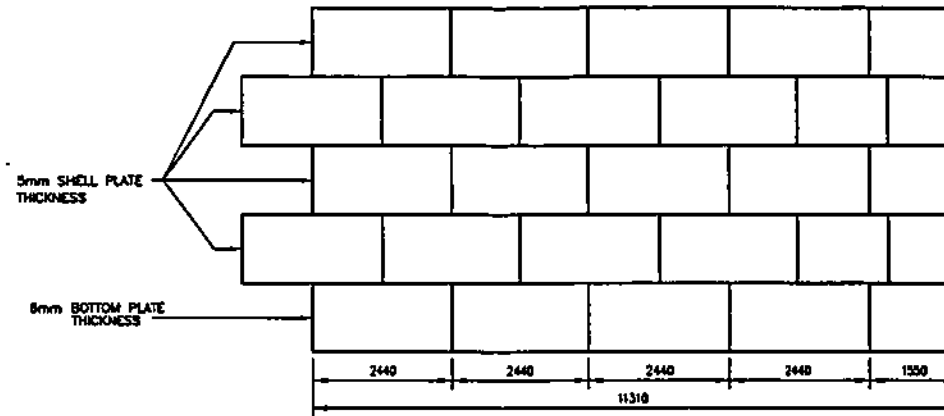

**SHELL PLATE ARRANGEMENT**

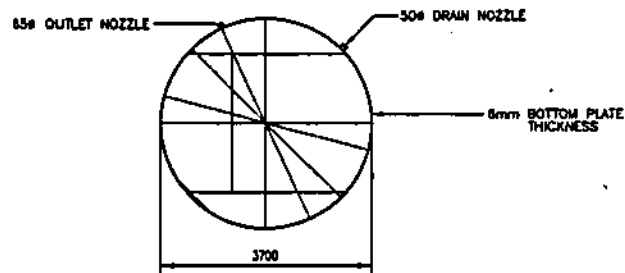

**BOTTOM PLATE ARRANGEMENT**

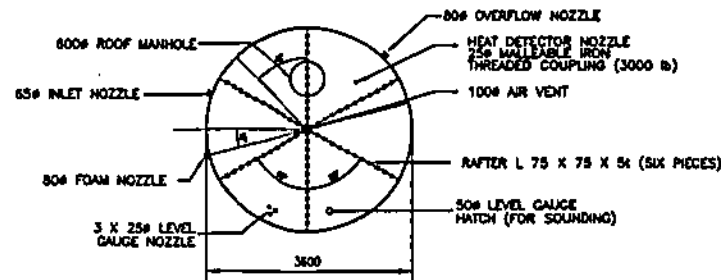

**ROOF PLATE ARRANGEMENT**

OWNER:		 <b>NATIONAL POWER CORPORATION</b> AGHAM ROAD, DILIMAN, QUEZON CITY	
PROJECT: SUPPLY, DELIVERY, INSTALLATION AND TEST OF 1438 KL AND 2300 KL FOST FOR PATRAMUNGAN DFP, PALANAN DFP, AND JOBAJAL DFP INCLUDING CONSTRUCTION OF ASSOCIATED FACILITIES UNDER PACKAGE 1			
LOCATION: SPUS PLANTS			
TITLE:		<b>PLATE ARRANGEMENT AND DETAILS</b> <b>60 KL FUEL OIL STORAGE TANK</b>	
DESIGNED	BY	CHKD	DATE
DRAWN	MAX		
REVIEWED	PRINCIPAL ENGR. / ARCHT.	RECOMMENDED	
CIVIL ARCHT.		APPROVED	
BLDG			
MACH	ITC		
G.O. NO. PKG160-BDM-17.001		SPEC. NO. LuzP20Z117989	
SCALE AS SHOWN		<b>BID DRAWING</b>	

REV.	DATE	REASON FOR REV. / CHG.	BY	CHKD.	PLCD.	APPD.

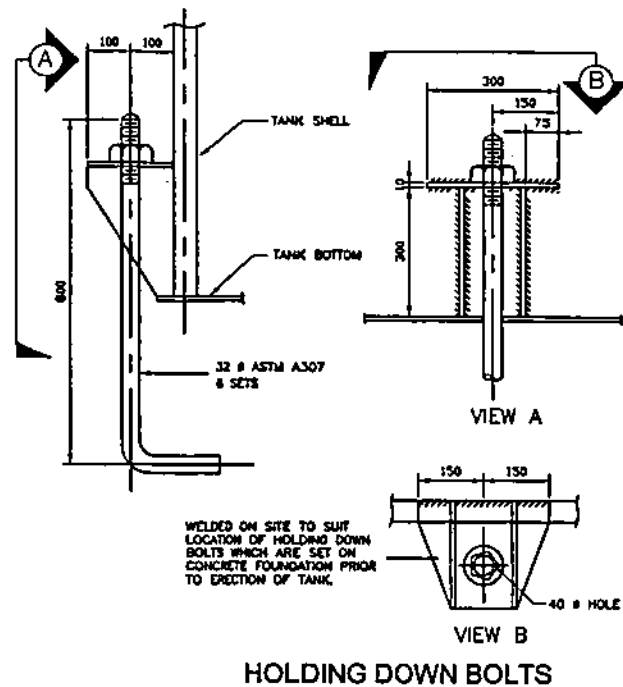
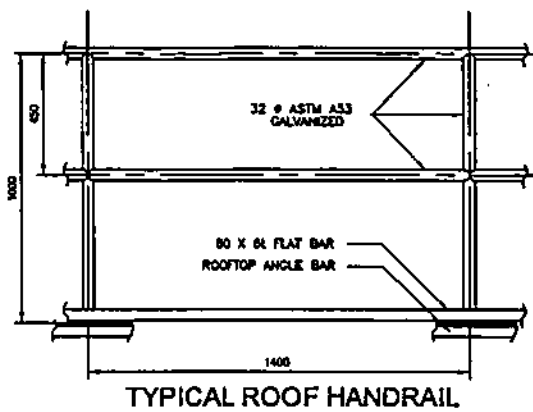
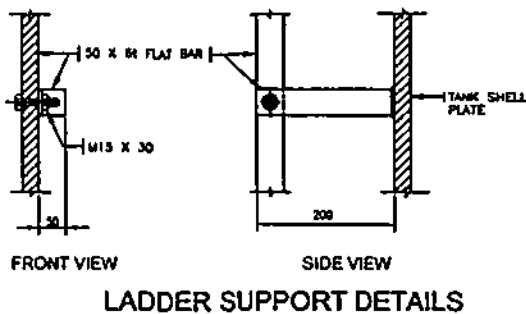
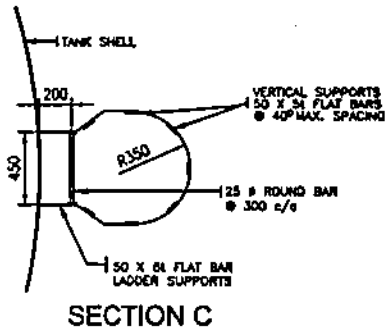
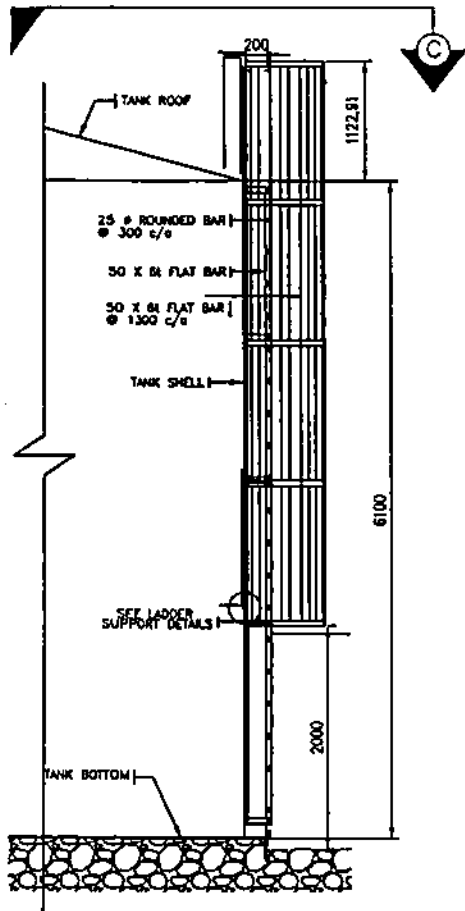

WELDED ON SITE TO SUIT LOCATION OF HOLDING DOWN BOLTS WHICH ARE SET ON CONCRETE FOUNDATION PRIOR TO ERECTION OF TANK.

**NOTES:**

1. ALL DIMENSIONS ARE IN ARE IN MILLIMETERS UNLESS OTHERWISE SPECIFIED.
2. THE FUEL OIL STORAGE TANK SHALL BE CONSTRUCTED TO CONFORM WITH THE LATEST EDITION OF THE APPLICABLE STANDARDS AND THE MINIMUM REQUIREMENTS SHOWN ON THIS DRAWING AND AS SPECIFIED IN THE TECHNICAL SPECIFICATIONS.
3. DETAILED DRAWINGS IF NECESSARY SHALL BE SUBMITTED BY THE CONTRACTOR FOR MPC REVIEW AND APPROVAL.
4. NOZZLE SIZES FOR HEAT DETECTOR, FOAM NOZZLE AND LEVEL GAUGE HATCH SHALL BE SUPPLIED WITH PLUGS/BLIND FLANGES.
5. ALL WELDING WORKS SHALL CONFORM TO THE REQUIREMENTS OF THE SPECIFICATION AND API 650.
6. NOZZLE FOR TANK SHALL BE INSTALLED BASED ON TANK ORIENTATION SHOWN ON RESPECTIVE PLANT'S LAYOUT

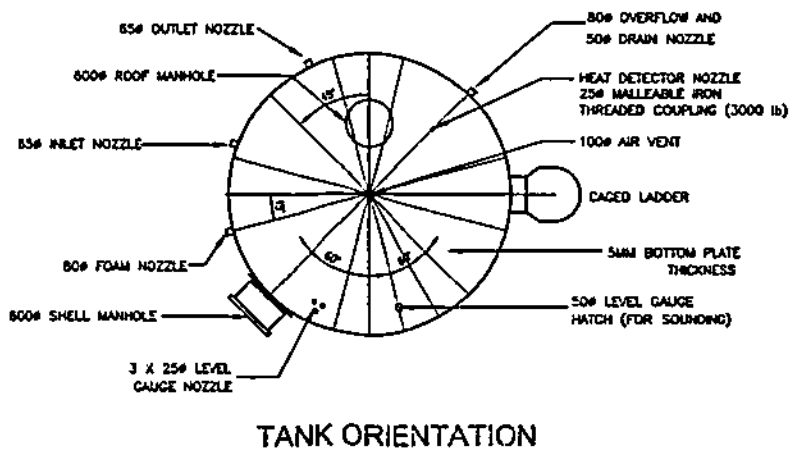
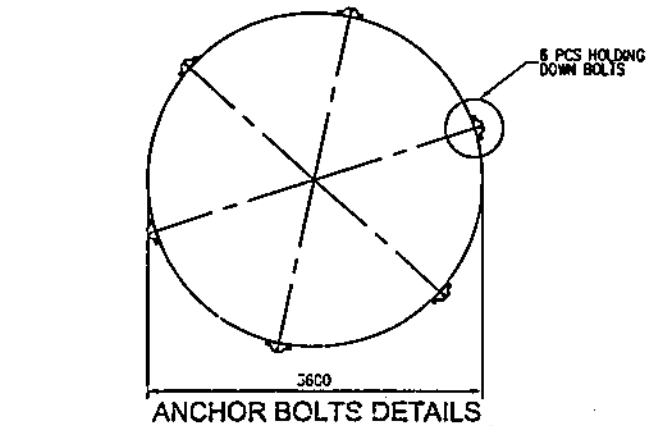

OWNER	<b>NATIONAL POWER CORPORATION</b> AGHAM ROAD, DELIMAN, QUEZON CITY		
PROJECT	SUPPLY, DELIVERY, INSTALLATION AND TEST OF 1200 KL AND 2000 KL POST FOR PATRAMANAN DDP, PALAMAN DDP, AND JONALIS DDP INCLUDING CONSTRUCTION OF ASSOCIATED FACILITIES UNDER PACKAGE 1		
LOCATION	BRIG PLANTS		
TITLE	<b>ORIENTATION AND DETAILS</b> <b>60 KL FUEL OIL STORAGE TANK</b>		
DESIGNED BY	CHKD	DATE	SUBMITTED
DRAWN	DATE		R. M. LAZAWAN
REVIEWED	PRINCIPAL ENGR. / ARCHT.		RECOMMENDED: A. N. RODRIGUEZ
DATE			APPROVED: G. B. MAGPOC JR.
MDL	JIC	✓	Dept Manager: T30

DWG. NO. PKG160-BDM-17.002      SPECS. NO. Lu2P20Z11792e

REV.	DATE	NUMBER OF REVISION	BY	CHKD	RECD	APPR

SCALE: AS SHOWN      **BID DRAWING**      REV. 0

**NOTES:**

1. ALL DIMENSIONS ARE IN MILLIMETERS UNLESS OTHERWISE SPECIFIED.
2. THE FUEL OIL STORAGE TANK SHALL BE CONSTRUCTED TO CONFORM WITH THE LATEST EDITION OF API 650 AND THE MINIMUM REQUIREMENTS SHOWN ON THIS DRAWING OR AS SPECIFIED IN THE TECHNICAL SPECIFICATIONS.
3. DETAILED DRAWINGS, IF NECESSARY SHALL BE SUBMITTED BY THE CONTRACTOR FOR NPC REVIEW/ APPROVAL.
4. ALL WELDING WORKS SHALL CONFORM TO THE REQUIREMENTS OF THE SPECIFICATION AND API 650.
5. INLET AND OVERFLOW NOZZLES SHALL BE SEPARATELY LOCATED DEPENDING ON THE ORIENTATION OF THE TANK SHOWN ON RESPECTIVE PLANT'S LAYOUT.
6. THE ERECTION PROCEDURE FOR DRAW OFF NOZZLE SHALL INCLUDE THE FOLLOWING STEP PER API 650:
  - A. A HOLE SHALL BE CUT IN THE BOTTOM PLATE OR A SUMP SHALL BE PLACED IN THE FOUNDATION BEFORE BOTTOM PLACEMENT;
  - B. A NEAT EXCAVATION SHALL BE MADE TO CONFORM TO THE SHAPE OF THE DRAWOFF SUMP, THE SUMP SHALL BE PUT IN PLACE, AND THE FOUNDATION SHALL BE COMPACTED AROUND THE SUMP AFTER PLACEMENT; AND
  - C. THE SUMP SHALL BE WELDED TO THE BOTTOM.

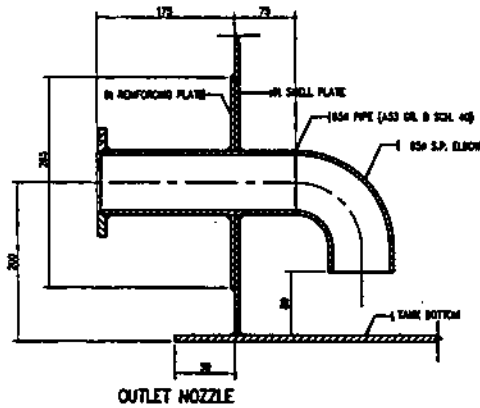

OUTLET NOZZLE

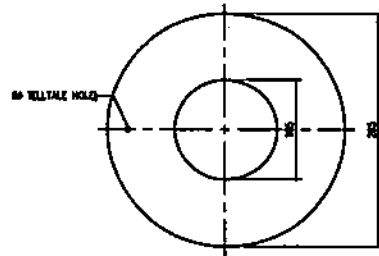

REINFORCING PLATE FOR 804 NOZZLE

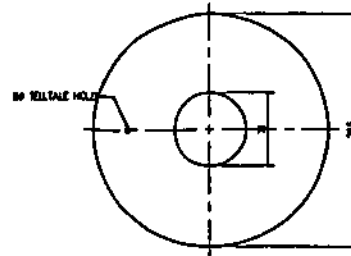

REINFORCING PLATE FOR 504 NOZZLE

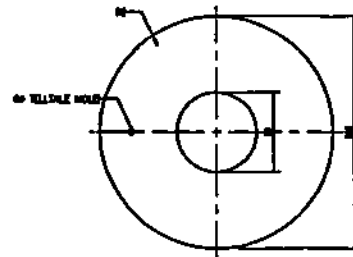

REINFORCING PLATE FOR 654 NOZZLE

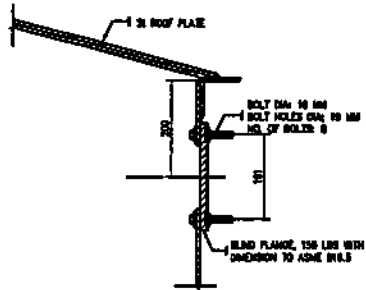

FOAM CHAMBER OPENING

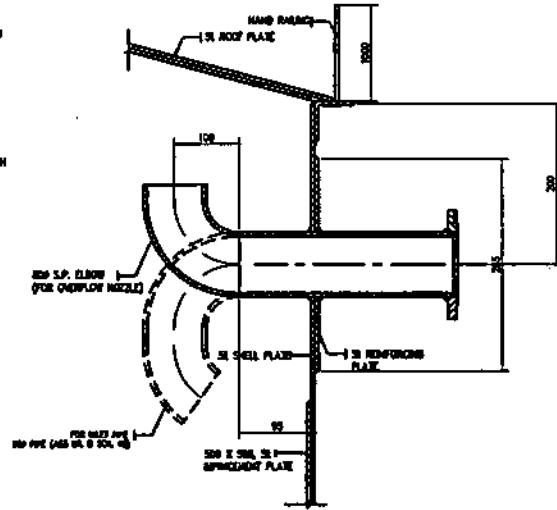

INLET/OVERFLOW NOZZLES (TYPICAL)

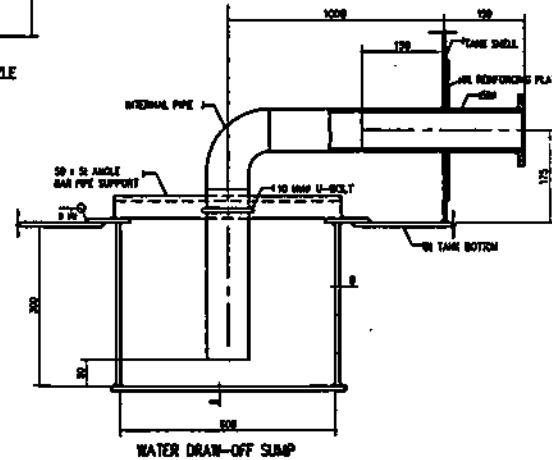

WATER DRAW-OFF SUMP

OWNER:				<b>NATIONAL POWER CORPORATION</b> AGHAM ROAD, DILIMAN, QUEZON CITY	
PROJECT: SUPPLY, DELIVERY, INSTALLATION AND TEST OF 1200 KL AND 2200 KL POND FOR PULVERIZERS DRY, FALANGAS DRY, AND FORMED DRY INCLUDING CONSTRUCTION OF ASSOCIATED FACILITIES UNDER PACKAGE 1					
LOCATION: SPMS PLANTS					
TITLE: <b>NOZZLE DETAILS</b> <b>60 KL FUEL OIL STORAGE TANK</b> (SHEET 1 OF 2)					
DESIGNED	BY	CHKD	DATE	SUBMITTED:	<i>R. A. CASAWAN</i>
DRAWN	<i>RAM</i>			RECOMMENDED:	<i>A. M. ROURIN</i>
REVIEWED	PRINCIPAL ENGR. / ARCHT.			APPROVED:	<i>C. S. BAGPOC JR.</i>
CHECKED				MECH	ITC

DRW NO: PKG160-BOM-17.000	ISSUE NO: LUCP20211753					
REV	DATE	NATURE OF REVISION	BY	CHKD	RECD	DATE
SCALE: AS SHOWN			BID DRAWING			REV: 1

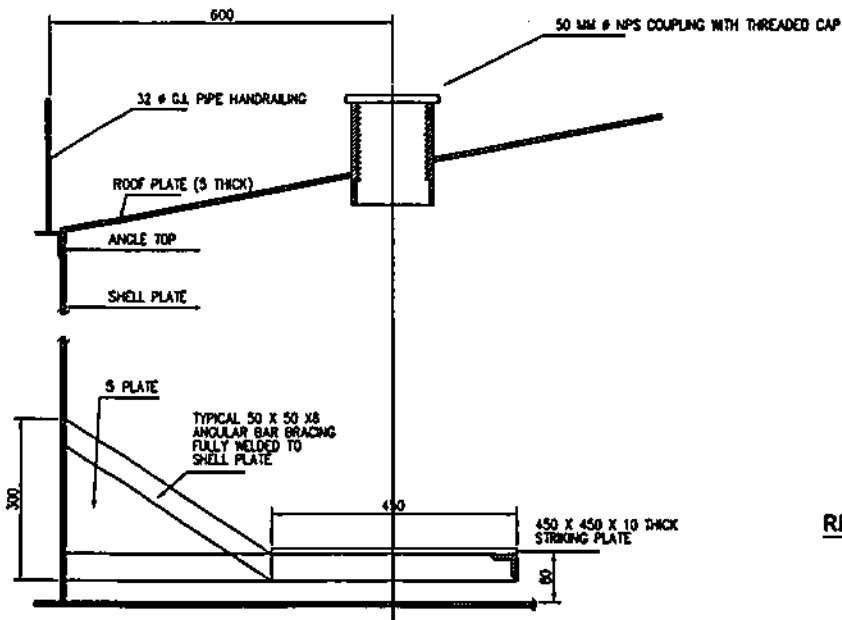

**Gauge Hatch Nozzle and Striking Plate**

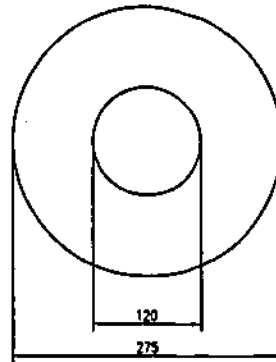

**REINFORCING PLATE FOR 100 Ø VENT NOZZLE**

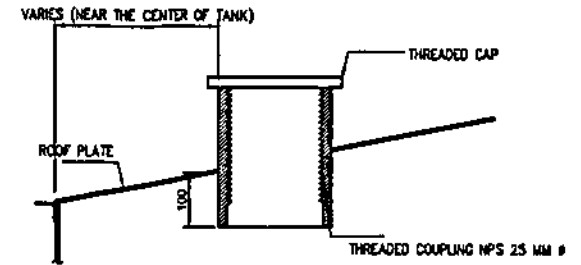

**HEAT DETECTOR NOZZLE**

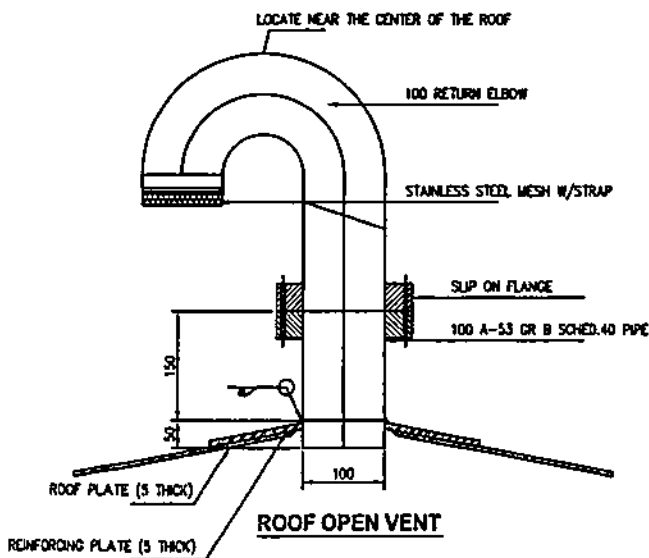

**ROOF OPEN VENT**

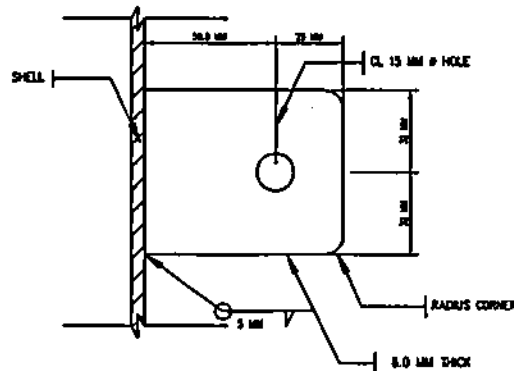

**GROUNDING LUG**

**NOTES FOR GROUNDING LUG:**

- LUG MATERIAL SHALL BE AUSTENITIC STAINLESS STEEL WHEN ATTACHED TO CARBON OR LOW ALLOY STEEL PARTS.
- TWO SETS INCLUDING 3 M LENGTH, 20 MM Ø COPPER GROUNDING ROD ARE REQUIRED FOR EACH TANK.

**NOTES:**

- ALL DIMENSIONS ARE IN MILLIMETERS UNLESS OTHERWISE SPECIFIED.
- THE FUEL OIL STORAGE TANK SHALL BE CONSTRUCTED TO CONFORM WITH THE LATEST EDITION OF API 650 AND THE MINIMUM REQUIREMENTS SHOWN ON THIS DRAWING OR AS SPECIFIED IN THE TECHNICAL SPECIFICATIONS.
- DETAILED DRAWINGS, IF NECESSARY SHALL BE SUBMITTED BY THE CONTRACTOR FOR NPC REVIEW/APPROVAL.
- ALL WELDING WORKS SHALL CONFORM TO THE REQUIREMENTS OF THE SPECIFICATION AND API 650.

OWNER:		 NATIONAL POWER CORPORATION AGHAM ROAD, DILIMAN, QUEZON CITY	
PROJECT: SUPPLY, DELIVERY, INSTALLATION AND TEST OF 1236 KL AND 2340 KL POTS FOR PATABANGAN DPP, PALASAN DPP, AND JONALIS DPP INCLUDING CONSTRUCTION OF ASSOCIATED FACILITIES UNDER PACKAGE 1			
LOCATION: SPUG PLANTS			
TITLE: NOZZLE ARRANGEMENT AND OTHER DETAILS 60 KL FUEL OIL STORAGE TANK (SHEET 2 OF 2)			
DESIGNED	BY	CHKD	DATE
DRAWN	MAN		
REVIEWED	PRINCIPAL ENGR./ARCHT.	RECOMMENDED:	<i>R. M. CAPSAWAN</i> Principal Engineer A
CIVIL/ARCHT			<i>A. N. RODRIGUEZ</i> Engr. Member, P.E.A.
ELEC.		APPROVED:	<i>G. B. MAGPOC JR.</i> Capt/Manager - DDD
MECH.	ITC		
DWG. NO. PKG160-BDM-17.004		SPEC. NO. LU2P20211795o	
SCALE: AS SHOWN	SID DRAWING		REV. 0

REV.	BY	CHKD.	RECD.	APPD.

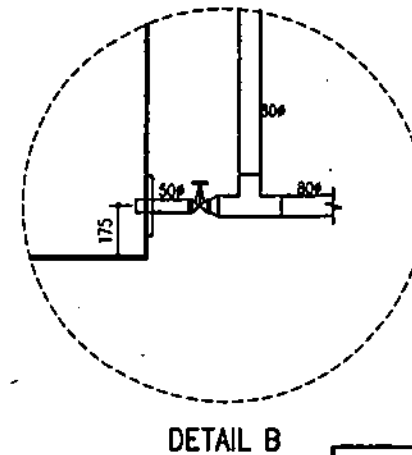
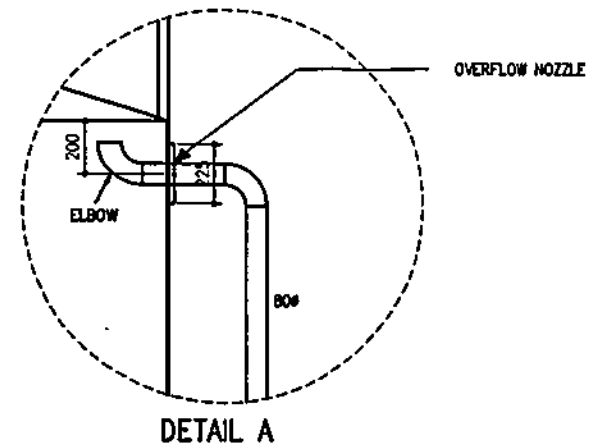
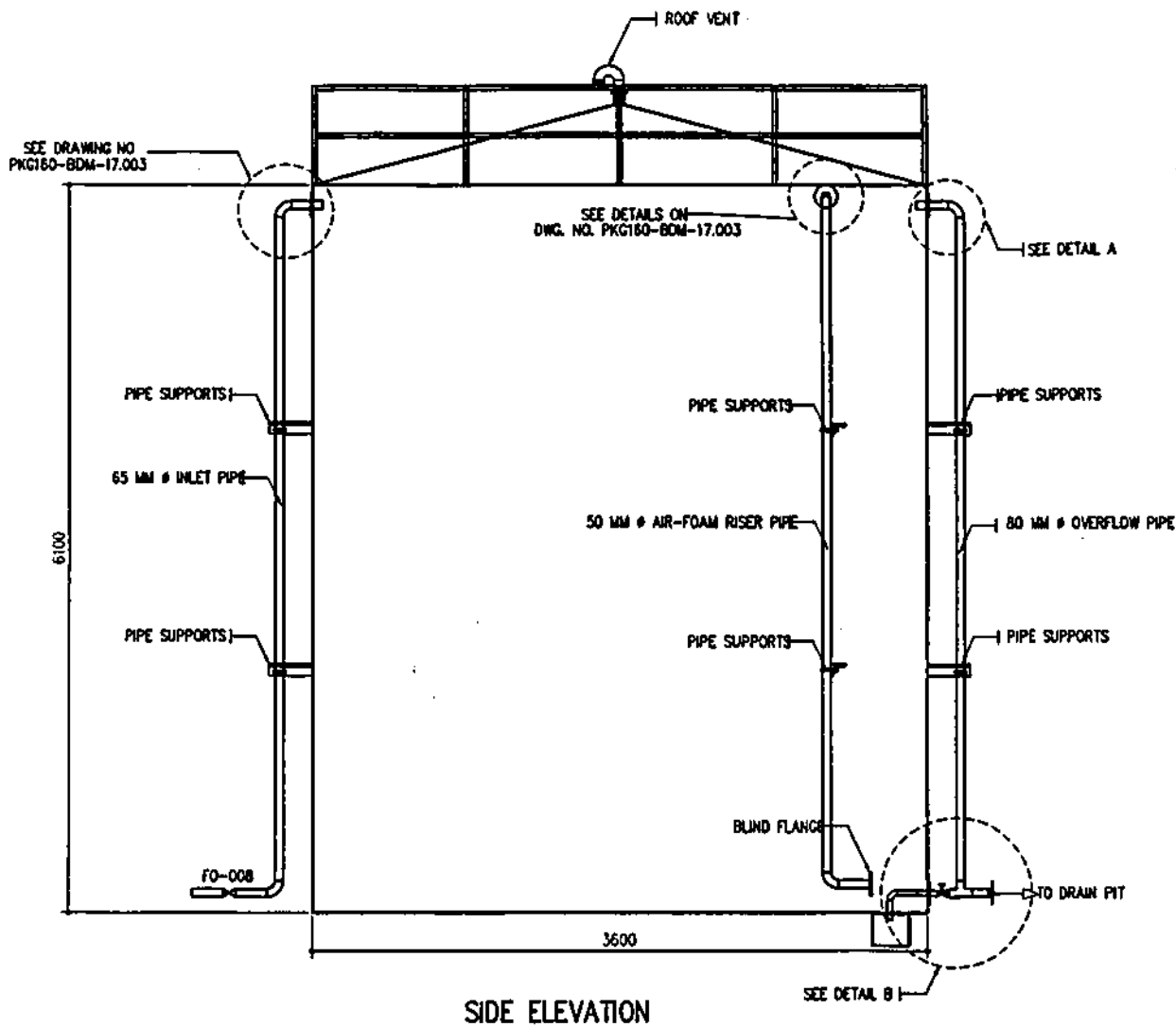

SIDE ELEVATION

DETAIL B

NOTES:

1. ALL DIMENSIONS ARE IN MILLIMETERS UNLESS OTHERWISE SPECIFIED.
2. THE FUEL OIL STORAGE TANK SHALL BE CONSTRUCTED TO CONFORM WITH THE LATEST EDITION OF API 650 AND THE MINIMUM REQUIREMENTS SHOWN ON THIS DRAWING OR AS SPECIFIED IN THE TECHNICAL SPECIFICATIONS.
3. DETAILED DRAWINGS, IF NECESSARY SHALL BE SUBMITTED BY THE CONTRACTOR FOR NPC REVIEW/APPROVAL.
4. ALL WELDING WORKS SHALL CONFORM TO THE REQUIREMENTS OF THE SPECIFICATION AND API 650.
5. PIPE SHALL CONFORM TO ASTM A 53 GR. B, SCHEDULE 40 AND SEAMLESS PIPE

OWNER		 <b>NATIONAL POWER CORPORATION</b> AGHAM ROAD, DALIMAN, QUEZON CITY	
PROJECT: SUPPLY, DELIVERY, INSTALLATION AND TEST OF 1120 KL AND 2080 KL POND FOR PATANUNGAN DFP, PALAMAN DFP, AND JORALIS DFP INCLUDING CONSTRUCTION OF ASSOCIATED FACILITIES UNDER PACKAGE 1 LOCATION: BPUS PLANTS			
TITLE		<b>TANK NOZZLES AND PIPE</b> 68 KL FUEL OIL STORAGE TANK	
DESIGNED	BY	CHKD	DATE
DRAWN REVISIONS CHECKED CLEC METAL	[Signature] [Signature] [Signature]	[Signature] [Signature]	[Signature] [Signature]
SUBMITTED		R. S. CALAWAN [Signature] AN. RODRIGUEZ [Signature] G. B. MAGPOC, JR. [Signature]	
DRAWING NO. PKG180-BDM-17.003		SPECS. NO. LuzP20Z11785	
SCALE: AS SHOWN		SID DRAWING	

REV.	DATE	NATURE OF REVISION	BY	CHKD.	INCD.	APP.

- NOTES:**
1. ALL DIMENSIONS ARE IN MILLIMETERS UNLESS OTHERWISE SPECIFIED.
  2. THE FUEL OIL STORAGE TANK SHALL BE CONSTRUCTED TO CONFORM WITH THE LATEST EDITION OF API 650 AND THE MINIMUM REQUIREMENTS SHOWN ON THIS DRAWING OR AS SPECIFIED IN THE TECHNICAL SPECIFICATIONS.
  3. DETAILED DRAWINGS, IF NECESSARY SHALL BE SUBMITTED BY THE CONTRACTOR FOR NPC REVIEW/APPROVAL.
  4. THE CONTRACTOR MAY PROPOSE DIFFERENT MANHOLE HINGE DETAILS, HENCE, SUBJECT TO NPC'S APPROVAL.
  5. ALL WELDING WORKS SHALL CONFORM TO THE REQUIREMENTS OF THE SPECIFICATION AND API 650.

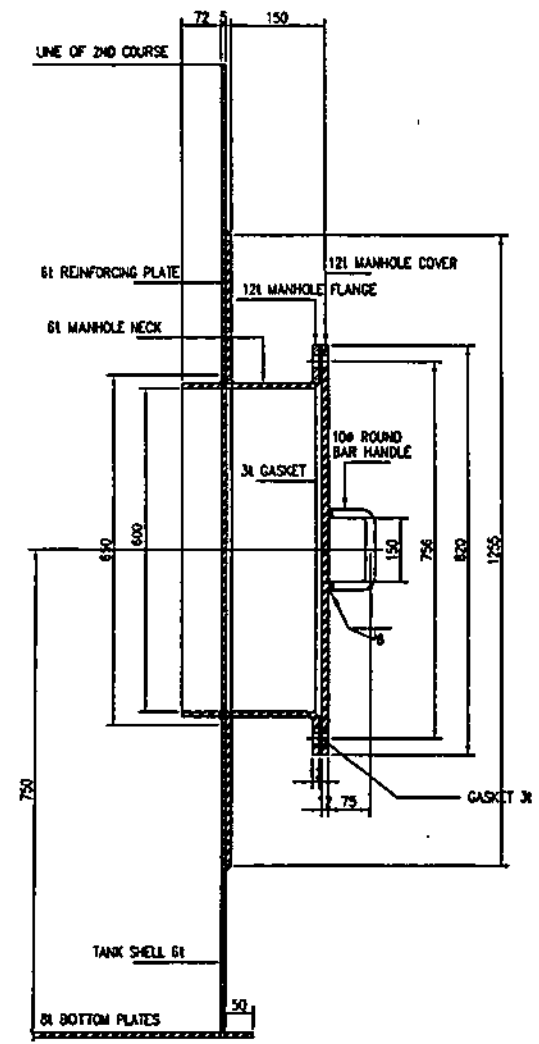

**SHELL MANHOLE SECTION**

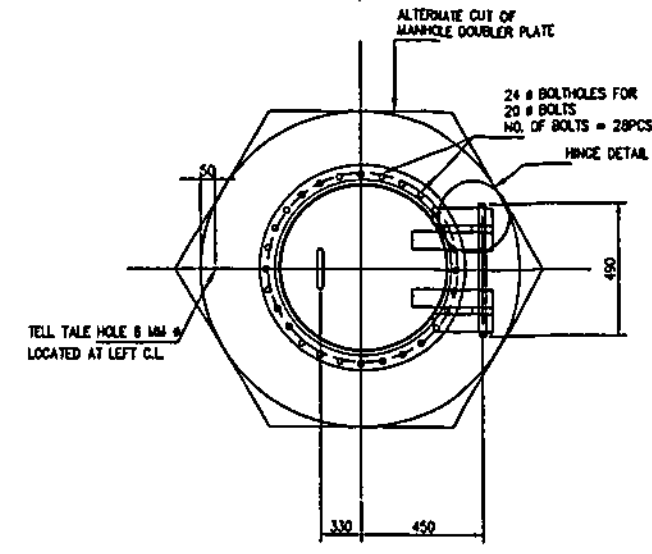

**SHELL MANHOLE PLAN**

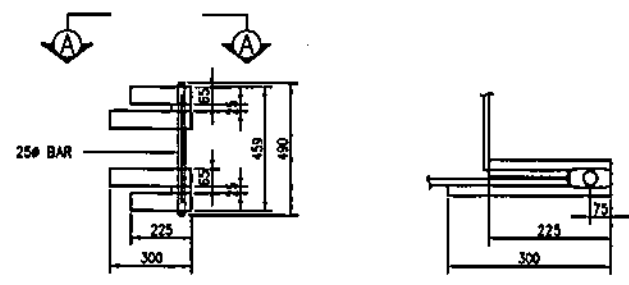

**HINGE DETAIL**

**SECTION A**

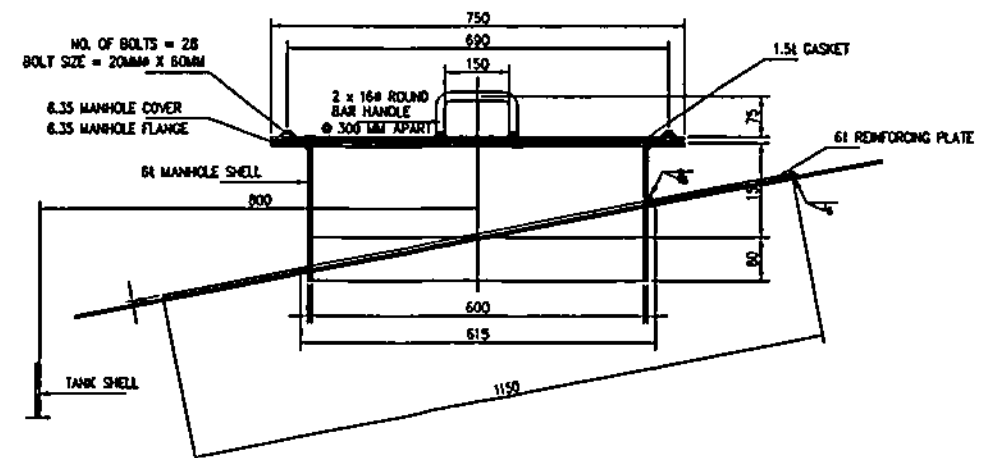

**ROOF MANHOLE SECTION**

OWNER		<b>NATIONAL POWER CORPORATION</b> AGHAM ROAD, DILIMAN, QUEZON CITY	
PROJECT: SUPPLY, DELIVERY, INSTALLATION AND TEST OF 1430 KL AND 2000 KL FOST FOR PATARANGKAR DPP, PALANGA DPP, AND JOGALEA DPP INCLUDING CONSTRUCTION OF ASSOCIATED FACILITIES UNDER PACKAGE 1			
LOCATION: SPHS PLANTS			
TITLE		<b>ROOF AND SHELL MANHOLE DETAILS</b> 60 KL FUEL OIL STORAGE TANK	
DESIGNED	BY	CHKD	DATE
DRAWN	MAN		
REVIEWED	PRINCIPAL ENGR./ARCHT.	RECOMMENDED	
CHECKED		APPROVED	
SEC			
DESIGN	JTC	4/8	
SUBMITTER: R. N. CADARWAN		RECOMMENDED: A. N. RODRIGUEZ	
APPROVED: G. B. MAGPOC JR.		DEPT. CHIEF	

DMC NO PKG160-BDM-17.006 SPEC. NO. L12P20Z11730

REV.	DATE	NATURE OF REVISION	BY	CHKD	REC'D	APTD.

SCALE: AS SHOWN **BID DRAWING**

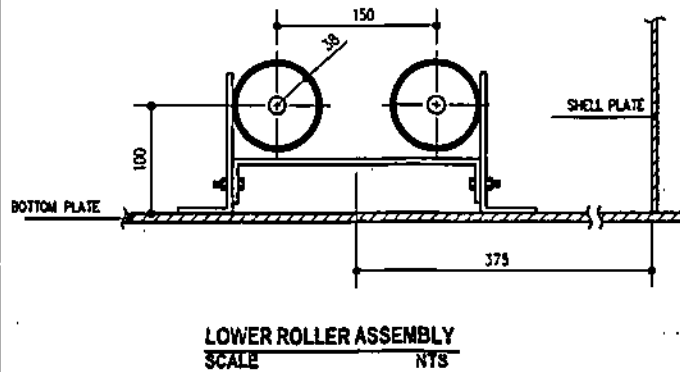
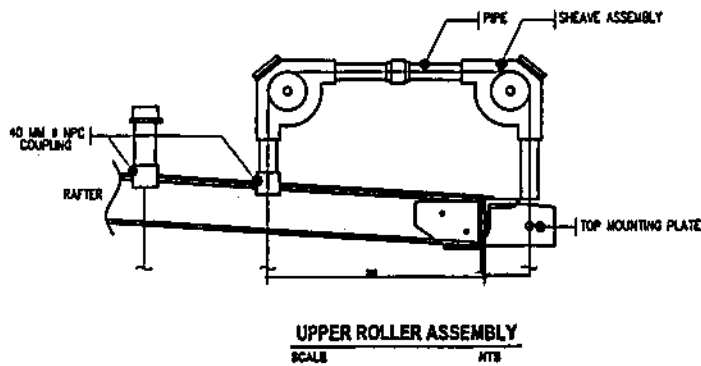
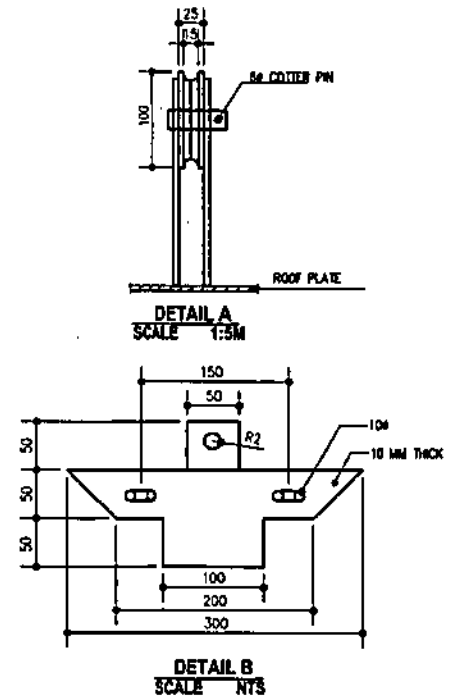
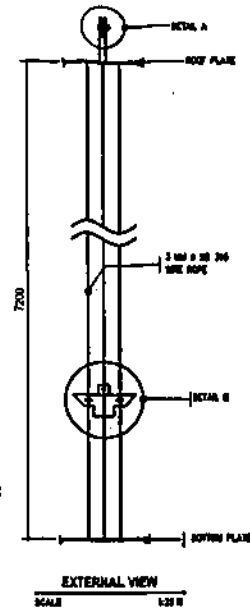
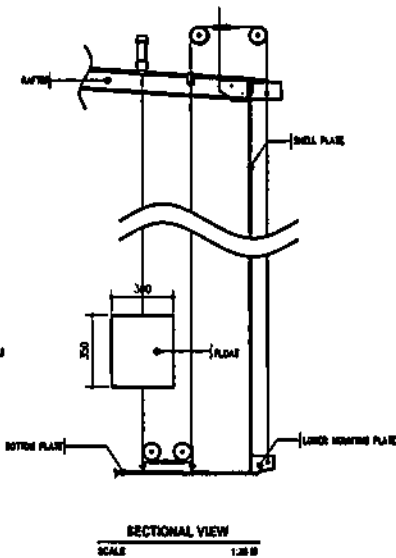
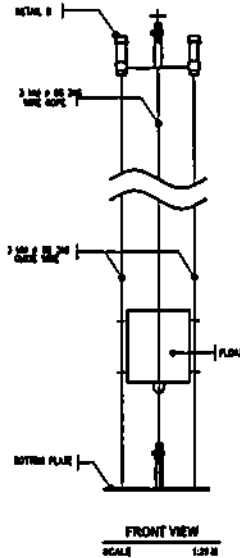
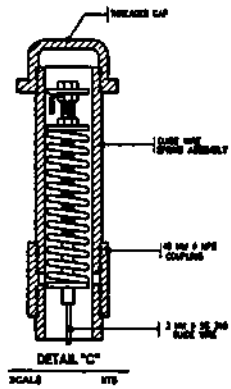

**NOTES:**

1. ALL DIMENSIONS ARE IN MILLIMETERS UNLESS OTHERWISE SPECIFIED.
2. THE FUEL OIL STORAGE TANK SHALL BE CONSTRUCTED TO CONFORM WITH THE LATEST EDITION OF API 650 AND THE MINIMUM REQUIREMENTS SHOWN ON THIS DRAWING OR AS SPECIFIED IN THE TECHNICAL SPECIFICATIONS.
3. DETAILED DRAWINGS, IF NECESSARY SHALL BE SUBMITTED BY THE CONTRACTOR FOR NPC REVIEW/APPROVAL.
4. ALL WELDING WORKS SHALL CONFORM TO THE REQUIREMENTS OF THE SPECIFICATION AND API 650.
5. CALIBRATION SCALES SHALL BE PAINTED ON THE TANK AND SHALL BE LARGE ENOUGH SO IT CAN EASILY BE VISIBLE FROM THE CONTROL ROOM / POWERHOUSE.
6. SIZE AND DIMENSIONS OF FLOAT AND BOARD TANK GAUGE ASSEMBLY MAY BE MODIFIED IN COORDINATION WITH THE DEVICE SUPPLIER.

OWNER:		 <b>NATIONAL POWER CORPORATION</b> AGHAM ROAD, DILIMAN, QUEZON CITY	
PROJECT: SUPPLY, DELIVERY, INSTALLATION AND TEST OF 1038 KL AND 2008 KL FOST FOR PATRAMUNGAN DFP, PALANAN DFP, AND JONALIS DFP INCLUDING CONSTRUCTION OF ASSOCIATED FACILITIES UNDER PACKAGE 1			
LOCATION: BRNO PLANTS			
TITLE: <b>LEVEL GAUGE INDICATOR DETAILS</b> 63 KL FUEL OIL STORAGE TANK			
DESIGNED	BY	CHKD	DATE
DRAWN	MAN		
REVIEWED	PRINCIPAL ENGR./ARCHT.	RECOMMENDED:	
CALCULATED			
ELEC.		APPROVED:	
MECH.	CC		
DWG. NO. PKG160-90M-17.007		SPEC. NO. Lu2P20Z1179SS	

KEY:	DATE:	NATURE OF REVISION:	BY:	CHKD:	REC'D:	DATE:	SCALE: NTS	SID DRAWING	REV. 2
------	-------	---------------------	-----	-------	--------	-------	------------	-------------	--------



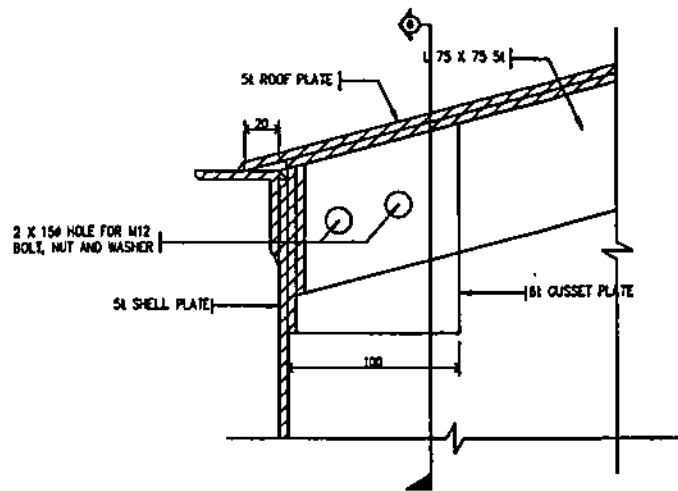

DETAIL A

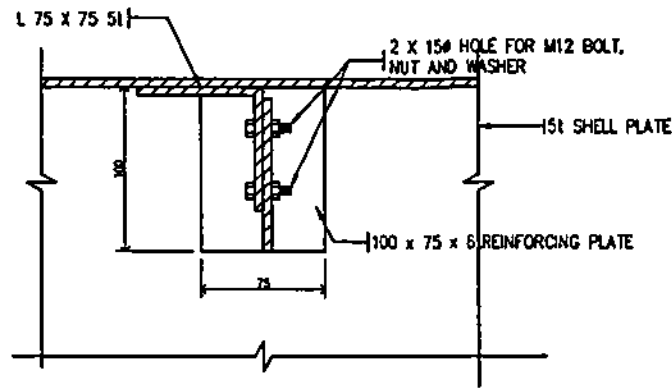

SECTION B

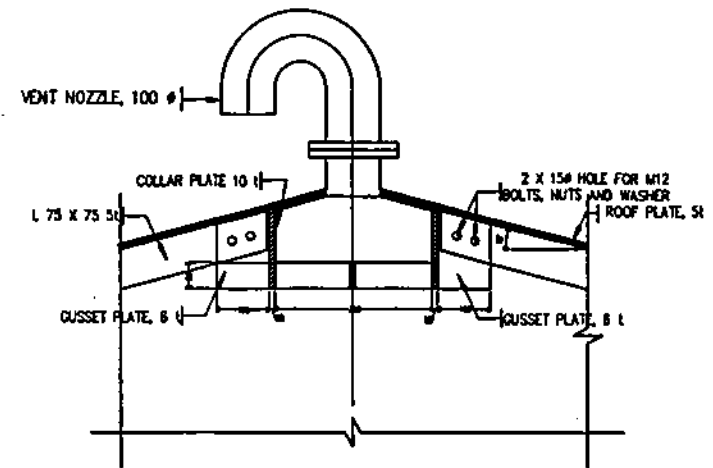

DETAIL B

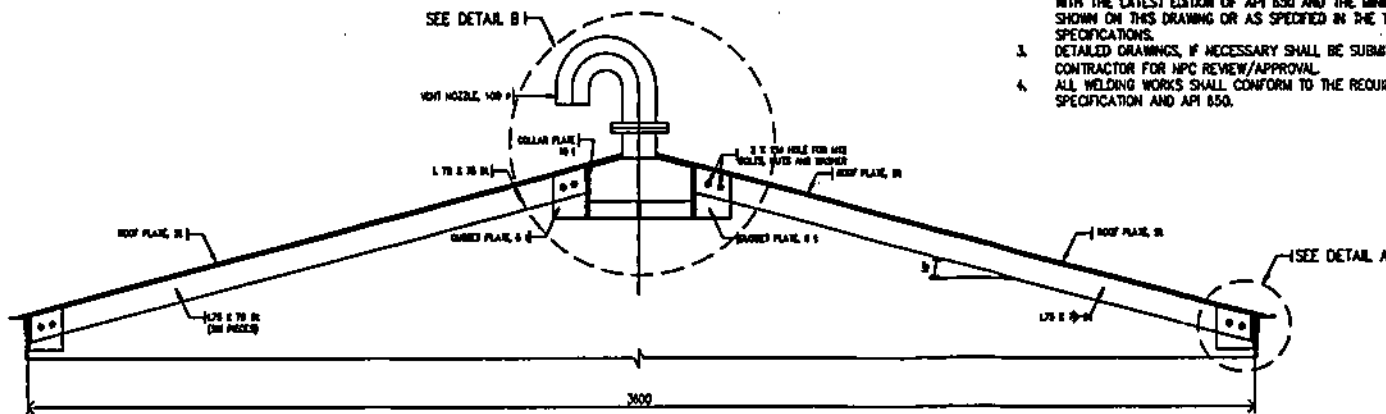

RAFTER DETAILS

NOTES:

1. ALL DIMENSIONS ARE IN MILLIMETERS UNLESS OTHERWISE SPECIFIED.
2. THE FUEL OIL STORAGE TANK SHALL BE CONSTRUCTED TO CONFORM WITH THE LATEST EDITION OF API 650 AND THE MINIMUM REQUIREMENTS SHOWN ON THIS DRAWING OR AS SPECIFIED BY THE TECHNICAL SPECIFICATIONS.
3. DETAILED DRAWINGS, IF NECESSARY SHALL BE SUBMITTED BY THE CONTRACTOR FOR NPC REVIEW/APPROVAL.
4. ALL WELDING WORKS SHALL CONFORM TO THE REQUIREMENTS OF THE SPECIFICATION AND API 650.

OWNER:		 <b>NATIONAL POWER CORPORATION</b> AGHAM ROAD, DILIMAN, QUEZON CITY	
PROJECT: SUPPLY, DELIVERY, INSTALLATION AND TEST OF 1135 KL AND 2280 KL POST FOR PATAWANGKAM DFP, PALANAN DFP, AND JORALJO DFP INCLUDING CONSTRUCTION OF ASSOCIATED FACILITIES UNDER PACKAGE 1			
LOCATION: SPUG PLANTS			
TITLE:		<b>RAFTER DETAILS</b> 60 KL FUEL OIL STORAGE TANK	
DESIGNED	BY	CHKD	DATE
DRAWN	MAN		
REVIEWED	PRINCIPAL ENGR./ARCHT.	RECOMMENDED	
OVERSIGHT		APPROVED	
BY			
DATE			

DWG NO PKG160-BDM-17.008 SPEC NO LUZP20211702

REV.	DATE	NATURE OF CHANGE	BY	CHKD	APPR	DATE

B:D DRAWING



**SECTION IX - BID DRAWINGS**

**EW - ELECTRICAL DRAWINGS**

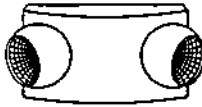

<b>DRAWING NO.</b>	<b>TITLE</b>
TypDPP-BDE-17.001	Pump Motor Control and Protection Panel Details
TypDPP-BDE-17.002	General Notes and Details of Lighting Fixtures
PatDPP-BDE-17.001	Lighting & Power Layout and Single Line Diagram (Patnanungan DPP)
PalDPP-BDE-17.001	Lighting & Power Layout and Single Line Diagram (Palanan DPP)
JomDPP-BDE-17.001	Lighting & Power Layout and Single Line Diagram (Jomalig DPP)

## GENERAL NOTES:

1. ALL WORKS SHALL BE DONE IN ACCORDANCE WITH THE LATEST PROVISIONS OF THE PHILIPPINE ELECTRICAL CODE, LAWS AND ORDINANCES OF THE LOCAL CODE ENFORCING AUTHORITIES.
2. METHOD OF WIRING SHALL BE IN uPVC WITH PROPER FITTINGS, DEVICES, BOXES AND SUPPORTS, WORK SHALL BE AS PER PLAN AND SPECIFICATIONS AS TO LOCATION, TYPE AND USE.
3. ALL SWITCHES AND CONVENIENCE OUTLETS SHALL BE FLUSH-MOUNTED 1.37 METERS AND 0.30 METER RESPECTIVELY ABOVE THE FINISHED FLOOR.
4. CONDUIT RUNS ARE INDICATIVE ONLY. THE ACTUAL RUNS SHALL BE DETERMINED IN THE FIELD.
5. WIRES, BOXES, ELECTRICAL AS WELL AS NON-ELECTRICAL MATERIALS NOT INCLUDED IN THE PLANS AND SPECIFICATION BUT NECESSARY TO COMPLETE THE JOB SHALL BE FURNISHED AND INSTALLED BY THE CONTRACTOR.
6. ALL ELECTRICAL MATERIALS TO BE USED IN THE INSTALLATION SHALL BE NEW, STANDARD AND APPROVED TYPE AS TO LOCATION, TYPES AND PURPOSE.
7. MINIMUM SIZE OF CONDUCTOR TO BE USED SHALL BE 3.5 mm<sup>2</sup> THHN/THWN-2 IN 20 mmØ uPVC, SCH.40 CONDUIT UNLESS OTHERWISE SPECIFIED IN THE PLAN.
8. ELECTRICAL WORKS SHALL BE DONE UNDER THE DIRECT SUPERVISION OF A DULY LICENSED ELECTRICAL ENGINEER.

	
<p>PORTABLE EMERGENCY LIGHTING FIXTURE, 2 x 2 WATTS LED WARM WHITE WITH BUILT-IN SEALED LEAD ACID BATTERY CHARGING TIME &lt; 20HRS; USAGE TIME &lt;= 4 HRS</p>	<p>1 x 9 WATTS COOL WHITE, CLASSIC GLOBE SHAPE, FROSTED FINISH, E27 BASE, COMPACT LED LAMP</p>

## DETAILS OF LIGHTING FIXTURES

 <b>NATIONAL POWER CORPORATION</b> AGHAM ROAD, DILIMAN, QUEZON CITY																													
PROJECT: SUPPLY, DELIVERY, INSTALLATION AND TEST OF 1 x 36 HL AND 2 x 48 HL FORT FOR PATNANUNGAN DPP, PALAMAN DPP AND JOMALIS DPP INCLUDING CONSTRUCTION OF ASSOCIATED FACILITIES UNDER PACKAGE 1 LOCATION: VARIOUS AREAS IN QUEZON																													
<b>GENERAL NOTES AND DETAILS OF LIGHTING FIXTURES</b>																													
<table border="1"> <thead> <tr> <th></th> <th>BY</th> <th>CHKD</th> <th>DATE</th> </tr> </thead> <tbody> <tr> <td>DESIGNED</td> <td>JLD</td> <td></td> <td></td> </tr> <tr> <td>DRAWN</td> <td>JLD</td> <td></td> <td></td> </tr> <tr> <td>REVIEWED</td> <td>PRINCIPAL ENGR./ARCHT.</td> <td></td> <td></td> </tr> <tr> <td>CIVIL/ARCHT</td> <td></td> <td></td> <td></td> </tr> <tr> <td>ELEC</td> <td></td> <td></td> <td></td> </tr> <tr> <td>MECH</td> <td></td> <td></td> <td></td> </tr> </tbody> </table>		BY	CHKD	DATE	DESIGNED	JLD			DRAWN	JLD			REVIEWED	PRINCIPAL ENGR./ARCHT.			CIVIL/ARCHT				ELEC				MECH				SUBMITTED:  RECOMMENDED: <b>A. S. CONDELARIA III</b> Manager, E&C APPROVED: <b>G. B. MAGPOC JR.</b> Manager, DPP
	BY	CHKD	DATE																										
DESIGNED	JLD																												
DRAWN	JLD																												
REVIEWED	PRINCIPAL ENGR./ARCHT.																												
CIVIL/ARCHT																													
ELEC																													
MECH																													
DWG. NO. TypDPP-BDE-17.002      SPEC. NO. LuzP20Z1179Sg																													
SCALE: N.T.S. <b>BID DRAWING</b> REV. 0																													

REV.	DATE	NATURE OF REVISION	BY	CHKD.	RECD.	APPD.

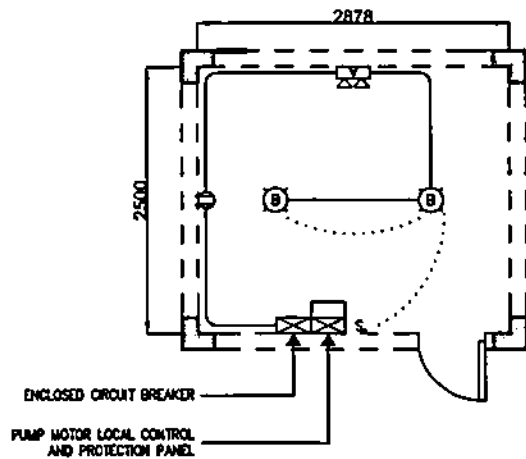

**LIGHTING & POWER LAYOUT**  
SCALE 1:50

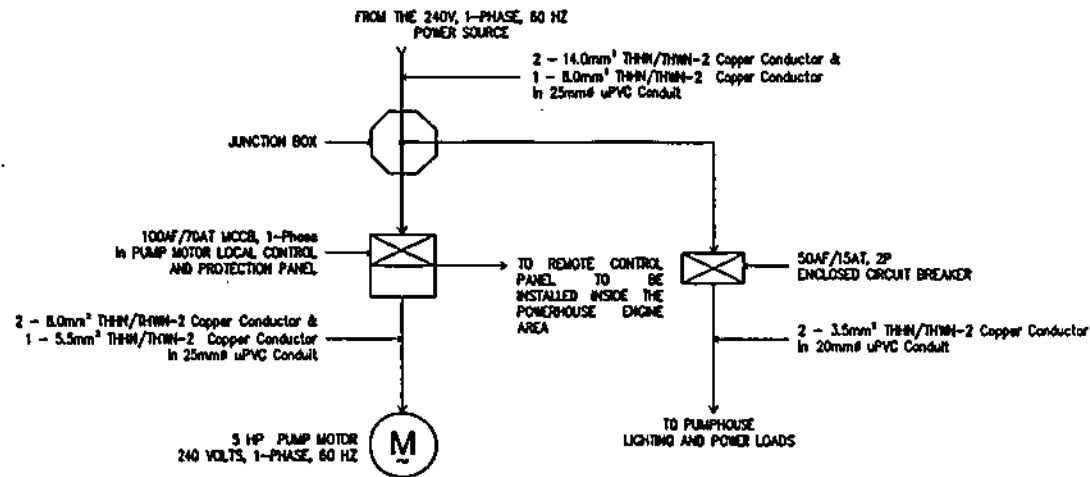

**SINGLE LINE DIAGRAM**

**LEGEND:**

- FIXTURE TYPE A
- FIXTURE TYPE B
- SINGLE POLE WALL SWITCH
- 200 VA DUPLEX CONVENIENCE OUTLET
- CONTROL CIRCUIT
- CIRCUIT RUNNING ON CEILING
- ENCLOSED CIRCUIT BREAKER
- PUMP MOTOR LOCAL CONTROL AND PROTECTION PANEL

**NOTES:**

1. THE CONTRACTOR SHALL SUPPLY, INSTALL, AND TEST A NEW 5 HP PUMP MOTOR.
2. THE CONTRACTOR SHALL PROVIDE LOCAL CONTROL & PROTECTION PANEL AND REMOTE PANEL, COMPLETE WITH NECESSARY MONITORING PARAMETERS, RELAYS, CONTACTORS AND OVERCURRENT PROTECTIVE DEVICES FOR THE NEW PUMP MOTOR.
3. THE CONTRACTOR SHALL SUPPLY, INSTALL, AND TEST A NEW LIGHTING FIXTURE, EMERGENCY LIGHTING AND POWER OUTLET.
4. THE PUMP MOTOR AND ITS PANELS SHALL BE PROPERLY GROUNDED.
5. POWER SUPPLY SHALL BE TAKEN FROM THE PLANT EXISTING 240 VOLTS, 1-PHASE, 60 HERTZ SYSTEM OR AS PER END-USER DIRECTION.
6. ALL EQUIPMENT/STRUCTURES DRAWN IN BROKEN LINES ARE EXISTING. ALL OTHERS ARE INCLUDED IN THE CONTRACT.

OWNER		<b>NATIONAL POWER CORPORATION</b> AGHAM ROAD, DILIMAN, QUEZON CITY	
PROJECT: SUPPLY, DELIVERY, INSTALLATION AND TEST OF 1 X 35 KL AND 2 X 80 KL FOST FOR PATNABANGKAW DPP, PALAWAN DPP AND ADHALL DPP INCLUDING CONSTRUCTION OF ASSOCIATED FACILITIES UNDER PACKAGE 1			
LOCATION: PALAWAN, ISABELA			
TITLE <b>LIGHTING &amp; POWER LAYOUT AND SINGLE LINE DIAGRAM</b>			
DESIGNED	BY	CHKD	DATE
DRAWN	FLD		
REVIEWED	PRINCIPAL ENGR./ARCHT.	RECOMMENDED	 <b>E. S. LAGULA</b> PROJECT ENGINEER A
CIVIL/ARCHT			<b>A. S. ORDELARIA III</b> PROJECT ENGINEER
ELEC.			<b>G. B. MAGPOC JR.</b> MANAGER, PDS
MECH.			
DWG NO. PalDPP-BDE-17.001		SPECS NO. LuzP20Z1179Sg	
REV.	DATE	NATURE OF REVISION	BY
SCALE AS SHOWN		BID DRAWING	
		REV. 0	

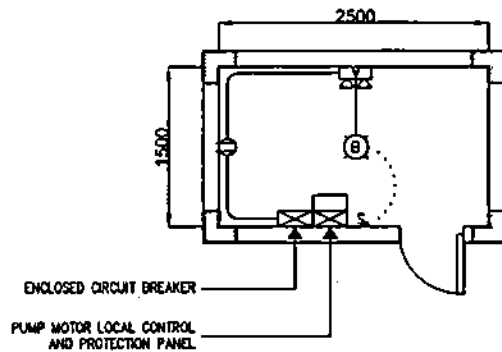

### LIGHTING & POWER LAYOUT

SCALE 1:50

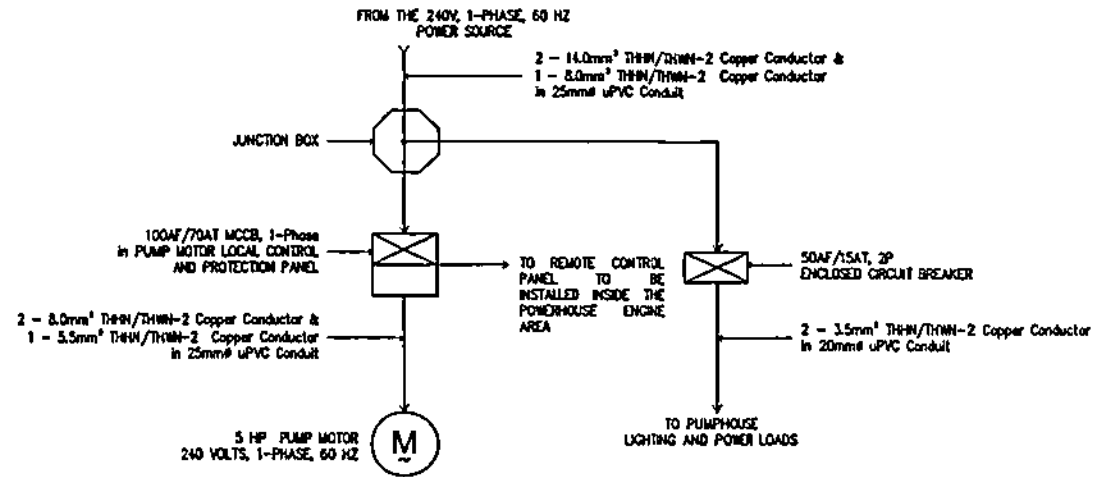

### SINGLE LINE DIAGRAM

#### LEGEND:

- FIXTURE TYPE A
- FIXTURE TYPE B
- SINGLE POLE WALL SWITCH
- 200 VA DUPLEX CONVENIENCE OUTLET
- CONTROL CIRCUIT
- CIRCUIT RUNNING ON CEILING
- ENCLOSED CIRCUIT BREAKER
- PUMP MOTOR LOCAL CONTROL AND PROTECTION PANEL

#### NOTES:

1. THE CONTRACTOR SHALL SUPPLY, INSTALL, AND TEST A NEW 5 HP PUMP MOTOR.
2. THE CONTRACTOR SHALL PROVIDE LOCAL CONTROL & PROTECTION PANEL AND REMOTE PANEL, COMPLETE WITH NECESSARY MONITORING PARAMETERS, RELAYS, CONTACTORS AND OVERCURRENT PROTECTIVE DEVICES FOR THE NEW PUMP MOTOR.
3. THE CONTRACTOR SHALL SUPPLY, INSTALL, AND TEST A NEW LIGHTING FIXTURE, EMERGENCY LIGHTING AND POWER OUTLET.
4. THE PUMP MOTOR AND ITS PANELS SHALL BE PROPERLY GROUNDED.
5. POWER SUPPLY SHALL BE TAKEN FROM THE PLANT EXISTING 240 VOLTS, 1-PHASE, 60 HERTZ SYSTEM OR AS PER END-USER PERSONNEL'S DIRECTION.

OWNER:  NATIONAL POWER CORPORATION AGHAM ROAD, DILIMAN, QUEZON CITY	
PROJECT: SUPPLY, DELIVERY, INSTALLATION AND TEST OF 1 X 38 KL AND 3 X 80 KL POST FOR PATNANGALAN DWP, PALAMAN DWP AND JOHLES DWP INCLUDING CONSTRUCTION OF ASSOCIATED FACILITIES UNDER PACKAGE 1	
LOCATION: PATNANGALAN, QUEZON	
TITLE: <b>LIGHTING &amp; POWER LAYOUT AND SINGLE LINE DIAGRAM</b>	
DESIGNED: RLB	DATE: _____
DRAWN: RLB	SUBMITTED:
REVIEWED: PRINCIPAL ENGINEER	RECOMMENDED:
CONTRACTOR: _____	APPROVED:
ELEC. _____	MECH. _____
DWR NO. PalOPP-BDE-17.001	
SPECS NO. LuzP20Z1179S <sup>e</sup>	
REV. DATE NATURE OF REVISION BY CHKD. RECD. APPD.	SCALE AS SHOWN BID DRAWING REV. 0

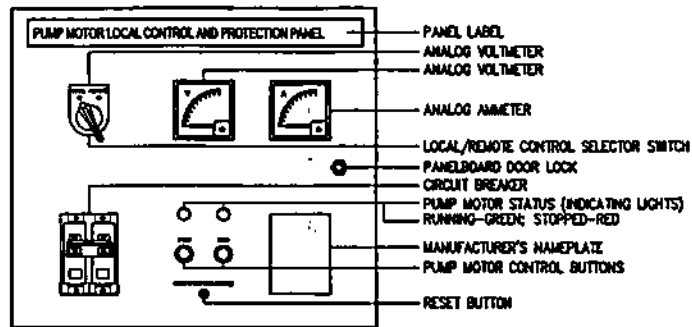

**PUMP MOTOR LOCAL CONTROL AND PROTECTION PANEL (LCPP)**

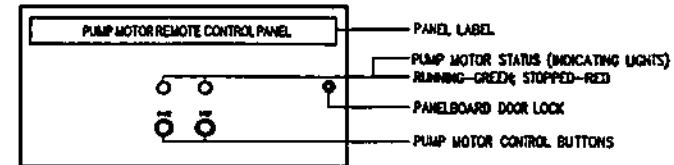

**PUMP MOTOR REMOTE CONTROL PANEL (RCP)**

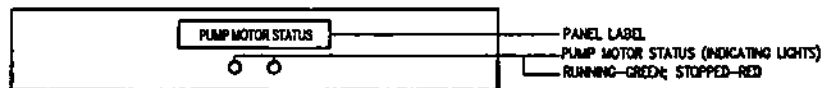

**PUMP MOTOR STATUS MONITORING PANEL**

**NOTES:**

1. ALL DIMENSIONS INDICATED ARE IN MILLIMETERS UNLESS OTHERWISE SPECIFIED.
2. PUMP MOTOR CONTROL, PROTECTION AND/OR MONITORING PANELS SHALL BE COLORED RAL 7032 AND ITS STEEL SHEET THICKNESS SHALL BE AT LEAST 2.0 MILLIMETERS.
3. THE CONTRACTOR SHALL DESIGN THE CABLE ENTRY FOR ALL THE POWER, CONTROL AND INSTRUMENTATION TO BE USED.
4. THE PUMP MOTOR MONITORING PANEL SHALL BE INSTALLED INSIDE THE CONTROL ROOM.
5. REMOTE CONTROL PANEL (RCP) SHALL BE INSTALLED AT THE POWER HOUSE ENGINE AREA.
6. THE CONTRACTOR SHALL PROVIDE THE BROCHURES/ CATALOGUES OF THE PUMP MOTOR CONTROL AND MONITORING PANELS INCLUDING COMPONENTS FOR METERING, PROTECTION, CONTROL AND MONITORING PURPOSES FOR APPROVAL OF NPC.

OWNER		 <b>NATIONAL POWER CORPORATION</b> AGHAM ROAD, DILIMAN, QUEZON CITY	
PROJECT: SUPPLY, DELIVERY, INSTALLATION AND TEST OF 1 X 36 RL AND 2 X 90 XL POSTS FOR PATASINGAN DPP, PALAMAN DPP AND JOMALO DPP INCLUDING CONSTRUCTION OF ASSOCIATED FACILITIES UNDER PACKAGE 1			
LOCATION: VARIOUS AREAS IN QUEZON			
TITLE: <b>PUMP MOTOR CONTROL AND PROTECTION PANEL DETAILS</b>			
DESIGNED	BY	CHKD	DATE
DRWNG	ILD		
REVIEWED	PRINCIPAL ENGR. / ARCHT.	RECOMMENDED	
CHKD/ARCHT			
ELEC.		APPROVED	
MECH.			
DWG. NO. TypDPP-BDE-17.001		SPEC. NO. LuzP20Z1179Se	
SCALE: N.T.S.		BID DRAWING	
REV. 0		REV. 0	

REV.	DATE	NATURE OF REVISION	BY	CHKD.	RECD.	APPD.

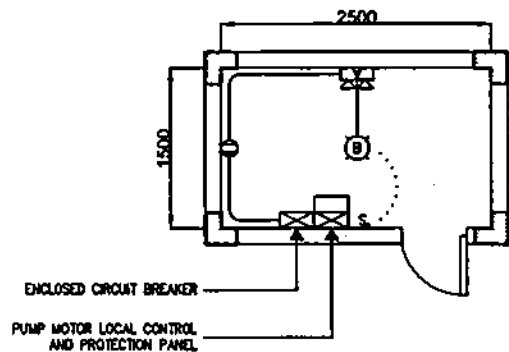



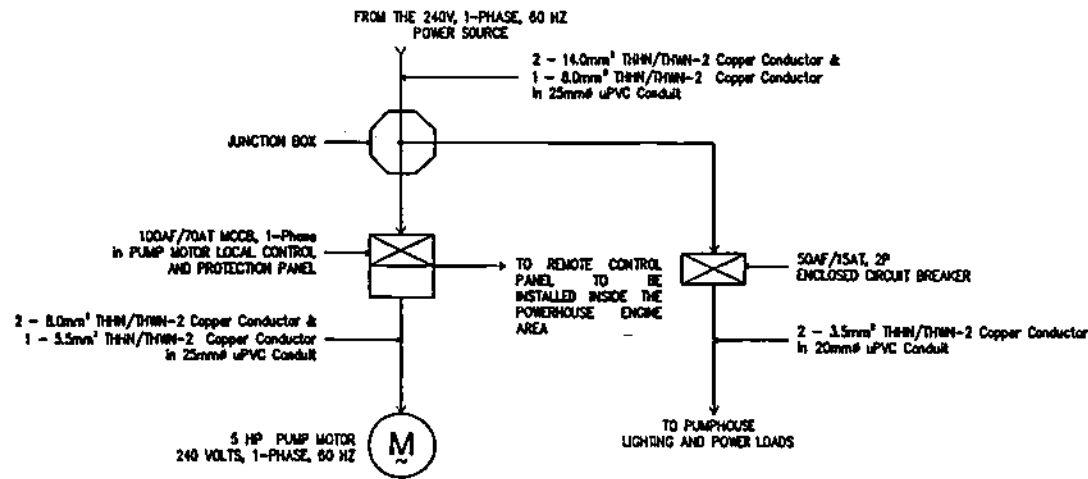





**LIGHTING & POWER LAYOUT**  
SCALE 1:50



**SINGLE LINE DIAGRAM**

**LEGEND:**

-  - FIXTURE TYPE A
-  - FIXTURE TYPE B
-  - SINGLE POLE WALL SWITCH
-  - 200 VA DUPLEX CONVENIENCE OUTLET
-  - CONTROL CIRCUIT
-  - CIRCUIT RUNNING ON CEILING
-  - ENCLOSED CIRCUIT BREAKER
-  - PUMP MOTOR LOCAL CONTROL AND PROTECTION PANEL

**NOTES:**

1. THE CONTRACTOR SHALL SUPPLY, INSTALL, AND TEST A NEW 5 HP PUMP MOTOR.
2. THE CONTRACTOR SHALL PROVIDE LOCAL CONTROL & PROTECTION PANEL AND REMOTE PANEL, COMPLETE WITH NECESSARY MONITORING PARAMETERS, RELAYS, CONTACTORS AND OVERCURRENT PROTECTIVE DEVICES FOR THE NEW PUMP MOTOR.
3. THE CONTRACTOR SHALL SUPPLY, INSTALL, AND TEST A NEW LIGHTING FIXTURE, EMERGENCY LIGHTING AND POWER OUTLET.
4. THE PUMP MOTOR AND ITS PANELS SHALL BE PROPERLY GROUNDED.
5. POWER SUPPLY SHALL BE TAKEN FROM THE PLANT EXISTING 240 VOLTS, 1-PHASE, 60 HERTZ SYSTEM OR AS PER END-USER PERSONNEL'S DIRECTION.

OWNER:  NATIONAL POWER CORPORATION AGHAM ROAD, DILIMAN, QUEZON CITY									
PROJECT: SUPPLY, DELIVERY, INSTALLATION AND TEST OF 1 X 38 KL AND 2 X 60 KL FOOT FOR BATHAMBINGAN DPP, PALAMAY DPP AND JOCALIS DPP INCLUDING CONSTRUCTION OF ASSOCIATED FACILITIES UNDER PACKAGE 1									
LOCATION: JOMALAG, QUEZON									
TITLE: <b>LIGHTING &amp; POWER LAYOUT AND SINGLE LINE DIAGRAM</b>									
DESIGNED: <input type="checkbox"/> JLD	DATE: <input type="checkbox"/>								
DRAWN: <input type="checkbox"/> JLD	DATE: <input type="checkbox"/>								
REVIEWED: <input type="checkbox"/> PRINCIPAL ENGR./ARCHT.	RECOMMENDED: <b>A. S. CANDELARIA III</b> Principal Engr.								
CHECKED: <input type="checkbox"/>	APPROVED: <b>G. E. MAGPOC JR.</b> Manager, E&C								
ELEC: <input type="checkbox"/>									
MECH: <input type="checkbox"/>									
DWG. NO. JomDPP-BDE-17.001									
SPEC. NO. LuzP20Z1179Sg									
REV.	DATE	NATURE OF REVISION	BY	CHECKED	RECORD	APPROVED	SCALE AS SHOWN	BID DRAWING	REV. 0